



Bruker BioSpin

NMR Magnet System •

UltraShield Magnets (English Version)
User Manual

Version 006

The information in this manual may be altered without notice.

BRUKER BIOSPIN AG accepts no responsibility for actions taken as a result of use of this manual. BRUKER BIOSPIN AG accepts no liability for any mistakes contained in the manual, leading to coincidental damage, whether during installation or operation of the instrument. Unauthorised reproduction of manual contents, without written permission from the publishers, or translation into another language, either in full or in part, is forbidden.

This manual was written by

Joerg Arnold/ Daniel B. Baumann
magnetics@bruker.ch

© 12.10. 2004: BRUKER BIOSPIN AG

CH-8117 Faellanden, Switzerland

P/N: Z31326
DWG-Nr: 1036006

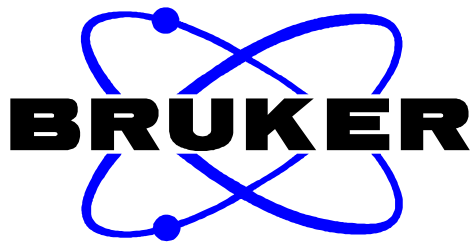

BRUKER BIOSPIN AG

Low Loss Cryostats

Superconducting Magnets

phone: ++41 44 825 91 11

fax: ++41 44 825 923 60

e-mail: magnetics@bruker.ch

service@magnetics.bruker.ch

sales@magnetics.bruker.ch

USERS MANUAL
FOR ULTRASHIELD™
NMR MAGNET SYSTEMS
Refilling Procedure Nitrogen
Refilling Procedure Helium

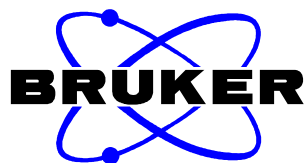
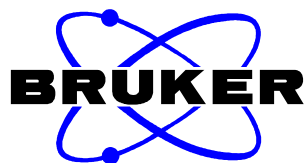

Table of Contents

1	Safety during Refilling Procedure	3
1.1	Introduction	3
1.2	Protection from Magnetic Field	4
1.3	Protection against Ultra-Low Temperatures	4
1.4	Protection from Gases	5
1.5	Protection against Fire and Explosion Risks	5
1.6	Protection against Explosion Risks due to High Pressure transport vessels	5
1.7	Physical Properties of Nitrogen	6
1.8	Physical Properties of Helium	7
1.9	First Aid after Accidents with Cryogenic Fluids	7
1.10	Protection against Mechanical Danger	7
2	Transport Vessel for Liquid Nitrogen	8
2.1	Danger source - Ultra-low Temperature	8
2.2	Requirements for Nitrogen Transport Vessel	8
2.3	Main components	9
3	Magnet System with N2 Flow System	10
4	Measurement of Fluid Level	11
4.1	Tools for Fluid Level Measurement	11
4.2	Measuring the Fluid Level with a Dip-stick	11
4.3	Measuring the Fluid Level with the Epoxy rod	11
5	Transfer Preparation	13
5.1	Preparing the Transport Vessel	13
5.2	Preparing the Magnet System	13
6	Filling procedure	14
6.1	Establishing Connection and Nitrogen Transfer.	15
6.2	Terminating the Filling Procedure	16
6.3	Return to Standard Operation after the Filling Procedure	16
6.4	Recording the Filling Procedure	17
7	Transport Vessel for Liquid Helium	18
7.1	Danger source: Ultra-low Temperature	18
7.2	Requirements for Helium Transport Vessel	18
7.3	Main components	19
8	Transfer Line	20
9	Magnet System	21
10	Fluid Level Control	23
10.1	Measuring the Fluid Level in the Magnet System	23
10.2	Measuring the Fluid Level in the Transport Vessel	23
11	Preparation for Transfer	25
12	Filling procedure	26



12.1	Cooling the Transfer Line	27
12.2	Connecting the Transfer Line	28
12.3	Generating Over Pressure in the Transport Vessel	28
12.4	Helium Transfer	28
12.5	Monitoring the Helium Transfer	29
12.6	Ending the Filling Procedure and Removing the Transfer Line	30
12.7	Return to Standard Operation after the Filling procedure	30
13	Final stages	31
13.1	Recording the Filling Procedure	31
13.2	Control Checks	31
14	Important terminology	32
15	Warning Signs / Pictograms	34

Safety

1 Safety during Refilling Procedure

During the refilling procedure, it is necessary to enter the marked danger area of the magnet system. In order to eliminate the danger associated with this you must adhere to the following safety precautions.

1.1 Introduction

Read the following safety instructions carefully and make them accessible to everybody working around magnet systems and especially magnet stands.

Terms and Symbols: Within this manual there are different terms and symbols used:



Warning: Disregard of this may lead to personal injury.



Caution: Disregard of this may permanently damage the system.



Important: Disregard of this can lead to malfunctions.



Note: Hint for good operating practice.

1.2 Protection from Magnetic Field

The magnet system generates a very strong magnetic field. It can influence electronic devices, magnetic media and ferromagnetic metals. Please observe the following warning notes for protection against the effects of the magnetic field.

**Warning**

Danger of heart seizure for persons with pace-makers. Persons with pace-maker implants must not under any circumstances enter the marked danger zone, or carry out the refilling procedure.

**Warning**

Danger of injury due to flying metal parts. Do not use any magnetic tools or objects in the marked area. You could be hit by a piece of metal flying uncontrollably under the influence of the magnetic field.

**Caution**

Data on magnetic based storage media can be destroyed by the magnetic field. Do not carry any credit cards or similar objects with magnetic identification, when entering the marked area.

1.3 Protection against Ultra-Low Temperatures

Liquid nitrogen has a temperature of -196°C , and liquid helium has a temperature of -269°C . If the skin comes into contact with splashes of cryogenic fluids, this can lead to severe cold-burns.

**Warning**

Danger of blindness if liquid nitrogen comes into contact with the eyes. Always wear protective goggles when carrying out the refilling procedure.

**Warning**

Danger of severe cold-burns if skin comes into contact with cryogenic fluids. There is also a danger of skin adhesion with super cooled metal parts. Always wear protective gloves and closed clothing when carrying out the refilling procedure.

**Important**

The O-rings of the magnet system are also sensitive to low temperatures. Make sure that no liquid helium or liquid nitrogen comes into contact with the O-rings during the refilling procedure. The most endangered O-rings are located in the dewar flange, in the reduction flanges and in the closure flanges at the upper and lower end of the room temperature bore tube.

1.4 Protection from Gases

Evaporation of cryogenic fluids like helium and nitrogen can lead to suffocation, if the oxygen content in the immediate atmosphere, as required by the human body, is reduced.

Helium Gaseous is very light and rises up to the ceiling. Danger of suffocation due to helium is increased when working high up, for instance on a pedestal or ladder.

Nitrogen Gaseous is very heavy and sinks to the floor. Danger of suffocation increases when working near floor level or in pits.

**Warning**

Danger of suffocation from excess gases caused by spilled cryogenic liquids, and from a quench. Make sure that the area is well ventilated and avoid working high up or low down (depending on the type of cryogenic fluid) after a quench.

1.5 Protection against Fire and Explosion Risks

The extremely low temperatures associated with cryogenic fluids lead to condensation of the air's oxygen on the cold pipes. The condensed oxygen drips down and can combust spontaneously when coming into contact with oil or fat. Also contact with flames (e.g. lighters or lit matches) can result in explosive combustion.

**Warning**

Danger of self-combustion or explosion. Respect the smoking ban during the refilling procedure, do not produce any flame of any sort and make sure that the immediate vicinity of the magnet system is clean (without oily cloths and similar things).

1.6 Protection against Explosion Risks due to High Pressure transport vessels

Cryogenic liquids, even when kept in insulated storage vessels (dewar vessels), remain at a constant temperature by their respective boiling points and will gradually evaporate.

The very large increase in volume accompanying the vaporization of the liquid into gas and the subsequent process of warming up is approximately 700:1 for helium and nitrogen and therefore:

**Caution**

Do not use cryogenics that have been stored in high pressure containers for cryogenic liquids! If no other containers are available the pressure must be released completely before connecting the high pressure transport container to the cryostat. This would present an explosion hazard for the magnet system and could lead to severe damage!

Temperature rise

The high pressure within high pressure transport containers leads to a large increase of the boiling temperature of the liquid gas. Transferring such overheated liquid gas into the low loss cryostat will result in very high boil off and strong oscillations until the liquid gas has cooled down to the boiling temperature at atmospheric pressure again!



Temperature diagram

The pressure dependence of the boiling temperature and thus of the temperature of liquid nitrogen stored at a given pressure within a transport vessel is given in the diagram below. As soon as the pressure is released the liquid will start to boil off strongly and will reduce its temperature back to 77 K at atmospheric pressure.

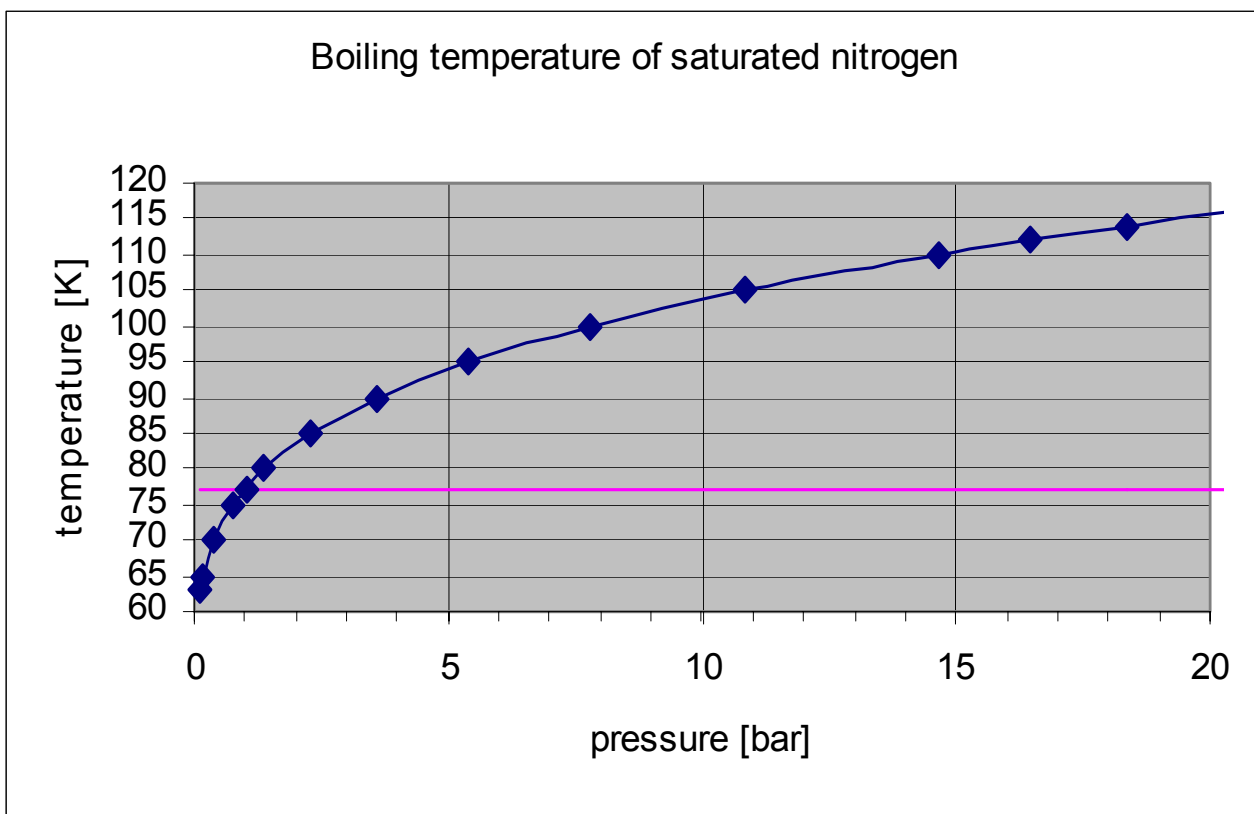

Warning:

Containers for cryogenic liquids must not be closed completely as this would result in a large build up of pressure. This will present an explosion hazard and leads to large product losses!

1.7 Physical Properties of Nitrogen

Liquid nitrogen is boiling at a temperature of -196°C. Nitrogen is colorless, odorless and not inflammable!

Identification:

22
1977

Heating leads to pressure increase and danger of bursting. Spilled fluid is extremely cold and evaporates very quickly. Fluid leads to severe cold burns and severe eye injuries. Gas causes suffocation without preceding symptoms. Nitrogen gas has a higher density than air, is sinking to the floor and is spreading along the floor. Together with moist air, production of fog is observed.

1.8 Physical Properties of Helium

Liquid Helium is boiling at a temperature of -296° . Helium is colorless, odorless and not inflammable!

Identification:

22
1963

Heating leads to pressure increase and danger of bursting. Spilled fluid is extremely cold and evaporates very fast. Fluid leads to cold burns and eye injuries. Gas causes suffocation without preceding symptoms. Helium gas has a lower density than air, is rising to the ceiling and is spreading along the ceiling. Together with moist air, production of fog is observed.

1.9 First Aid after Accidents with Cryogenic Fluids

Get injured people to safety. Injured people must lie comfortably. Remove tight clothes! Immediately remove wet clothes and thaw wound parts of the body with warm water. Do not rub frozen parts of the body. Cover them with sterilized sanitary pads.

1.10 Protection against Mechanical Danger

To isolate the magnet system as well as possible from mechanical disturbances from the environment, inflatable rubber buffers or other shock absorbing components are often used. They protect the magnet system from vibration, but the system is still sensitive to lateral shocks.



Caution

Danger of overturning when moving or mounting the magnet system. When moving the magnetic system, follow the corresponding instructions in the magnet manual. It is strictly forbidden to climb the magnet system.

Nitrogen Refilling Procedure

2 Transport Vessel for Liquid Nitrogen

There are various forms of transport vessels for liquid nitrogen (chemical formula N_2). Described here are the characteristics which are valid for all vessel implementations and which you should be aware of for a safe execution of the refilling procedure.

2.1 Danger source - Ultra-low Temperature

The transport vessel contains liquid nitrogen with a temperature of -196°C . Please observe the warning notes in chapter 1 "[Safety during Refilling Procedure](#)", page 3.

2.2 Requirements for Nitrogen Transport Vessel

The transport vessel must fulfil the following requirements.

- It must not be ferromagnetic. That means it must not be made up of any material, which is susceptible to magnetic fields.



Warning

Danger of injury: Magnetic transport vessels could be pulled uncontrollably towards the magnet system and could trap or crush people.



Caution

Danger of destruction of the magnet system. Magnetic transport vessels could be pulled uncontrollably towards the magnet system and lead to destruction.

- It must possess a pressure release valve, which releases evaporating nitrogen.
- For fluid extraction, a transfer hose must be used which either has a metallic sleeve or is made of Teflon.



Warning

Danger of injury due to plastic hoses splintering under extremely low temperature conditions. Use only specified hoses made of Teflon or a surrogated PFA hose.



Note

A complete **Nitrogen Refilling Set**, consisting of surrogated PFA hose and the necessary adaptors, is available from BRUKER BIOSPIN AG as Part Number Z53144.

2.3 Main components

A transport vessel for liquid nitrogen consists of the following main components:

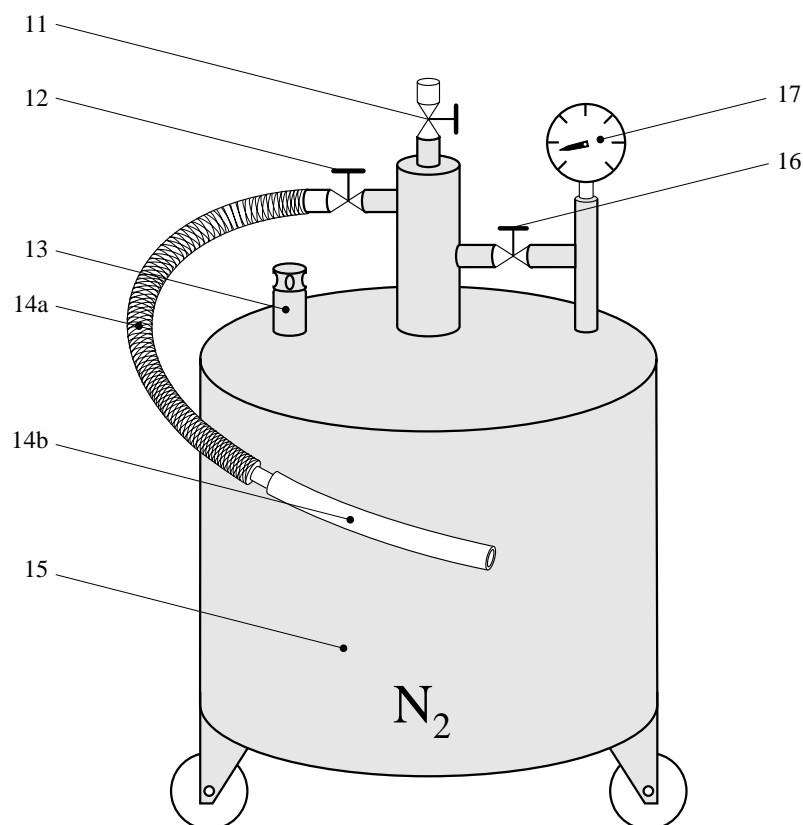

Transport vessel for liquid nitrogen

Legend

- 11 Gas release valve
- 12 Liquid nitrogen extraction tap
- 13 Excess-pressure release valve
- 14a Transfer hose with meshed metal sleeving
- 14b Teflon transfer hose or surrogated PFA hose
- 15 Transport vessel
- 16 Pressure generation armature
- 17 Manometer

3 Magnet System with N₂ Flow System

Described here after are the individual elements common to all magnet systems with N₂ flow systems, which you should know about and observe to ensure safe execution of the nitrogen refilling procedure.



Caution

The magnet system contains liquid nitrogen and a magnet that produces a very strong magnetic field. Please observe the safety measures as described in chapter 1 "Safety during Refilling Procedure", page 3.

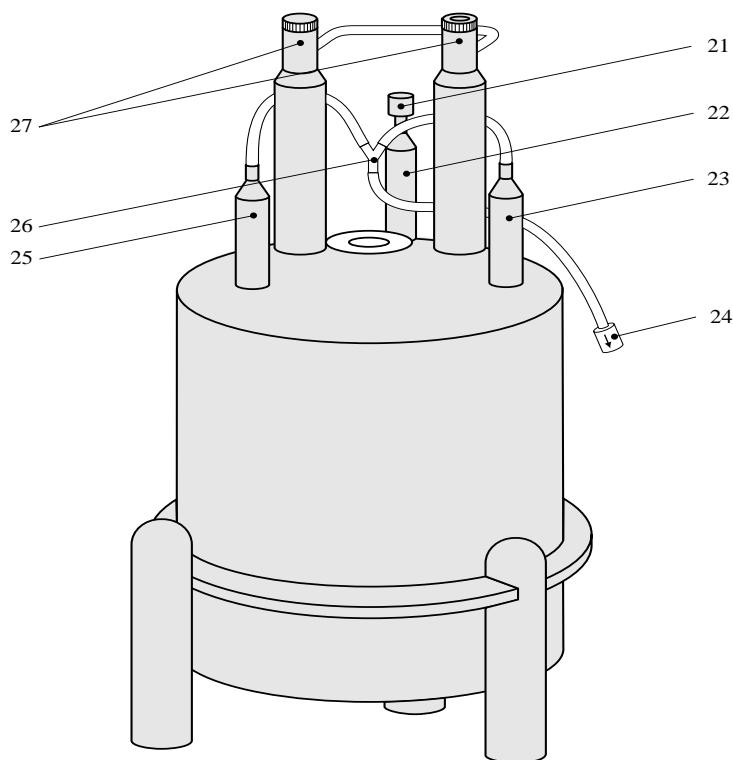

Magnet System with N₂ Flow System

Legend

21	Safety valve	25	Left-hand nitrogen turret
22	Rear nitrogen turret	26	N ₂ flow system
23	Right-hand nitrogen turret	27	Helium turrets
24	Check valve		

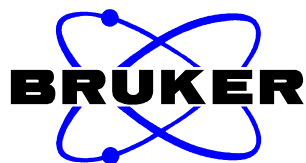

4 Measurement of Fluid Level

The fluid level measurement indicates how much nitrogen needs to be added. Depending on the required quantity, the filling process will take between 5 and 15 minutes.

4.1 Tools for Fluid Level Measurement

The easiest way to measure the fluid level is by means of a dip-stick. This is a long tube with a round end-piece, available as Part Number Z27451 from Bruker. If you do not have a dip-stick available you can also carry out the fluid level measuring process with the help of an epoxy rod.

4.2 Measuring the Fluid Level with a Dip-stick

Follow the procedure outlined below:

1. Slowly insert the dip-stick into the right-hand nitrogen turret (23) and observe the upper end-piece.



Warning

Danger of eye injury by spraying nitrogen. Wear protective goggles during this process.

2. Stop inserting as soon as nitrogen starts to spray out of the end-piece of the dip-stick.

The nitrogen starts to spray out when the warm end of the dip-stick dips into the cold nitrogen fluid. The boiling and evaporating nitrogen is hurling nitrogen splashes through the hollow centre of the dip-stick.

3. Take note of the position of the dip-stick, by taking hold of it directly at the end of the nitrogen turret and pull it out of the vessel.
4. Determine the fluid level, by holding the dip stick next to the magnet system: The lower end indicates the current level of liquid nitrogen.

4.3 Measuring the Fluid Level with the Epoxy rod

Follow the procedure outlined below:

1. Slowly insert the epoxy rod into the right hand nitrogen turret (23) until it touches the floor of the vessel.
2. Let the epoxy rod cool off on this position and take note of its position by taking hold of it directly at the entrance of the turret.
3. Pull the rod out of the vessel and swing it about in the air.

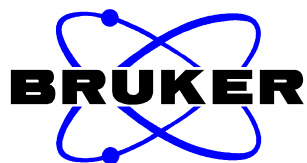

Note

The rod is now covered with a layer of ice along the length of the stick which was submerged in the liquid nitrogen.

4. Determine the fluid level by holding the rod next to the magnet system: The position where the layer of ice starts indicates the current liquid nitrogen level.

5 Transfer Preparation

5.1 Preparing the Transport Vessel

Follow the procedure outlined below:

1. Reduce the pressure to a **maximum of 0.35 bar**, by opening the gas release valve (11).
2. Close all other valves and taps.

5.2 Preparing the Magnet System

Follow the procedure outlined below:

3. If the magnet system is equipped with vibration dampers: Let the air escape out of the dampers by turning the switch on the base plate to the "Down" position.
4. Pull out the hose of the N₂ flow system (26) from the front nitrogen turret, and if there is a heat exchanger present, remove it.



Note

Not all magnet systems possess a heat exchanger. Heat exchangers are fastened onto the nitrogen turrets and inhibit icing up of the outlets.

5. Check that the outlets at both of the front nitrogen turrets are free (23, 25).

You can check whether the outlets are free by observing whether evaporating nitrogen is escaping from them. Another possibility is to carefully insert a thin rod through the nitrogen turrets into the tank.



Caution

Never try to remove ice from the nitrogen turrets without prior contact with your local Bruker Service Department.

6. Insert a Teflon hose onto the left-hand turret (25) and fasten the end so that it is pointing away from the magnet system.



Note

For this it is easiest to use the corresponding hose from the N₂ flow system.

7. Check the current fluid level in the nitrogen tank in the right-hand turret (see section 4 "[Measurement of Fluid Level](#)", page 11).



Caution

Danger of the magnet system bursting due to excess pressure. Always leave the safety valve (21) in its correct position.

6 Filling procedure

Connect the transfer hose from the transport vessel to the magnet system. With a slight pressure differential (maximum 0.35 bar), the nitrogen will be drawn from the transport vessel into the magnet system. The end of the filling process can be recognized in that nitrogen will start spraying out of the left hand turret.

The connection between the transport vessel and the magnet system is made by the transfer hose.

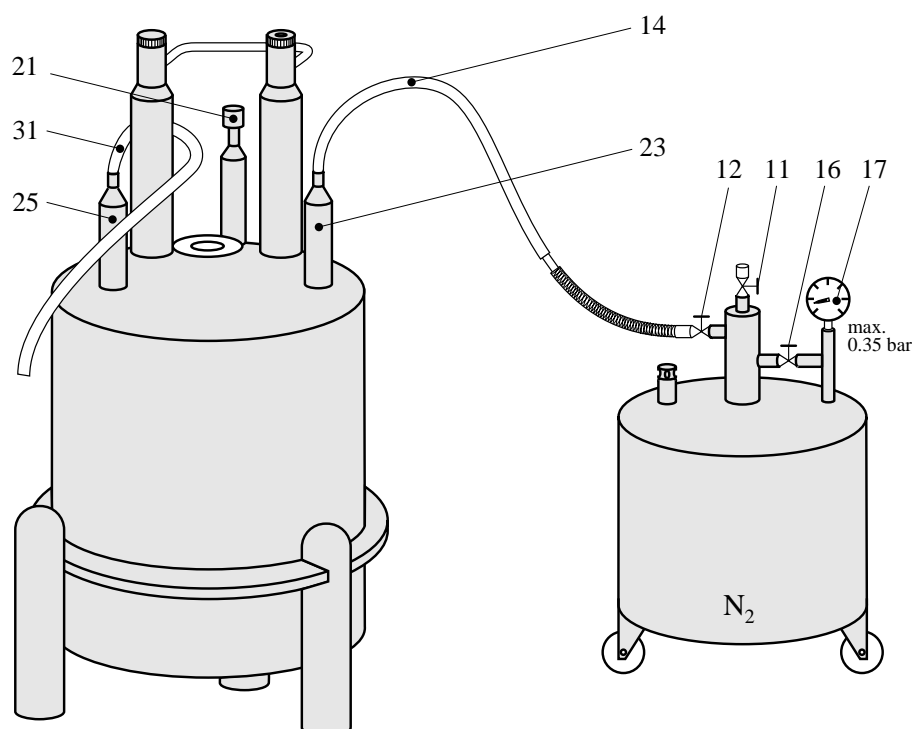

System prepared for N₂ filling procedure

Legend

- 11 Gas release valve
- 12 Liquid nitrogen extraction tap
- 14 Transfer hose
- 16 Pressure generation armature
- 17 Manometer
- 21 Safety valve
- 23 Right-hand nitrogen turret
- 25 Left-hand nitrogen turret
- 31 Teflon hose

6.1 Establishing Connection and Nitrogen Transfer.

1. Insert the free end of the transfer hose (14) onto the right-hand nitrogen turret (23).
It suffices to make sure that it is firmly placed. You do not require any additional fastening means.



Note

Make sure that the transfer hose is not creased or kinked, otherwise problems may occur with the filling process.

2. Supervise the entire filling procedure so that you can immediately intervene should the pressure exceed 0.35 bar or when the filling procedure is ended.
3. Make sure that the pressure in the transport vessel is not higher than 0.35 bar. You can regulate the pressure by opening the gas release valve (11) (for pressure decrease) or by pressing the armature (16) (for pressure increase).



Caution

Danger of explosion due to excess pressure. Respect the allowed maximum pressure of 0.35 bar at all times.

4. Open the liquid nitrogen extraction tap(12) and check whether nitrogen is being drawn through the transfer hose.



Note

If you are using a Teflon transfer hose it is easy to visually observe whether the filling procedure is running correctly.

5. Check whether gas is escaping from the Teflon transfer hose (31) at the left-hand nitrogen turret. That indicates that the turret is free and not iced up.



Warning

Danger of eye injury, due to splashes of ultra-cold liquid nitrogen. Make sure that nobody is positioned near the areas where nitrogen is escaping from the hose.

6. By observing the manometer (17), ensure that the pressure does not exceed 0.35 bar during the entire filling procedure and that the left-hand turret is always free (gas escaping at the Teflon hose).
7. Check whether the transport vessel contains enough fluid.



Note

The pressure indicated on the manometer (17) starts to rapidly sink as soon as the transport vessel becomes empty.



Note

The end of the filling procedure is recognized when liquid nitrogen starts spraying out of the left-hand nitrogen turret.

6.2 Terminating the Filling Procedure

The filling procedure is completed when nitrogen starts spraying out of the Teflon hose on the left-hand nitrogen turret.

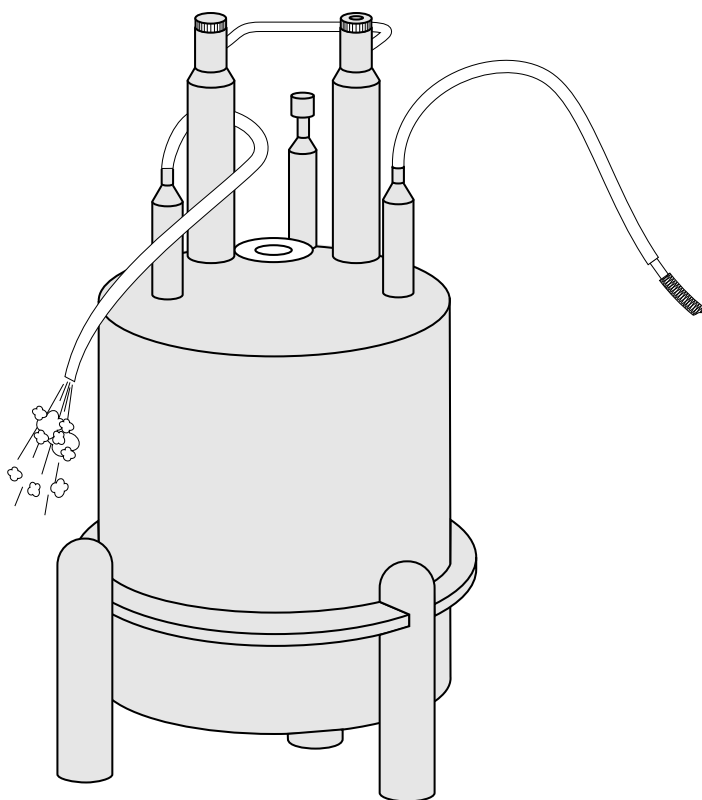

End of the filling procedure

1. Stop the filling procedure by closing the liquid nitrogen extraction tap (12) and/or
2. releasing the pressure in the transport vessel by means of the pressure release valve (11).
3. Close the pressure exertion armature (16).

6.3 Return to Standard Operation after the Filling Procedure

After the filling procedure has been completed, follow the procedure outlined below.

1. Let the transfer hose (14) thaw out by waiting for about 10 minutes and/or
2. carefully warm the end of the transfer hose with a fan-heater.
3. Remove the transfer hose (14) from the right-hand nitrogen turret (23) of the magnet system.
4. Remove the Teflon hose (31) from the left-hand nitrogen turret (25).



Caution

5. Check that the neck tubes on both turrets are free (visible escaping of gas, or insertion of dip-stick).

Never try to remove ice from the nitrogen turrets without prior contact with your local Bruker Service Department.



Note

6. Connect the N₂ flow system (26)

Make sure that the check valve (24) is correctly mounted (arrow in direction of nitrogen flow) to allow the nitrogen gas to escape from the nitrogen tank.

7. If the magnet system is standing on vibration dampers: Activate the dampers by turning on the switch on the base plate to the "up" position.

6.4 Recording the Filling Procedure

The filling procedure replaces the evaporated nitrogen. If the filling procedure is accurately recorded, the average consumption can be estimated. Significant changes in nitrogen consumption is an early warning signal that the magnet system is not in order.

1. Record the date of the filling procedure and the quantity of nitrogen used.

Helium Refilling Procedure

7 Transport Vessel for Liquid Helium

There are various forms of transport vessels for liquid Helium (chemical formula He). Described here are the characteristics which are valid for all vessel implementations and which you should be aware of for a safe execution of the refilling procedure.

7.1 Danger source: Ultra-low Temperature

The transport vessel contains liquid Helium with a temperature of -269°C . Please observe the warning notes in chapter 1 "[Safety during Refilling Procedure](#)", page 3 when dealing with the transport vessel.

7.2 Requirements for Helium Transport Vessel

The transport vessel must fulfil the following requirements:

- It must not be ferromagnetic. That means it must not be made up of any material, which is susceptible to magnetic fields.
- It must possess a fixed, mounted safety valve which cannot be externally influenced.
- It must possess a pressure release valve, which releases evaporating Helium.



Warning

Danger of injury: Magnetic transport vessels could be pulled uncontrollably towards the magnet system and could trap or crush people.



Caution

Danger of destruction of the magnet system. Magnetic transport vessels could be pulled uncontrollably towards the magnet system and lead to destruction.

7.3 Main components

A transport vessel for liquid Helium consists of the following main components:

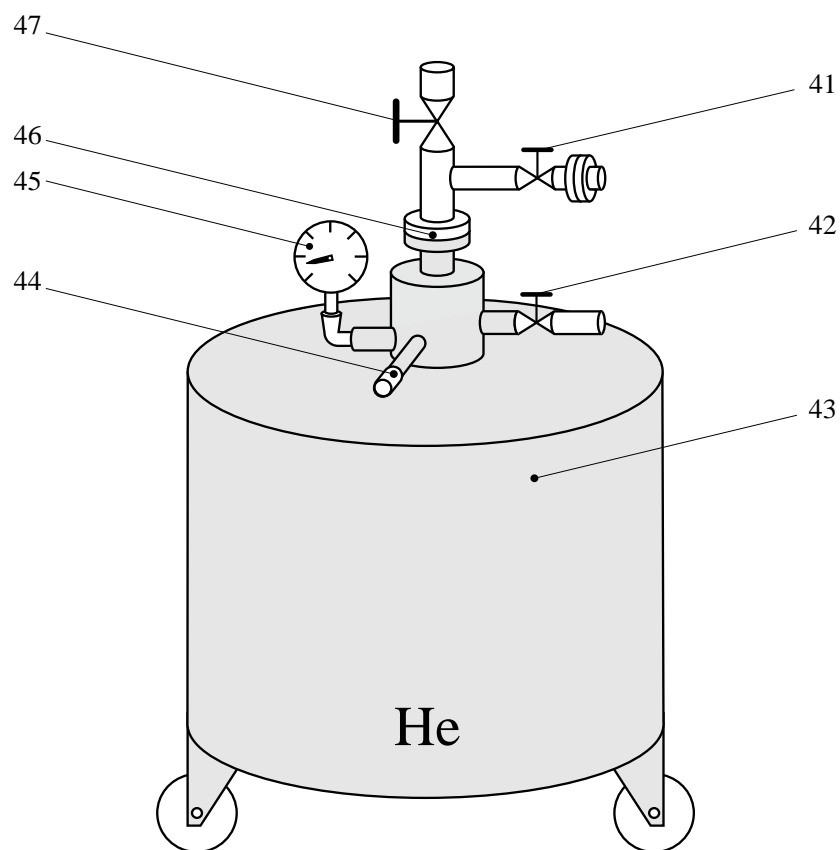

Transport vessel for liquid Helium

Legend

- 41 Gas release valve (and /or valve for pressure generation)
- 42 Pressure release valve (with locking tap)
- 43 Transport vessel
- 44 Safety valve
- 45 Manometer
- 46 Connection flange
- 47 Extractor tap (ball-bearing valve) for liquid helium

8 Transfer Line

Due to the extremely low temperature of liquid helium, a special transfer line is required for the filling procedure. It is double-skinned, insulated and evacuated.



Note

Do not use any other type of pipe or a damaged transfer line. The pipe would ice up and the helium would evaporate due to the faulty isolation.



Caution

In case of problems with a transfer line, please contact your local Bruker Service Department.



Note

You can recognize a defective transfer line in that the defective area ices up (becomes frosty white) during the helium transfer process.

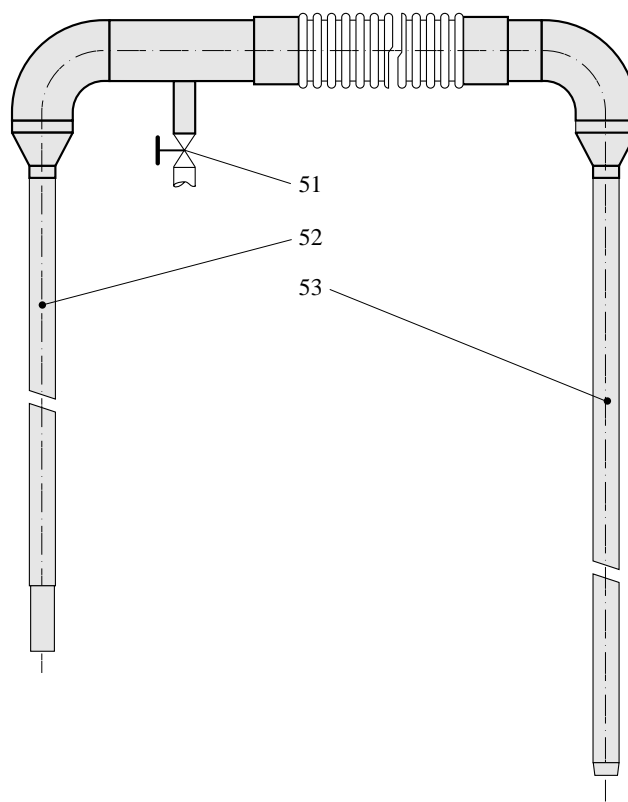

Transfer Line

Legend

- 51 Transfer line evacuation valve
- 52 Connector tube - Magnet side
- 53 Connector tube - Transport vessel side

9 Magnet System

Described here after are the individual elements common to all magnet systems, which you should know about and observe to ensure safe execution of the helium refilling procedure.



Caution

The magnet system contains liquid helium and a magnet that produces a very strong magnetic field. Please observe the safety measures as described in chapter 1 "Safety during Refilling Procedure", page 3.

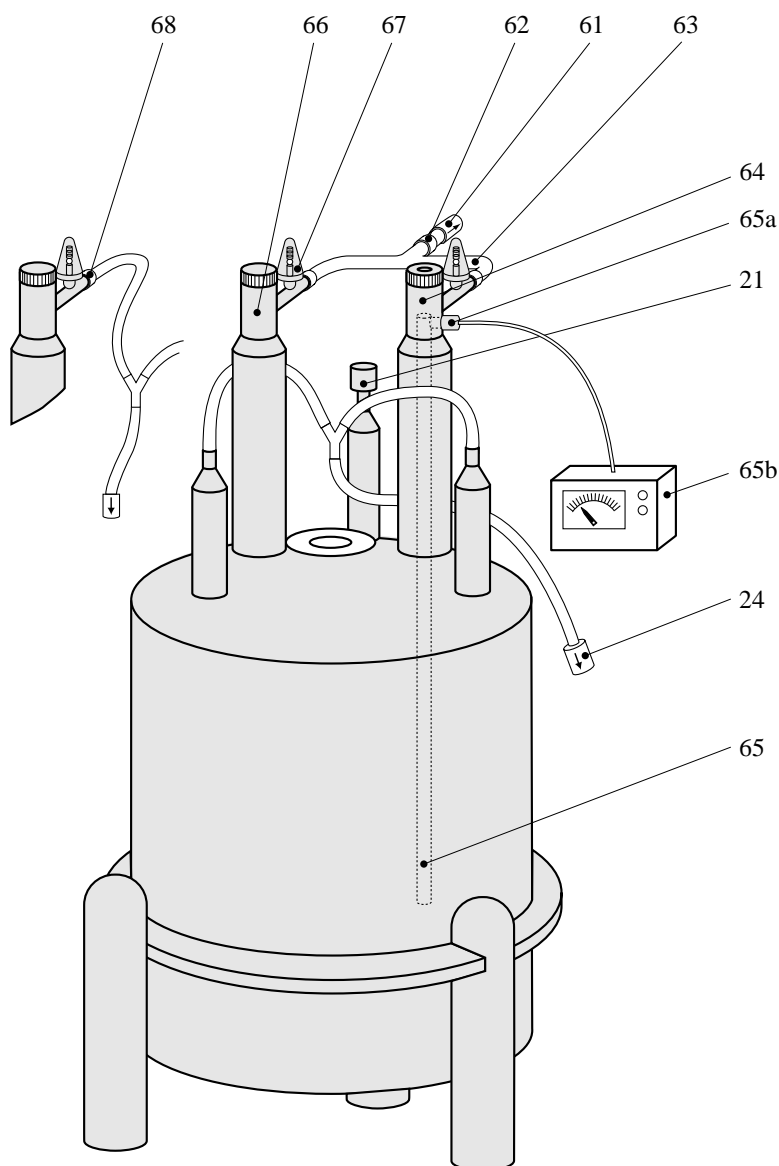

Magnet System

Legend

- 21 Safety valve (for nitrogen)
- 24 Check valve (for nitrogen)
- 61 Check valve (for helium)
- 62 Helium oscillation damper
- 63 U-tube
- 64 Right helium turret with siphon
- 65 Helium level sensor
- 65a Connector to the helium level sensor
- 65b Helium level meter
- 66 Left-hand helium turret
- 67 Quench valve
- 68 Adapter with hose



Note

Not all magnetic systems are equipped with a U-tube (63). As an alternative to this, there are systems which possess adapters with hoses (68) at both helium turrets. These hoses are connected together by means of a Y-piece and ventilated via the check valve (61).



Caution

Magnet systems with the Silicon tubes and this Y-piece must be completely closed on the refill turret side. Only then no air will be sucked into the magnet during the refilling.

10 Fluid Level Control

The fluid level measurement in the magnet system indicates how much Helium needs to be added. Fluid level measurements in the transport vessel enables you to determine the effective quantity of helium used. During the filling procedure you can only check whether the transport vessel still contains any helium.

10.1 Measuring the Fluid Level in the Magnet System

The magnet system provides a fixed, built-in helium level sensor to measure the fluid level (65). You can connect a helium level meter (65b) to the standardized connector (65a). Please read the operating instructions of your helium level meter.

10.2 Measuring the Fluid Level in the Transport Vessel

Measurement of the fluid level in the transport vessel is only possible before or after the filling procedure. During the filling procedure you can only check whether the transport vessel still contains any helium.



Note

You will need a dip-stick to measure the fluid level. This is a long tube with a round end-piece, available as Part Number Z27451 from BRUKER BIOSPIN AG.

Measuring the fluid level

To measure the fluid level in the transport vessel you need finger-tip feeling in every sense of the word! Follow the procedure outlined below:

1. Release the pressure in the transport vessel by opening the gas release valve (41).
2. Open the helium extraction tap (47) and insert the dip-stick carefully until it reaches the floor of the transport vessel.
3. Mark the position of the dip-stick by holding it at the entrance of the extraction tap.
4. Seal the upper end of the dip-stick with the thumb of your other hand (moistened beforehand) or a small piece of plastic, so that you can feel and hear a fine sizzling of the helium gas.
5. Slowly pull the dip-stick out until you notice a clear change of the "sizzling frequency".



Note

The frequency of the sizzling sound will become significantly higher as soon as the end of the dip-stick surfaces above the level of the liquid helium. If you are not certain whether you have passed this transition point or not, you can repeat the process by pushing the dip-stick deeper down in the tank and trying again.

6. Mark the position of the dip-stick at the transition point, by holding it directly at the extraction tap.

7. Measure the distance between both markings on the dip-stick and determine the fluid level on the fluid level table of the transport vessel.
8. Close the gas release valve (41) and the liquid helium extraction tap (47).

Checking of the fluid level

During the refilling procedure, only an indirect checking of the presence of remaining fluid in the transport vessel is possible.

The easiest way of checking this is by reading the helium level meter (65b) on the magnet system. If the fluid level indicator slowly and continually increases, you can be sure that the transport vessel still contains fluid.



Note

The helium level sensor is very sensitive on icing. In case of icing it does not function any more and will indicate an arbitrary but stable value. Some helium level meters are equipped with a de-icing function. Please consult the respective manual.



Caution

If the icing can not be removed, please contact your local Bruker Service Department.

A slight over pressure can be generated in the transport vessel with the help of a rubber bladder (e.g. the inside skin of a football). You can determine whether the transport vessel is empty by observing the rubber bladder. If it does not stay firmly pressurized, the vessel must be empty, as no more over pressure can be generated.

In order to generate the over pressure externally with helium gas, follow the procedure outlined below:

1. Close the pressure generation valve (41) and remove the hose which delivers the external helium gas.
2. Open the pressure generation valve (41) and observe whether the transport vessel is under pressure.



Note

No pressure can be generated in an empty transport vessel, as the gas can escape directly into the magnet system via the transfer line.

3. Close off the hose for delivering external helium gas and open the pressure generation valve (41) to continue the filling procedure.

11 Preparation for Transfer

Prepare the magnet system for helium transfer by following the procedure outlined below:

1. If the magnet system is equipped with vibration dampers: Let the air escape out of the dampers by turning the switch on the base plate to the "Down" position.
2. Make sure that the nitrogen outlets are correctly closed with a check valve, or if necessary, close the outlets with a rubber stopper.



Caution

Danger of excess pressure in the magnet system when using rubber stoppers. Remove the rubber stoppers after the filling procedure has been completed.

Closing the nitrogen outlets makes sure that the super cooled magnet system does not suck air into the nitrogen tank. A correctly mounted check valve (24) (arrow pointing outwards) is sufficient for this purpose.

3. Make certain that the N₂ safety valve (21) is mounted onto the rear nitrogen turret.



Caution

Danger of the magnet system bursting. Always leave the safety valve and quench valves in their correct positions.

12 Filling procedure

Before starting the filling process the transfer line must first be cooled down. After the transfer line has been cooled down you can make the connection between the transport vessel and the magnet system. The helium will be drawn from the transport vessel into the magnet system via the transfer line when a slight over pressure established. The filling process is finished when liquid helium starts coming out of the outlet.

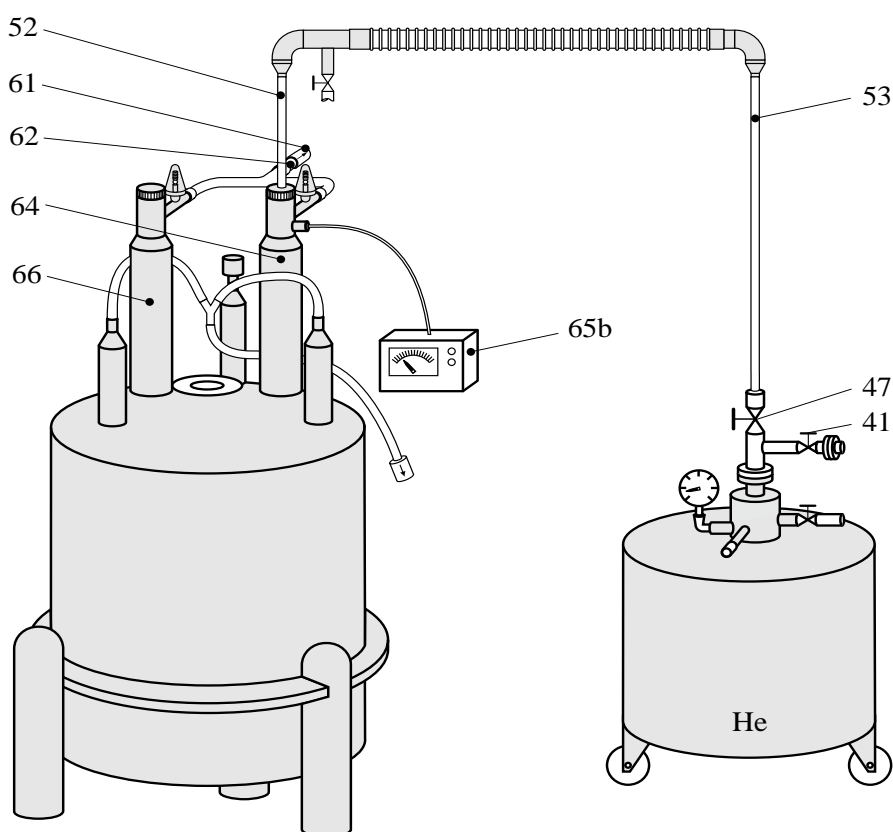

System during filling procedure

Legend

- 41 Gas release valve (and /or valve for pressure generation)
- 47 Extractor tap (ball-bearing valve) for liquid helium
- 52 Connector tube - Magnet side
- 53 Connector tube - Transport vessel side
- 61 Check valve (for helium)
- 62 Helium oscillation damper
- 64 Right helium turret with siphon
- 65b Helium level meter
- 66 Left-hand helium turret

12.1 Cooling the Transfer Line

If a warm transfer line is inserted into the magnet system, the warm helium gas coming out of the transfer line, could cause a very strong reaction called a quench. You can prevent this by first cooling the transfer line. Follow the procedure outlined below.

**Caution**

Carefully read the following instruction steps before carrying out this procedures!

1. Remove the check valve (61) and if applicable the oscillation damper (62), or
2. remove the adaptor with hose (68) from the left-hand helium turret (66). Close the right hand side completely that no air can be sucked into the magnet system.
3. Close the outlet opening by pressing a tissues lightly into the opening.

**Note**

This minimizes the entrance of air into the helium vessel until you start to fill it with helium. Air entering the vessel will freeze.

4. Release the slight over-pressure in the transport vessel by opening the gas release valve (41) for a short period.
5. Close all taps on the transport vessel.
6. Insert the connecting tube (53) of the transfer line into the liquid helium extraction tap (47) until it reaches the ball-bearing valve.
7. Prepare the right-hand helium turret on the magnet system (64). Remove the screw cap with stopper, washer and O-ring and immediately seal the connector again with the stopper to minimize the entrance of air.
8. Prepare the transfer line for connecting with the magnet system by placing the screw cap with washer and O-ring onto the connecting tube (52).
9. Open the liquid helium extraction tap (47). Push the transfer line slowly into the transport vessel until helium in the form of gas, starts escaping at the other end.
10. Allow the transfer line to cool down until liquid helium starts to exit the open end of the connecting tube (52)

**Note**

You can easily recognize when liquid helium starts coming out. The stream exiting the open end looks like the flame of a candle.

12.2 Connecting the Transfer Line

As soon as the transfer line has cooled down, you can establish the connection between the transport vessel and the magnet system - then the helium transfer can begin.



Caution

Danger of a quench: When inserting an insufficiently cooled transfer line. Cool the transfer line until liquid helium comes out of the open end.

11. Insert the connecting tube (52) of the transfer line (without extension piece) carefully into the right-hand helium turret (64) and fix it with the nut.



Caution

The end of the transfer line must not be submerged into the siphon in the helium tank. Check whether you are using the correct transfer line if you notice that it touches the siphon. Should the transfer line submerge into the siphon and reach the bottom of the siphon, pull back the transferline 2-3 cm (1 inch) and fix it with the screw cap.

12.3 Generating Over Pressure in the Transport Vessel

The helium is transferred from the transport vessel with the help of a slight over pressure. This pressure must not exceed 0.35 bar under any circumstances. You can generate the required pressure as described below:

12. Connect clean helium gas to the pressure generation tap (41) and open the tap until a slight over-pressure is built up in the transport vessel, or...
13. Connect a rubber bladder from the inside of a football, and knead the bladder. By circulating the warm helium gas in the transport vessel, this disturbance leads to sufficient pressure build up.



Note

The insulation of the transport vessel is not perfect. Pressure is built up naturally by permanently evaporating helium. In some cases this is sufficient to generate the required over pressure.



Note

The filling procedure can take up to one hour if you refill when reaching the minimum allowed helium level after the maximum hold time.

12.4 Helium Transfer



Note

As soon as you insert the connecting tube (52), the helium transfer process begins. You can clearly recognize this in that the Kleenex tissue is blown out of the outlet opening.

14. Push the connecting tube (53) into the transport vessel until it reaches the bottom and then pull it back about five centimeters (2

inches). This will prevent the transfer line from becoming blocked during the filling procedure.

15. Switch the helium level meter (65b) to continuous measurement, if possible.
16. Provide a slight over pressure in the transport vessel as required (see section 12.3 "Generating Over Pressure in the Transport Vessel", page 28).

12.5 Monitoring the Helium Transfer

17. Make sure that the pressure does not exceed 0.35 bar during the entire filling procedure.



Caution

Danger of explosion due to excess pressure build-up. Respect the maximum pressure of 0.35 bar at all times.



Note

A pressure of 50 to 100 mbar is usually enough for a satisfactory transfer of helium.

18. During the filling process, check whether the transport vessel contains enough fluid (see section 10.2 "Measuring the Fluid Level in the Transport Vessel", page 23).



Note

You can easily recognize that there is still fluid in the transport vessel by observing the indicator on the helium level meter (65b). As long as it is continually rising, the transport vessel cannot be empty.



Note

The helium level sensor is very sensitive on icing. In case of icing it does not function properly and will indicate an arbitrary but stable value. Some helium level meters are equipped with a de-icing function. Please consult the respective manual.



Caution

If the icing can not be removed, please contact your local Bruker Service Department.

19. Finish the helium transfer process as soon as the helium tank is full.

You can recognize a full helium tank with the following methods:

- The indicator on the helium level meter shows 100%.
- Liquid air (nitrogen and oxygen) drops from the U-tube.



Note

Please observe the warning notes in section 1.5 "Protection against Fire and Explosion Risks", page 5.

- Liquid helium starts to escape from the outlet opening. This looks like a small flame.



Caution

If the icing can not be removed, please contact your local Bruker Service Department.

12.6 Ending the Filling Procedure and Removing the Transfer Line

The filling procedure is ended as soon as liquid helium starts escaping from the outlet opening, which you can recognize by the small "flame" as already described.

End the process as follows:

1. If you have connected an external helium supply for the pressure generation: Close the pressure generation tap (41) and remove the corresponding hose.
2. Release the pressure from the transport vessel by opening the gas release valve (41).
3. Loosen the screw caps and pull the transfer line simultaneously from the helium tank and the transport vessel.



Warning

Danger - Do not touch the ultra-cold connecting tubes of the transfer line. Wear protective gloves when removing the transfer line.

4. Immediately close the right-hand helium turret with the stopper.



Note

Frozen parts made of metal can be thawed out with a fan heater. Do not use excessive temperatures on parts made of plastic.

5. When the transfer line has thawed out, remove the O-ring, washer and screw up and check the O-ring for damage.

12.7 Return to Standard Operation after the Filling procedure

After successful execution of the filling procedure, reverse the procedure as follows:

1. Close all taps and valves on the transport vessel.
2. Open the pressure release valve (41).
3. Close the right-hand helium turret (64) properly with the screw cap, O-ring, washer and valve.
4. Mount the helium check valve (61) on the magnet system such that the arrow is pointing outwards or
5. mount the adaptor with the hose (68) on the left-hand helium turret.

13 Final stages

You should conclude the helium filling procedure by checking whether the magnet system works correctly again and recording the filling procedure.

13.1 Recording the Filling Procedure

The filling procedure replaces the helium lost through evaporation. If the filling procedure is accurately recorded, the average consumption can be estimated. Significant changes in helium consumption is an early warning signal that the magnet system is not in order.

1. Determine the quantity of helium left in the transport vessel (either by weighing, or measuring the fluid level with a dip-stick).
2. Record the date and quantity used on the magnet system and on the transport vessel.
3. Record the helium level before and after the filling procedure.
4. Make sure the nitrogen outlets are correctly fitted with a check valve and if applicable remove the rubber stopper from the outlets.



Caution

Danger of magnet system bursting - This can occur if you forget to remove the rubber stoppers from the nitrogen outlets. After conclusion of the refilling procedure, it is essential that you remove the rubber stoppers.

5. If the magnet system is standing on vibration dampers: Activate the dampers by turning the switch on the base plate to the "up" position.

13.2 Control Checks

After the filling procedure has been completed, carry out the following checks to ascertain whether the magnet system functions correctly.

6. After the helium filling procedure, make sure that the U-tube thaws out. You can help this process by carefully using a fan if necessary.
7. After a few hours, check that evaporating nitrogen is exiting from the nitrogen outlets.



Caution

Danger of magnet system bursting - This can occur if the nitrogen outlets are blocked through icing up. Make sure that the nitrogen outlets are free.



Note

If after a few hours, evaporated nitrogen is not escaping, the cause could be iced up nitrogen turrets. Check that they are free according to [5.2 "Preparing the Magnet System", page 13](#).



Caution

Never try to remove ice from the nitrogen turrets without prior contact with your local Bruker Service Department.

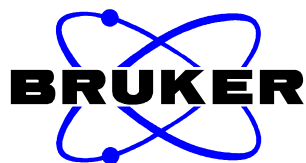

Appendix

14 Important terminology

In this section, the meaning of the most important terminology is explained, in the form of a glossary.

Anti Vibration Feet	Air cushioned damper elements on or in the magnet stand
Cryogenic fluid	Super-cooled gas in fluid form
Dip Stick	Long metal tube with a round end-piece for measuring fluid level
Epoxy Rod	Long fibre glass stick with a diameter of around 1 mm for measuring fluid level.
Flame	Visible appearance of liquid helium escaping from a pipe.
Helium	Light, colorless, odorless and tasteless gas with the chemical formula "He". Liquid helium has a temperature of -269°C
Helium level meter	Measuring device for indicating the fluid level in the helium tank.
Helium level probe	Measuring probe for determining the fluid level in the helium tank
Helium oscillation damper	Part of the U-tube for suppressing thermo-acoustic gas oscillations.
Magnet System	Super-conducting magnet which stands in a tank of liquid helium, surrounded by a second isolation tank containing liquid nitrogen.
Manometer	Gas pressure measuring device.
Nitrogen	Heavy, colorless, odorless gas with the chemical formula "N ₂ ". Liquid nitrogen has a temperature of -196°C
N₂ Flow System	Assembly on the magnet system, which releases evaporated nitrogen into the atmosphere and at the same time prevents air and moisture from entering the nitrogen tank.
Quench	Very fast discharging of the magnet due to loss of its super-conducting properties. A quench happens when the stored magnetic energy is converted to heat, due to loss of super-conductivity. The heat produced results in

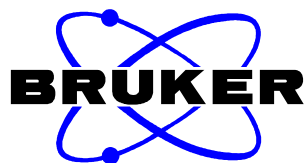

	rapid evaporation of large quantities of helium and nitrogen.
Quench valve	Pressure release valve with large outlet capacity.
Siphon	Metal regulator with tube in the magnet system, which reaches to the floor of the helium tank.
Transfer Line	Vacuum isolated transfer pipe for liquid helium.
Transport vessel	Vacuum isolated vessel for the transportation of liquid helium or nitrogen.
U-tube	Connecting piece which connects the outlets of the two helium turrets.

15 Warning Signs / Pictograms

Caution: Extremely high magnetic stray fields.



Danger: No entrance for people carrying pace-makers.



Danger: No entrance for people carrying medical implants.



Caution: Watches and electronic or electro-mechanical devices may be damaged.



Caution: Credit cards, magnetic storage media as tapes, floppy disks or hard disks, may be damaged.



Note: Exit in case of emergency.

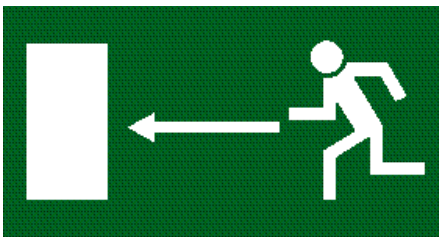

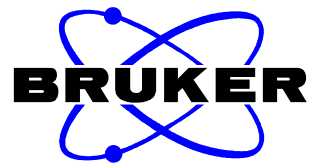

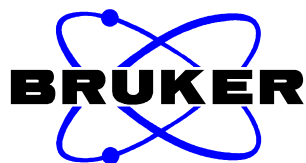

C	Check the Fluid Level 24 Checking that the Outlets are free 13 Connecting the Transfer Line 28 Containers for cryogenic liquids 6 Cooling the Transfer Line 27
D	Danger Danger of heart seizure 4 Danger of Over-turning 7 Danger of Self Combustion or Explosion 7 Danger of severe cold-burns 4 Danger of Suffocation 5
E	Explosion hazard 5
F	Filling Procedure (Helium) 26 Filling Procedure (Nitrogen) 14 Fluid Level Control 23
G	Generating Over Pressure 28
H	Helium Oscillation Damper 22 Helium Transfer 28 High boil off 5 High pressure containers for cryogenic liquids 5
M	Magnet System 10, 21 Measurement of the Fluid Level 11 Measurement of the Fluid Level with a Dip-Stick 11 Measuring the Fluid Level in the Magnet System 23 Measuring the Fluid Level in the Transport Vessel 23 Measuring the Fluid Level with an Epoxy-Rod 11
N	N ₂ Flow System 10 Nitrogen Transfer 15
O	Oscillation Damper 22 Overheated liquid gas 5
P	Pressure dependence of the boiling temperature 6 Protection Protection against Mechanical Danger 7 Protection against Ultra-Low Temperatures 4 Protection from Gases 5 Protection from Magnetic Field 3, 4

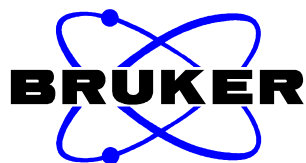

	Protection against explosion risks due to high pressure transport vessels 5
R	Recording the Filling Procedure 31 Removing the Transfer Line 30 Requirements for Nitrogen Transport Vessel 8
S	Strong oscillations 5
T	Temperature diagram 6 Temperature of liquid nitrogen 6 Temperature rise 5 Terminating the Filling Procedure (Helium) 30 Terminating the Filling Procedure (Nitrogen) 16 Tools for Fluid Level Measurement 11 Transfer hose 14 Transfer Line 20 Transfer Preparation 13 Transfer Preparation (Helium) 25 Transport Vessel for Helium 18 Transport Vessel for Liquid Helium 18 Transport Vessel for Liquid Nitrogen 8
U	U-Tube 22
V	Vaporisation 5 Very high boil off 5



Notes:

Bruker BioSpin **your solution partner**

Bruker BioSpin provides a world class, market-leading range of analysis solutions for your life and materials science needs

● **Bruker BioSpin Group**

info@bruker-biospin.com
www.bruker-biospin.com