

How do songbirds sing birdsongs?



Michale Fee (MIT)

Liora Las



Outline:

- 1) Introduction to songbirds as a model.
- 2) Neuronal circuits underlying mature song production (motor system).
- 3) Neuronal circuits underlying early stages of singing (learning system).



Dr. Yarden Cohen
Next week
Thursday 23/4

Is there an innate natural language?

In the 13th century the Holy Roman Emperor **Frederick II** carried out a **deprivation language** experiment on young infants raised without human interaction in an attempt to determine if there was **an innate natural language** that they might demonstrate once their voices matured.

It is claimed he was seeking to discover what language would have been imparted into Adam and Eve by God.

Today there is evidence that basic structure of language, particularly, syntax, may be universal suggesting that its innate... we will get there later

<https://www.historyanswers.co.uk/kings-queens/crusader-queen-sibylla-of-jerusalem-sacrificed-the-holy-city-for-love/>



Medieval monarch **Frederick II** (Holy Roman Emperor, 1194-1250 AD), tried a similar experiment, with disastrous results.

Vocal learning

To get the brain mechanisms that underline vocal learning it will be very useful to have an animal model system.

Vocal learning is not very common in the animal kingdom:

Lots of animals are able to vocalize but they are not necessarily have to hear other or themselves in order to do so.

Mammals:

- Humans
- Other primates (marmosets)??
- Dolphins/ Whales
- Sea lions/ Seals
- Elephants
- Bats

Birds:

- Parrots
- Crows
- Hummingbirds
- **Songbirds**

Over 4000 different species of songbirds

What do songbirds and humans have in common?



Both humans and songbirds **learn** their motor behavior (e.g. vocal) **early in life**.

Both learn to communicate by **listening to their parents**.

They **must be able to hear** their own vocalization in order to learn to sing/speak.

Both humans and songbirds have evolved a complex hierarchy of **specialized brain areas** essential for vocal control.

Birds sing for two main reasons:

1. To attract a mate.
2. To establish and hold a territory.

Within zebra finches:

Males are the only one that sings.

Male's brains are specialized in **singing**, **female's** brains are specialized in **evaluating** the song



There are more than 4,000 species of songbirds

Zebra finch - the lab “rat” of the vocal learning field

- 1) Small and cheep
- 2) We have lots of knowledge
- 3) Relatively short time-window of learning
- 4) Simple song that is super stereotype!

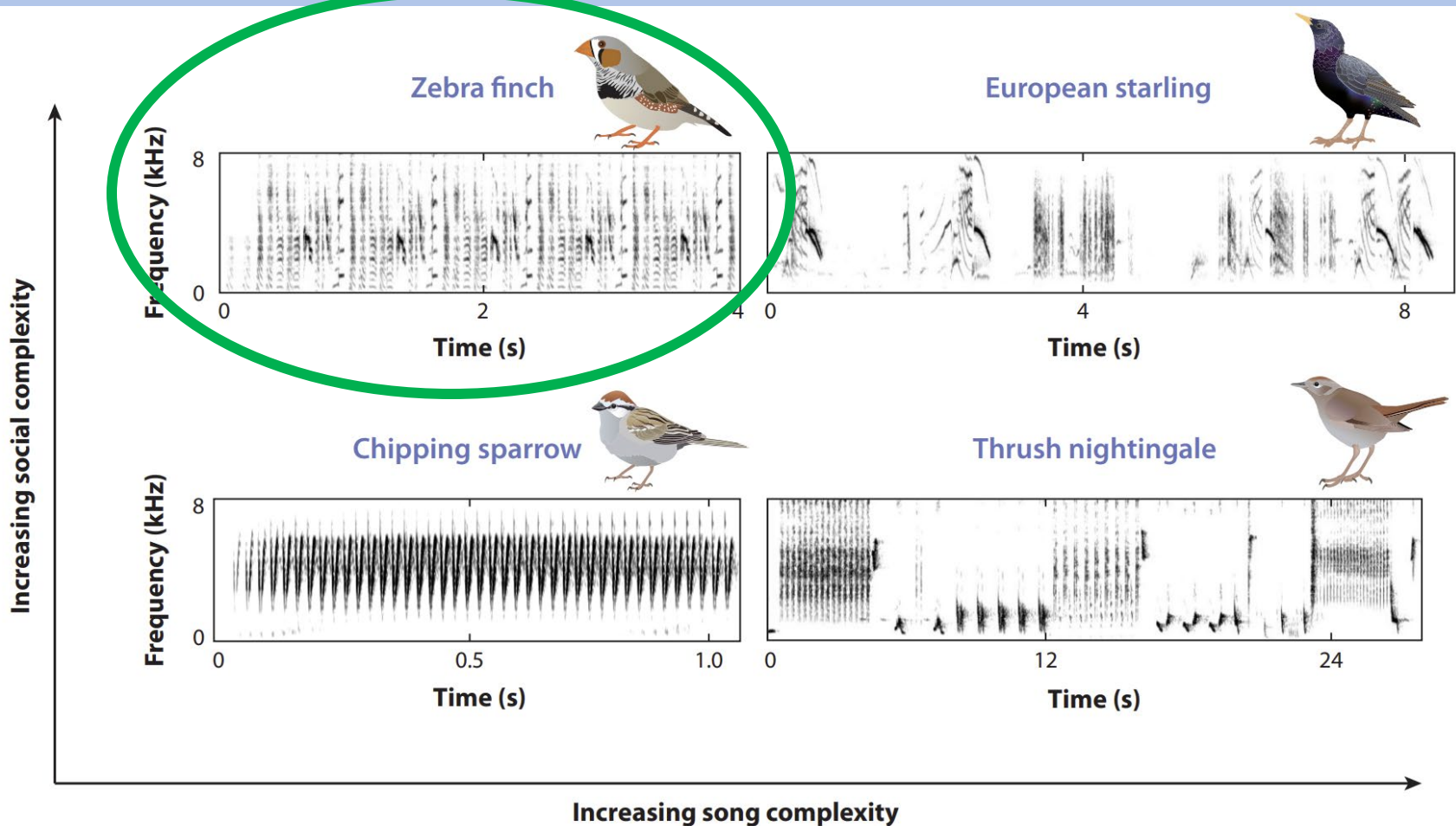

Songbirds sing! Adult song is highly stereotyped

Zebra finch

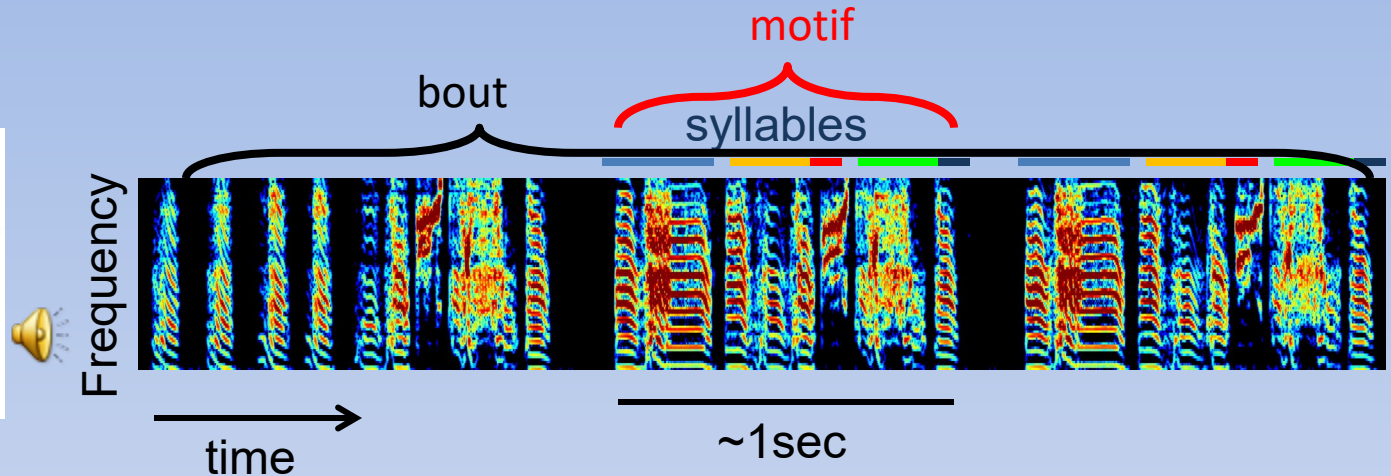

There are two modes of singing:

1) Directed singing



2) Undirected singing



Songbirds learn to sing by imitating their tutor

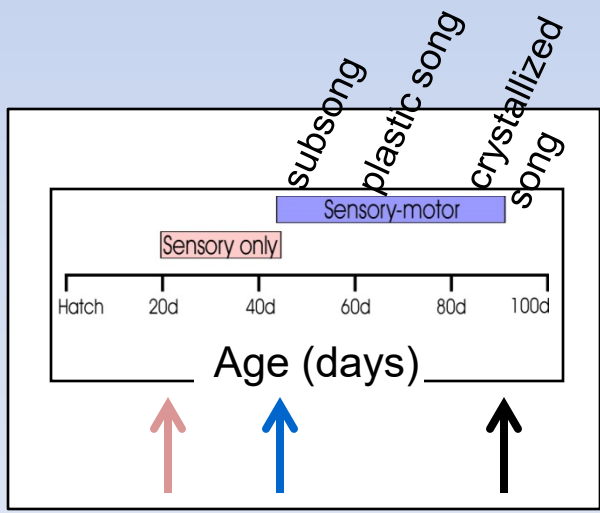
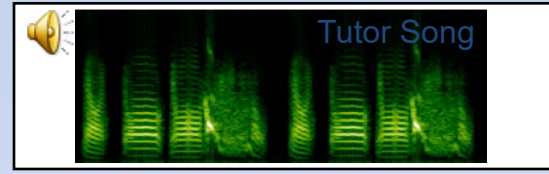
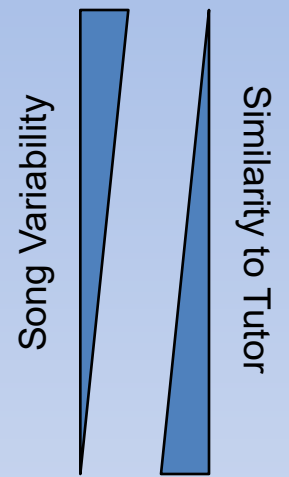
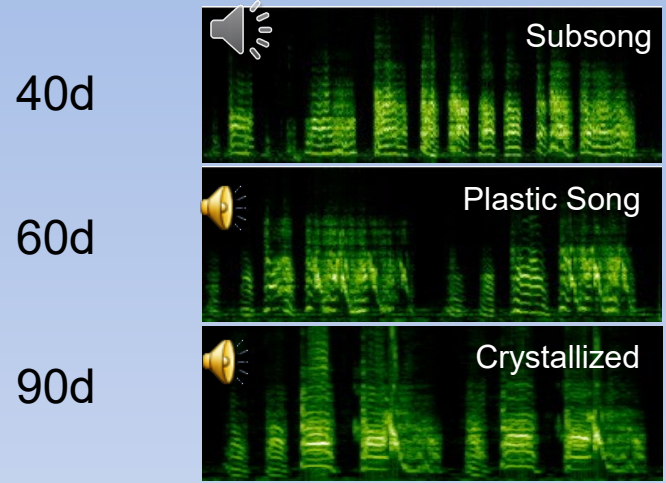

- The song is learned through **trail-and-error process**
- If you deafen a bird, the song does not evolve properly → the importance of auditory feedback

Reinforcement learning model for song acquisition - trial and error

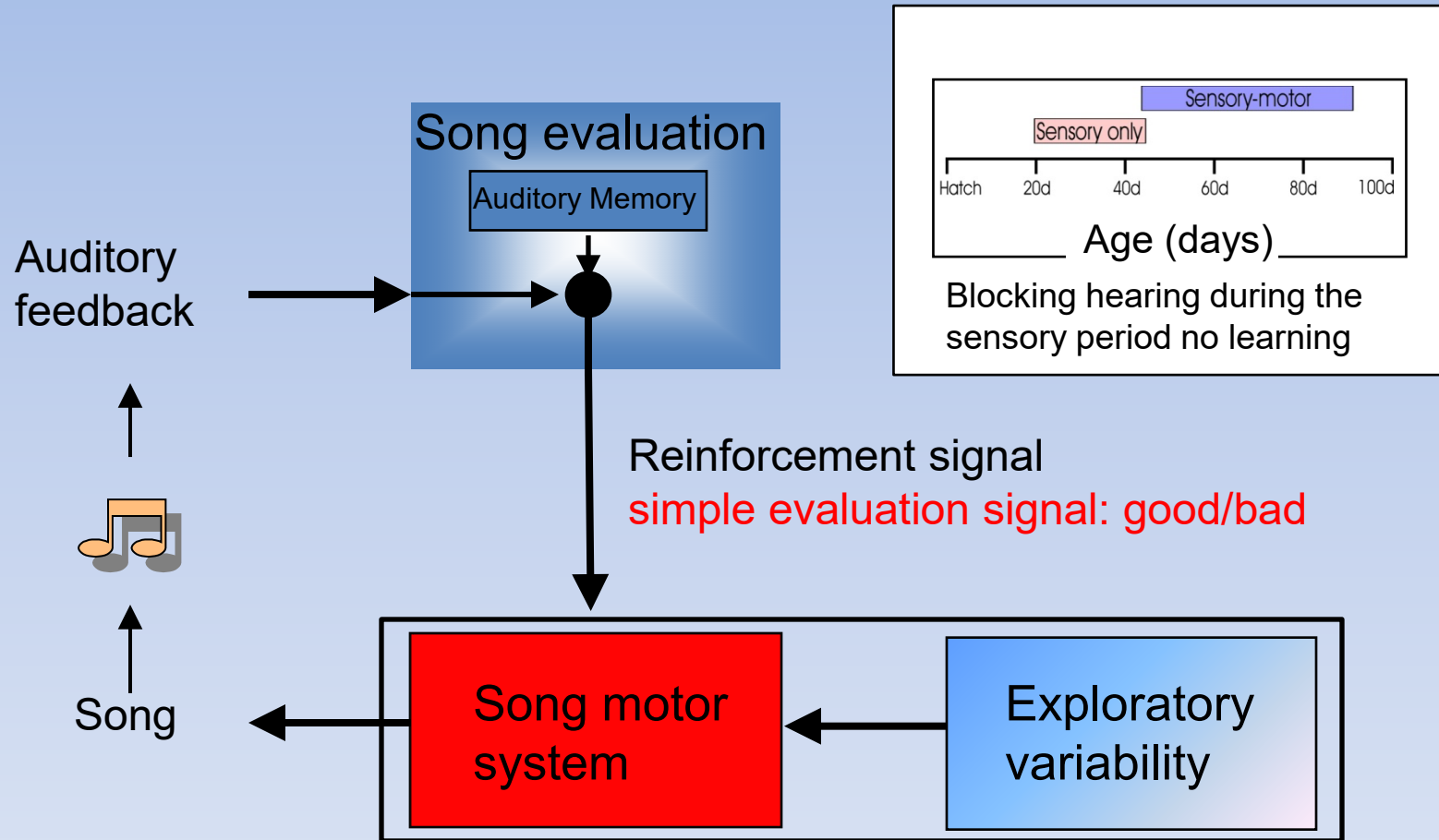

Konishi 1965; Marler 1970

By trial and error learning the bird can update his song to get a better match to his template – for this you need variations.

The brain areas that are devoted to the Song system

Many brain nuclei in avian telencephalon are derived from the pallial layer of embryos, which also gives rise to mammalian cortex.

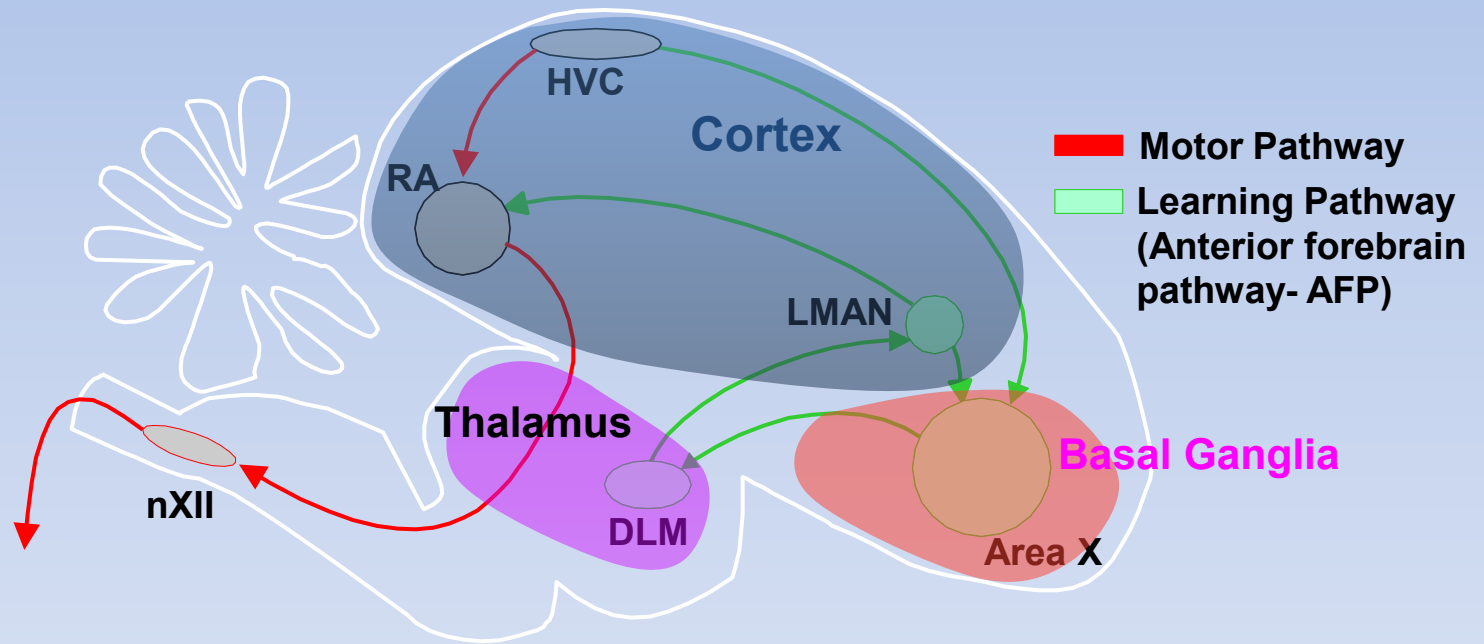

The motor pathway- if you lesion any of these song nuclei you disrupt the output of the song

The learning pathway is not necessary for adult song production, but is required for learning (Bottjer, 1984, Scharff and Nottebohm, 1991, Goldberg @ Fee , 2010)

No laminar structure found in avian brain Instead there are Nuclei

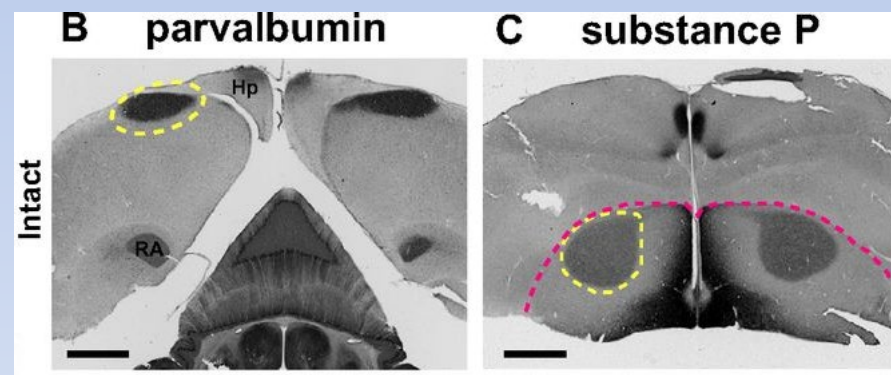
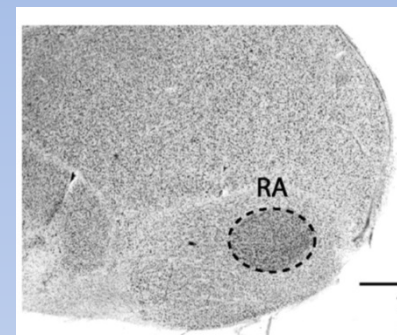
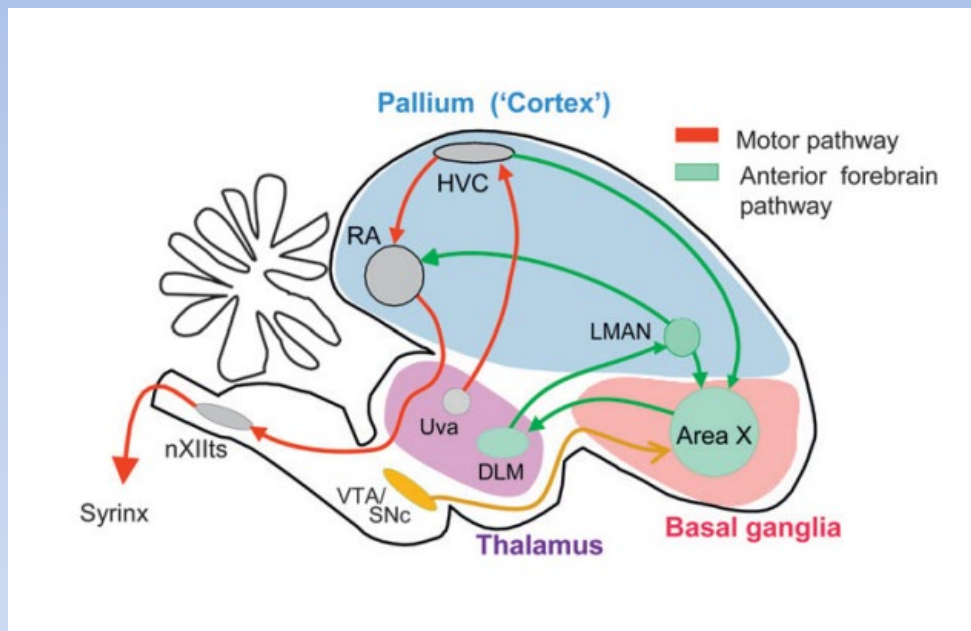

Birds lack a corpus callosum; instead, connectivity between the two hemispheres is facilitated through the brainstem.

What is clearly missing in these coronal sections?

Motor pathway

- **HVC** (**high vocal center**, originally was named hyperstriatum ventrale, pars caudalis (HVCc))
- **RA** primary motor “cortex” layer 5
- brainstem motor areas
 - Muscles of the syrinx
 - respiratory muscles

The brain areas that are involved in song production have been outlined mostly by **Frenando Nottebohm's** lab

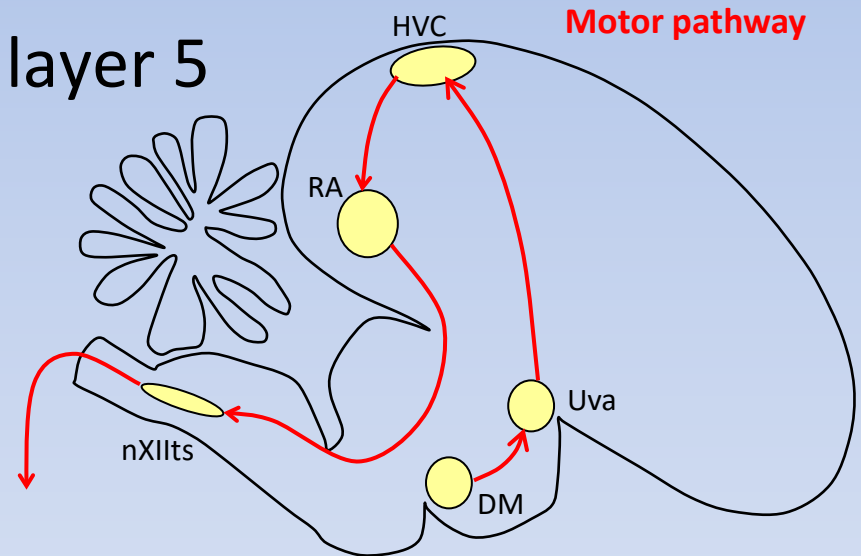

Nottebohm et al., (*J Comp Neurol*, 1976)

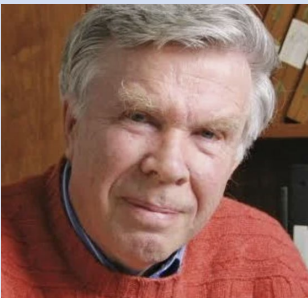

In **1980s** finally convinced the community present of **adult neurogenesis** in canaries

- **Question:**

How do these circuits work to produce a song?

Record from brain areas and see what are the firing patterns of these neurons during singing.

Multi unit recording in HVC showed increase activity during singing

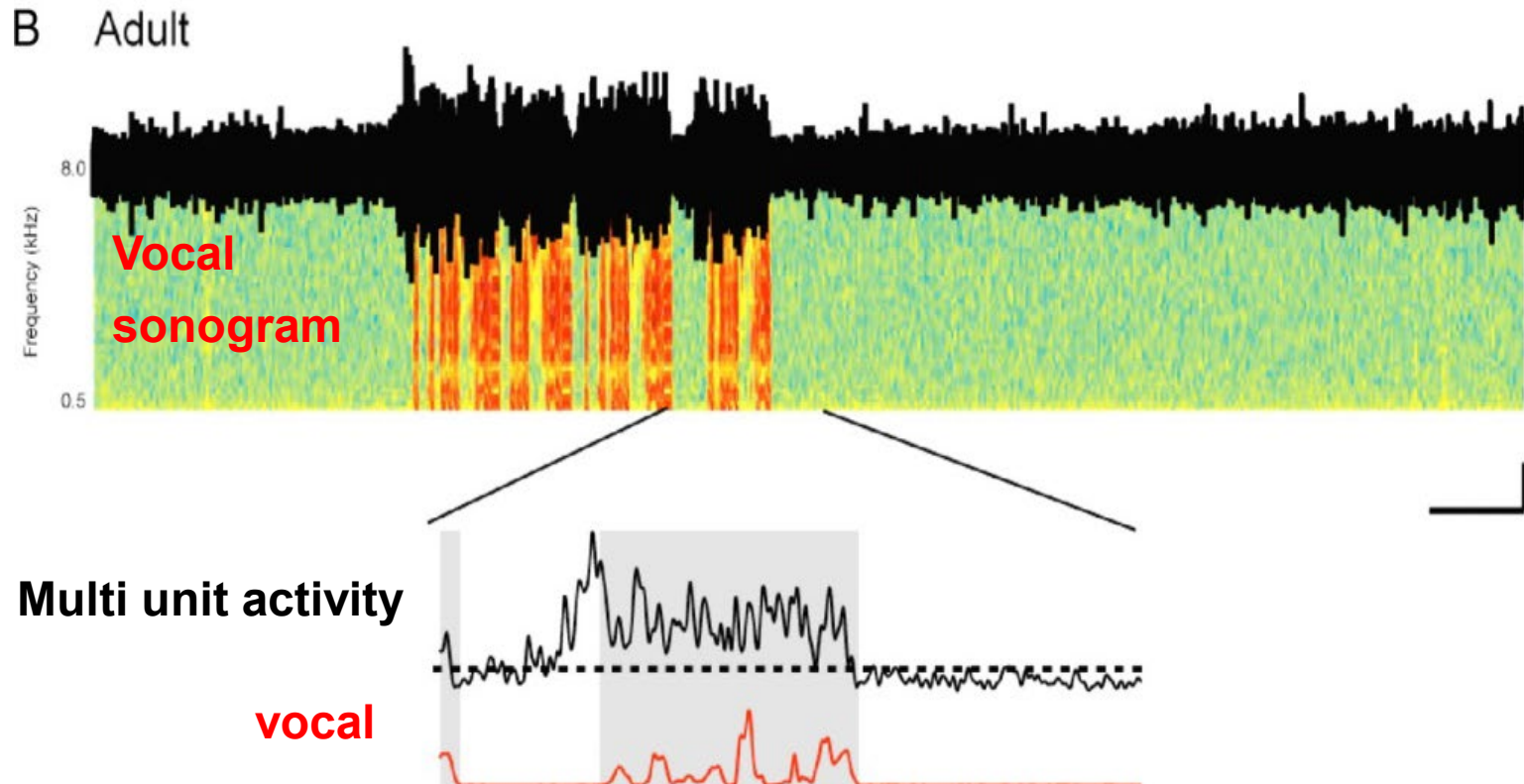

Recording from HVC showed a massive neuronal signal that was throughout the song- that was not well correlated with the song pattern.

Neuroanatomy suggested that there are three types of neurons
→ maybe there are also 3 distinct neuronal responses???

Three types of neurons in HVC:

- 1) HVC-RA projecting neurons
- 2) HVC-X projecting neurons
- 3) interneurons

The need for identify the neurons you record from and their projection site

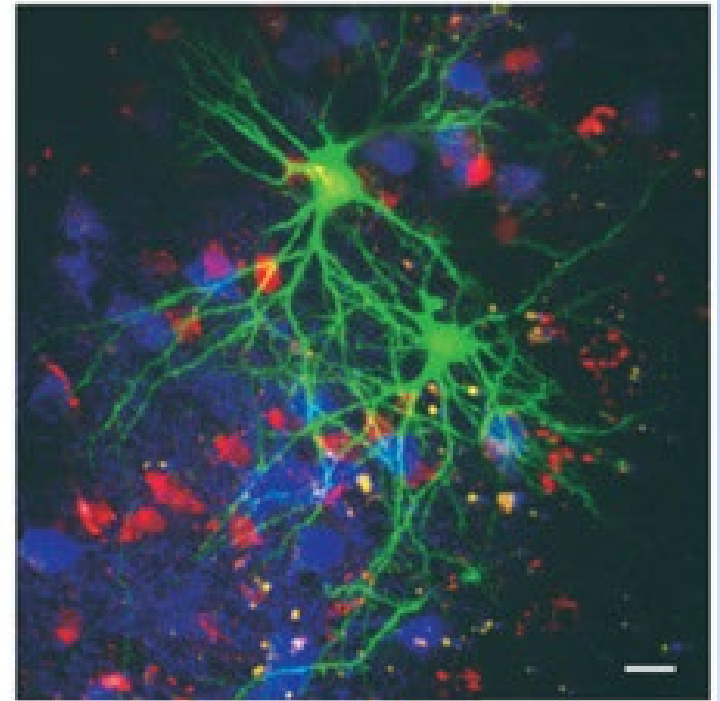
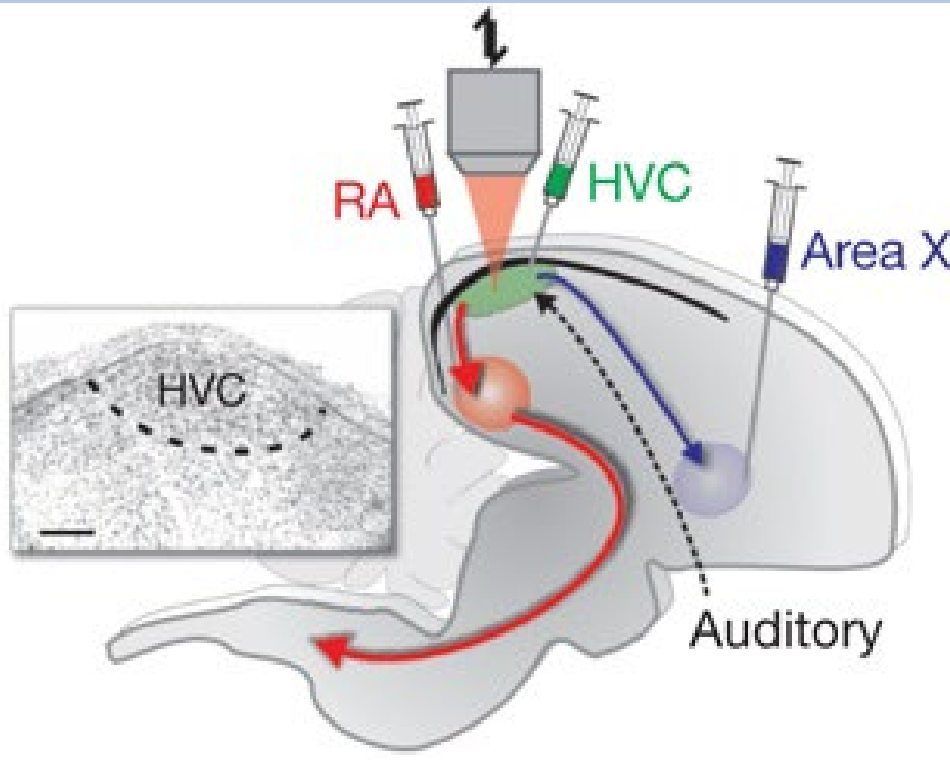

How to identify neurons you are recording from?

- Antidromic electrical stimulation

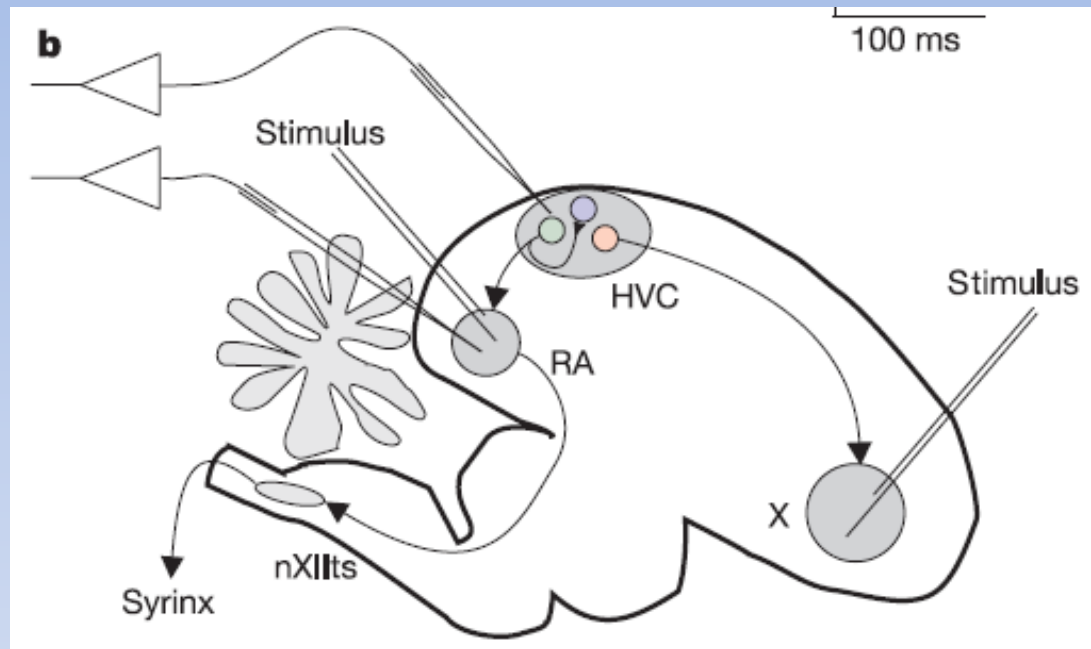

Hahnloser et al. (*Nature*, 2002)

Using antidromic stimulation to identify cell types within HVC

the stimulation induce current in the axon terminals, around the area of the stimulation, this results in AP that is generate and propagate on the axon backwards towards the soma.

Stimulating electrode

Recording electrode

HVC

RA

Axon terminals

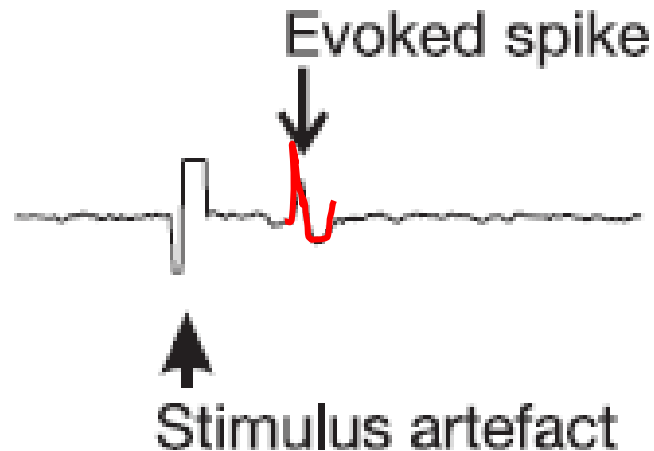

The recordings from the cell soma will first show artifact created by the stimulus- followed by an interval → the spike traveling time on the axon → and then the evoked spike

But this is not enough!
How do we differentiate
between these two options?

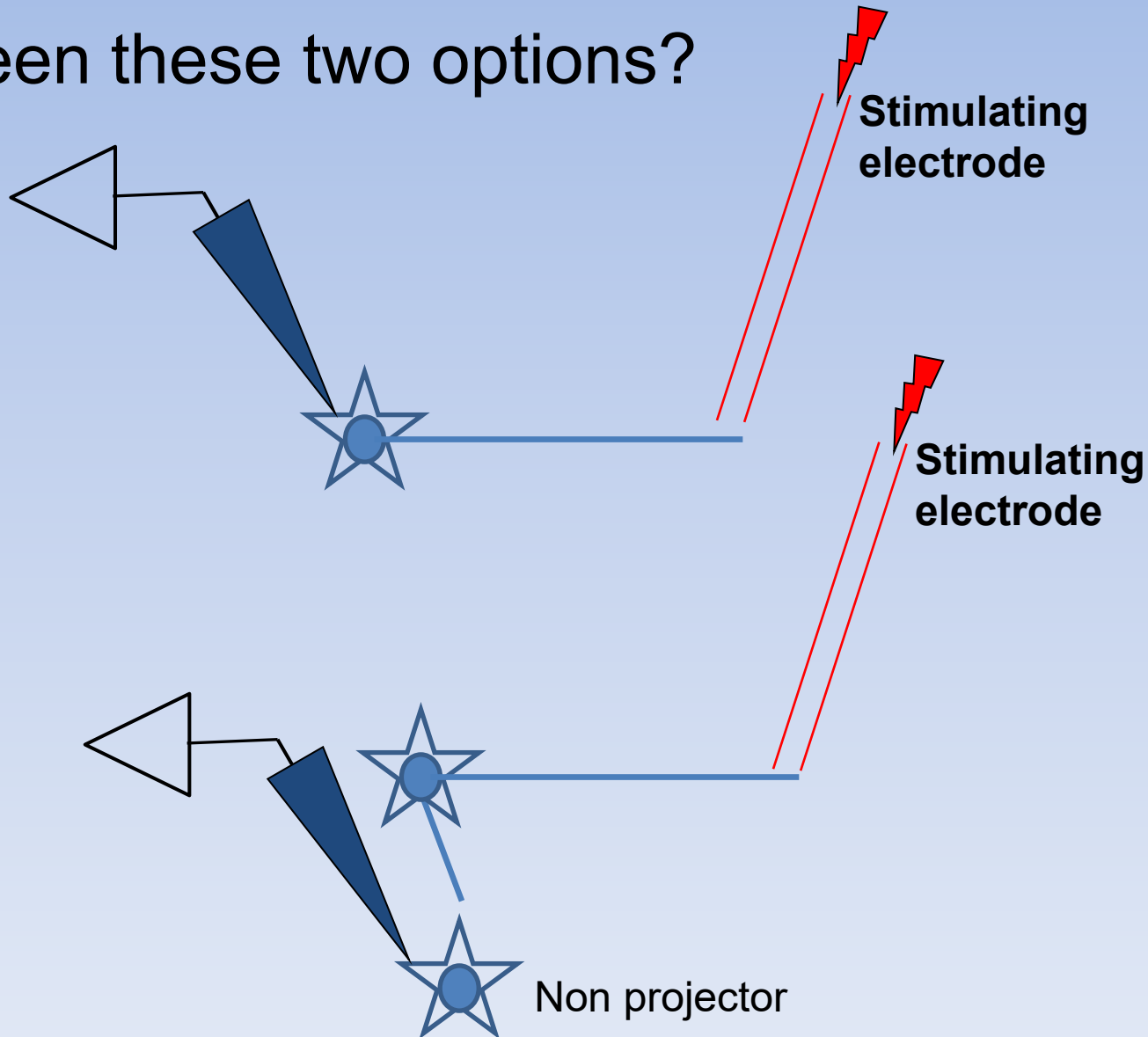

Collision test – the use of refractory period

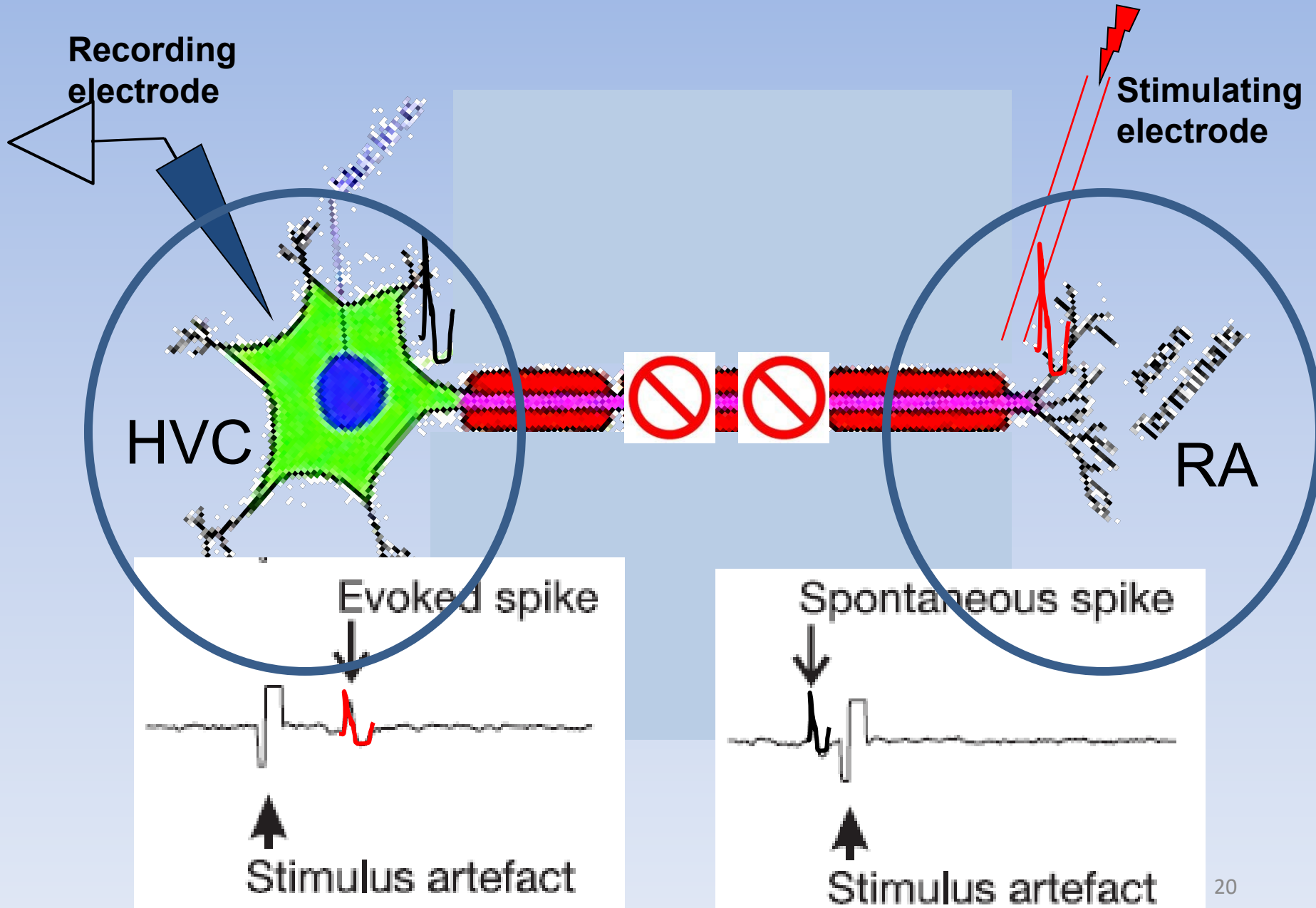

a

Detection of antidromic spike

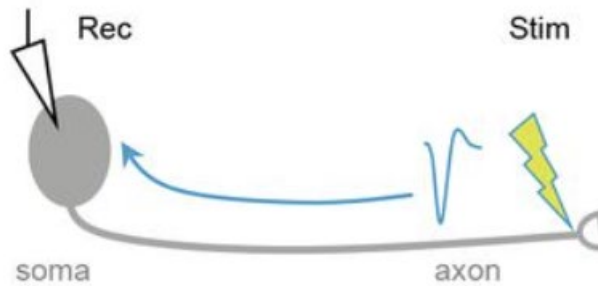
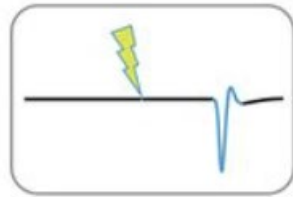

Spike collision test (*success*)

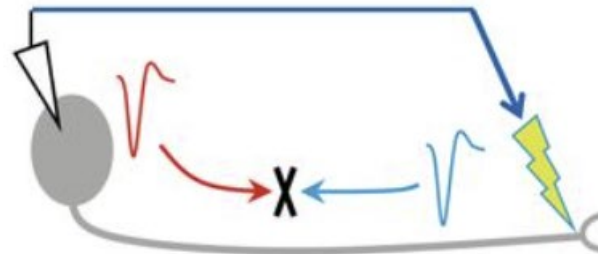
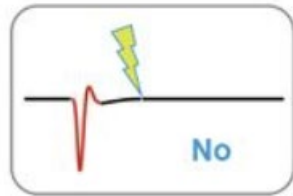

Spike collision test (*failure*)

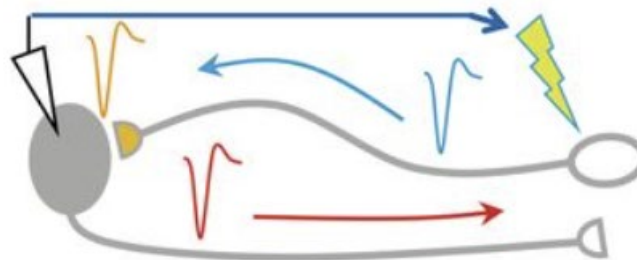
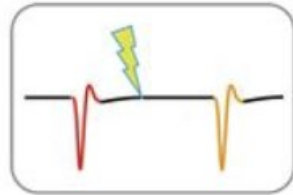

Antidromic (evoked) spike



Synaptic spike



Trigger (spontaneous) spike

How to identify neurons you are recording from?

- Antidromic stimulation (electrical or optogenetic)

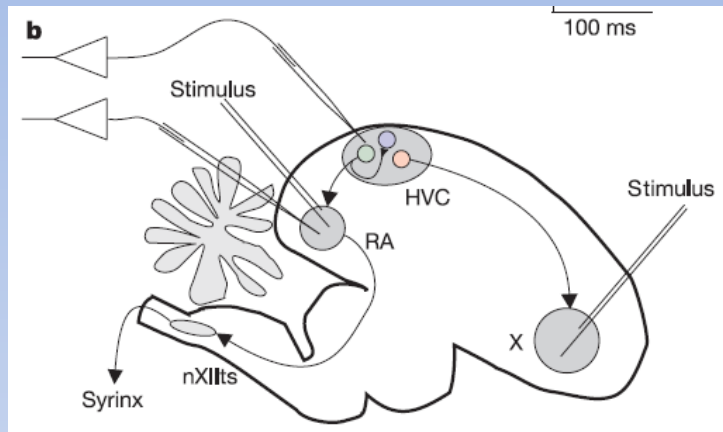

Hahnloser et al. (*Nature*, 2002)



- Labeling (genetically or injections)

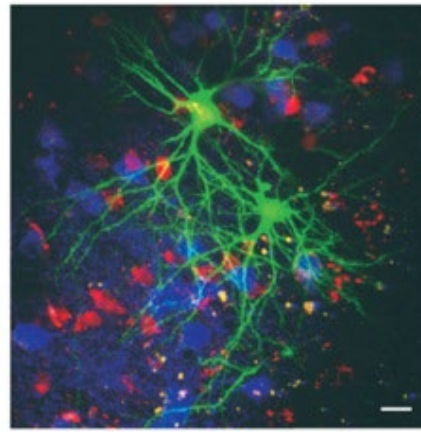
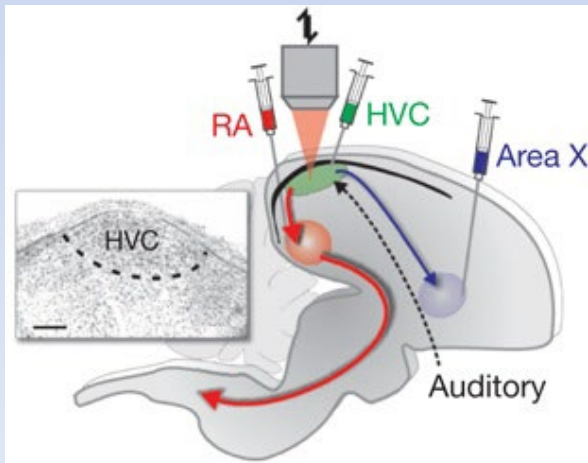

Using antidromic stimulation to identify cell types within HVC

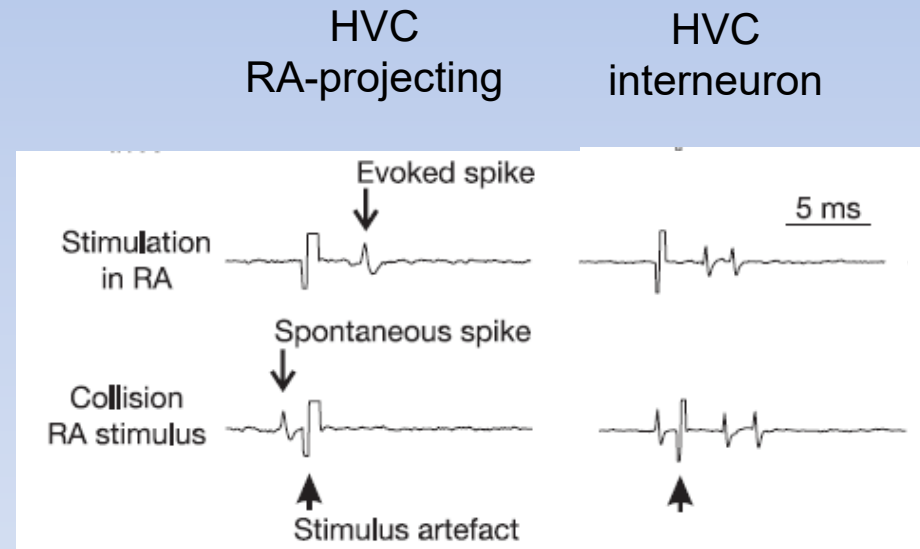
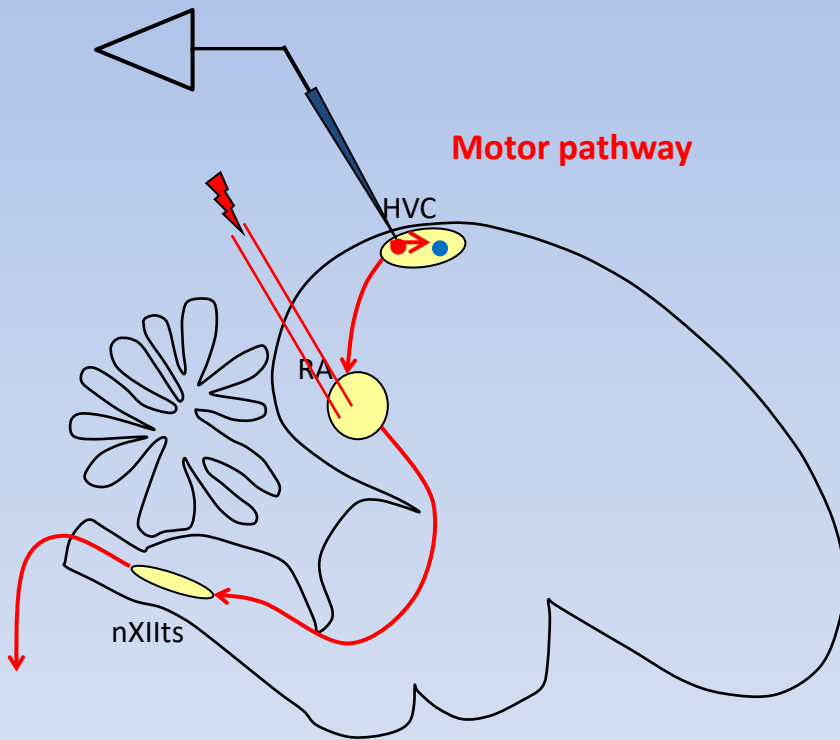

Hahnloser et al. (*Nature*, 2002)

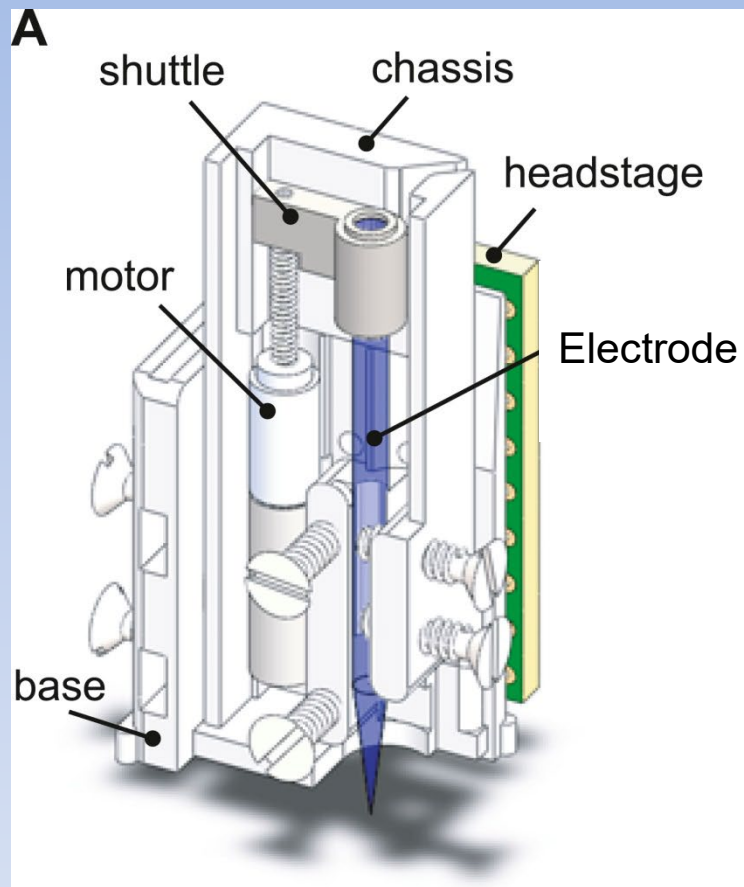

Activity of HVC-RA neurons during singing

because the behavioral is so stereotyped you can align to the motif

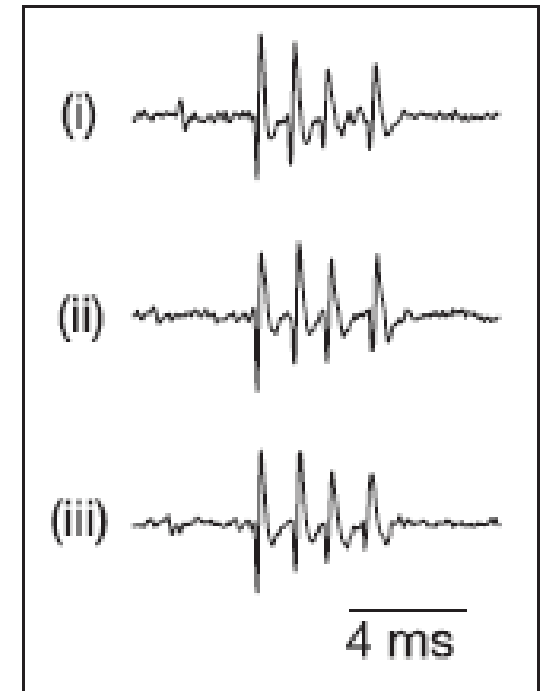
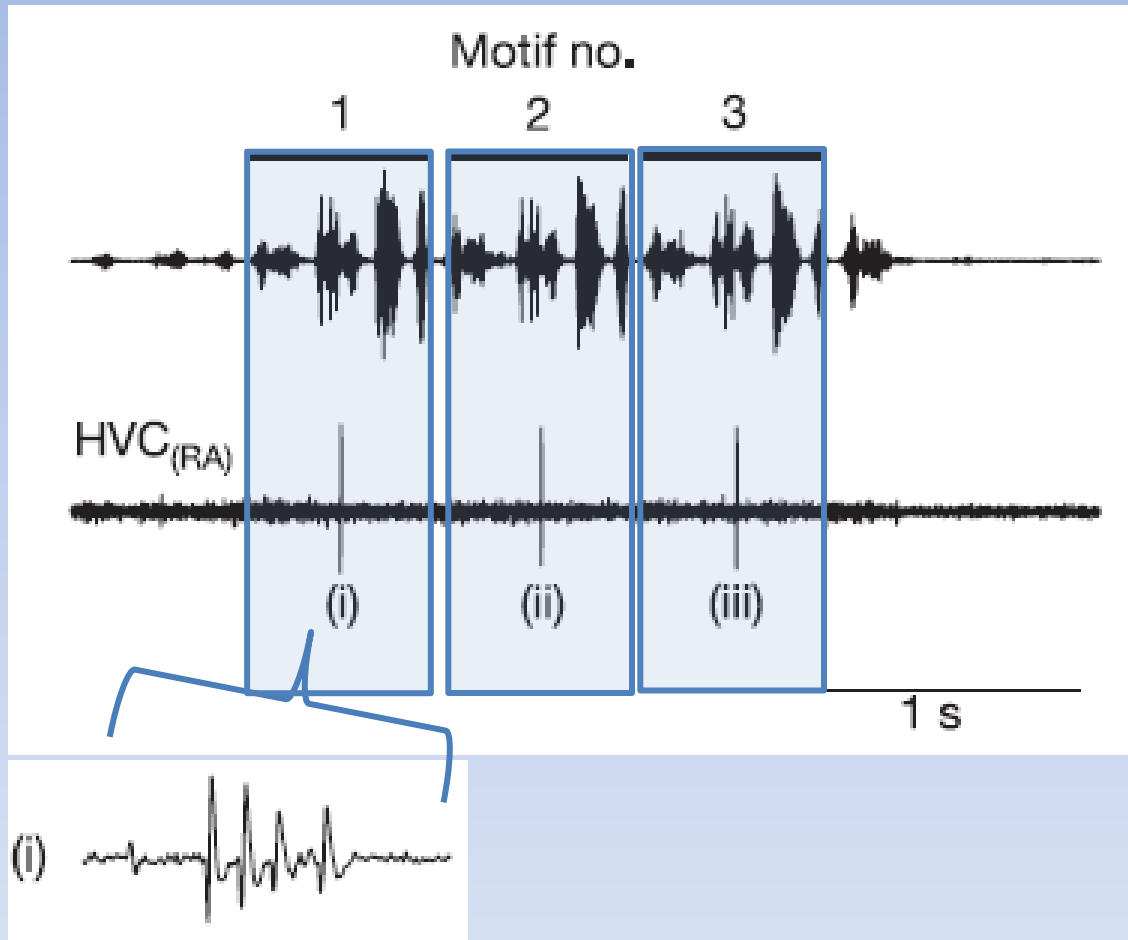

→ burst of spikes (4-5 spikes) that take ~10 ms long!

spars activity and very precise.

raster plot

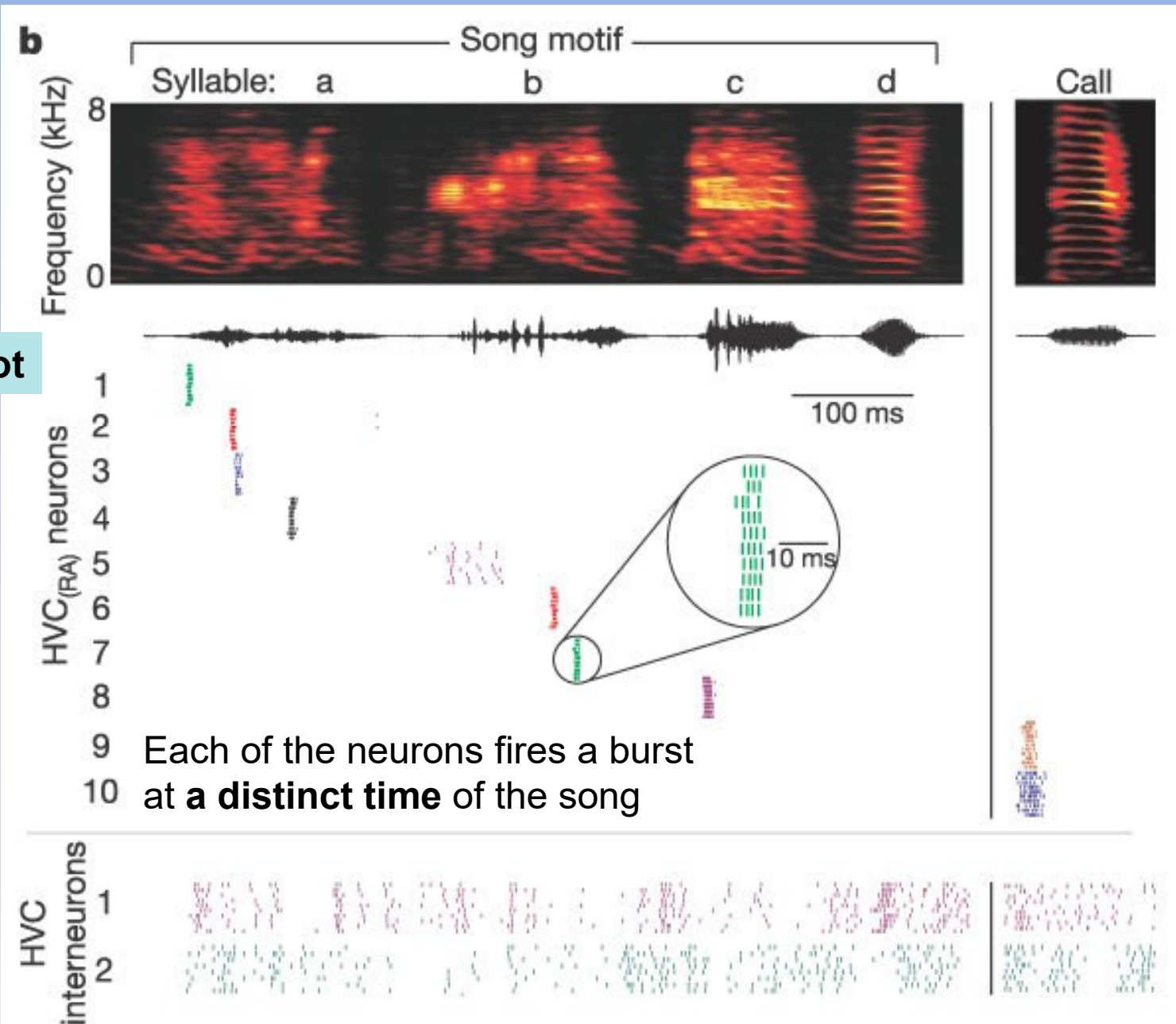

Each of the neurons fires a burst at a **distinct time** of the song

This suggest a *sparse* sequence of activity that propagates through the song.

Hahnloser et al. (*Nature*, 2002)

HVC bursting produces continuous coverage of time in the song

The population of HVC projection neurons is *continuously active* during singing

These extremely sparse and precise patterns of activity suggest the entire ensemble of HVC_{RA} neurons could function to specify the timing of syllables, notes, and even the intervening silent “gaps.”

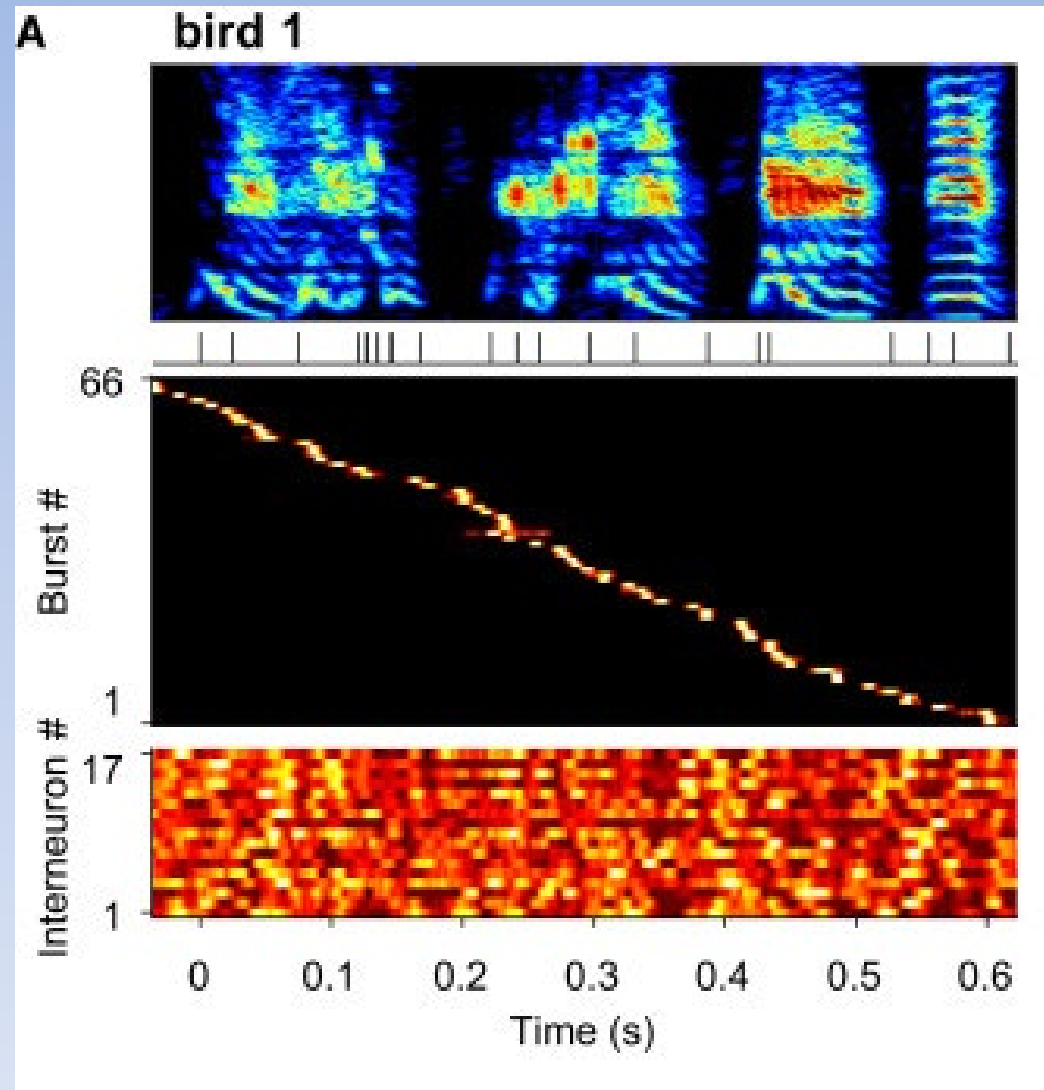

Rhythmic Continuous-Time Coding in the Songbird Analog of Vocal Motor Cortex

[Galen F.Lynch¹⁴Tatsuo S.Okubo¹⁴AlexanderHanuschkin²³Richard H.R.Hahnloser²³Michale S.Fee¹](#)

The sparse activity of HVC neurons and its location makes it perfect for two-photon calcium imaging

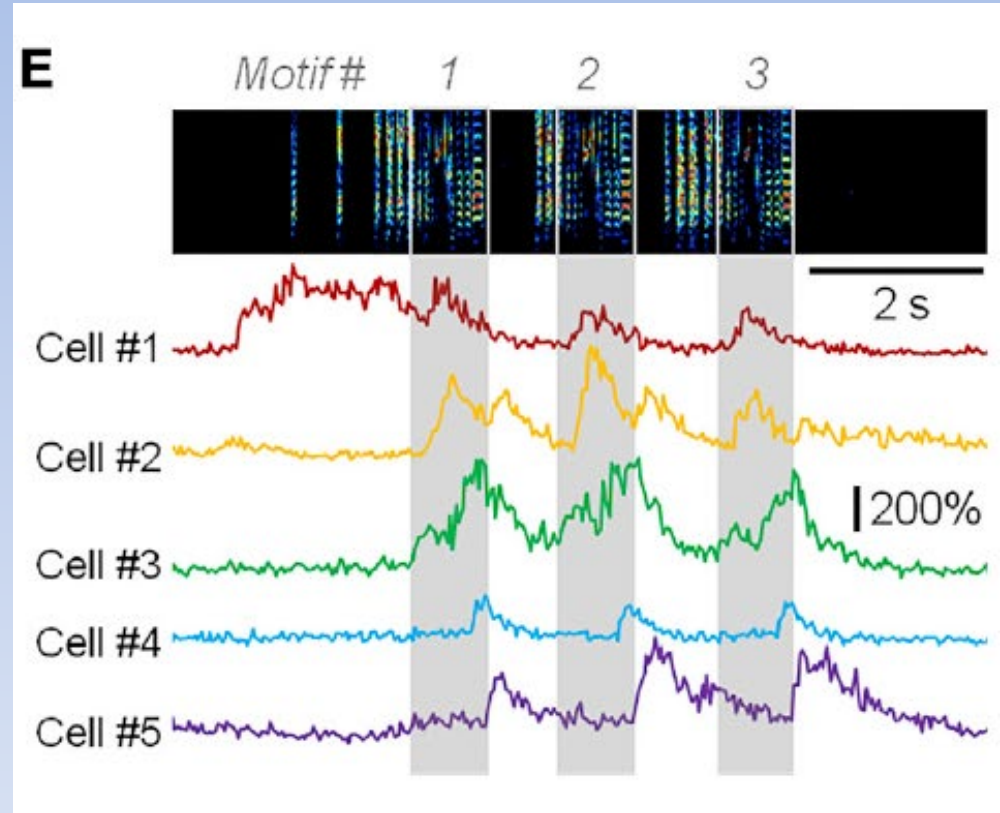
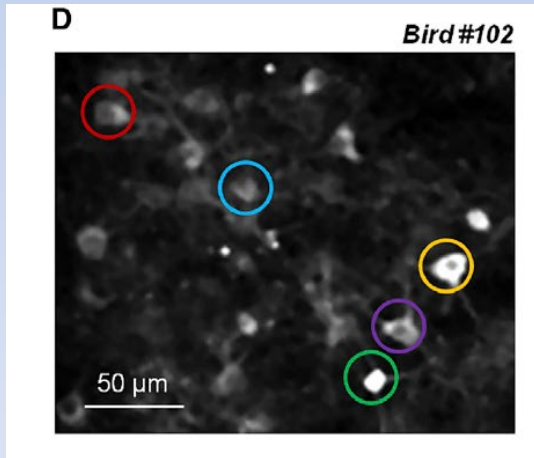
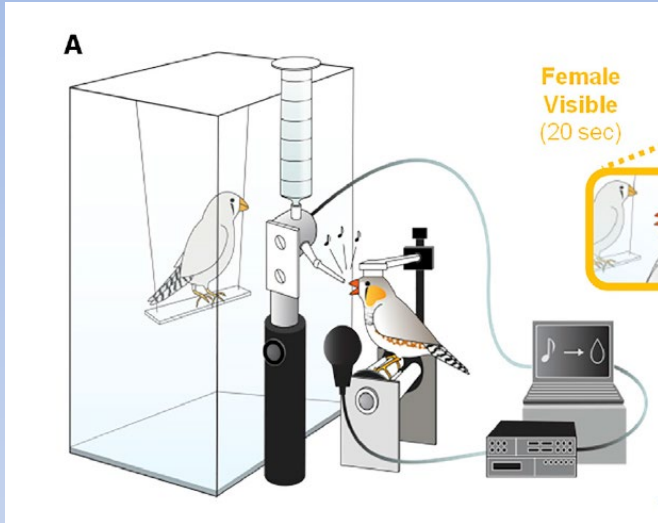
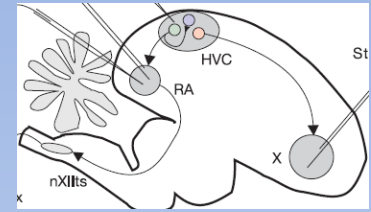

Population-Level Representation of a Temporal Sequence Underlying Song production in the Zebra Finch. 2016, Neuron

Michel A. Picardo, Josh Merel, ..., Eftychios A. Pnevmatikakis, Liam Paninski, Michael A. Long

Motif no.

1

2

3

The song



Recordings from RA neuron during the song

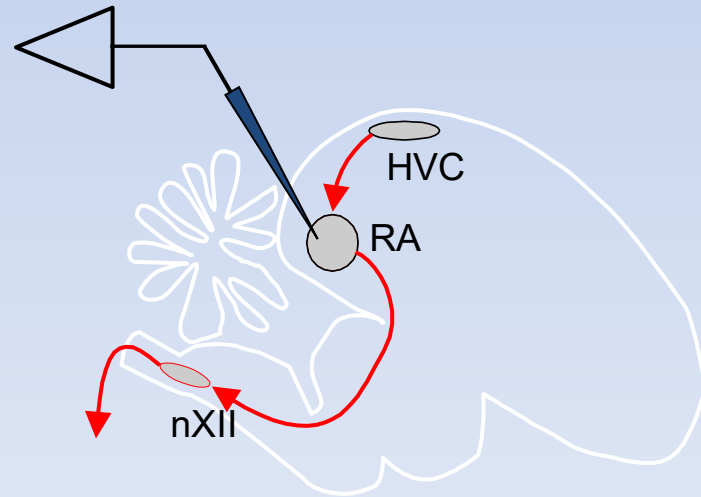
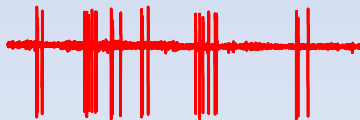
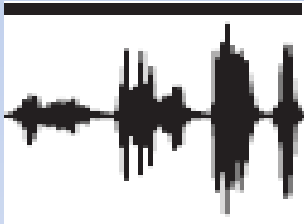
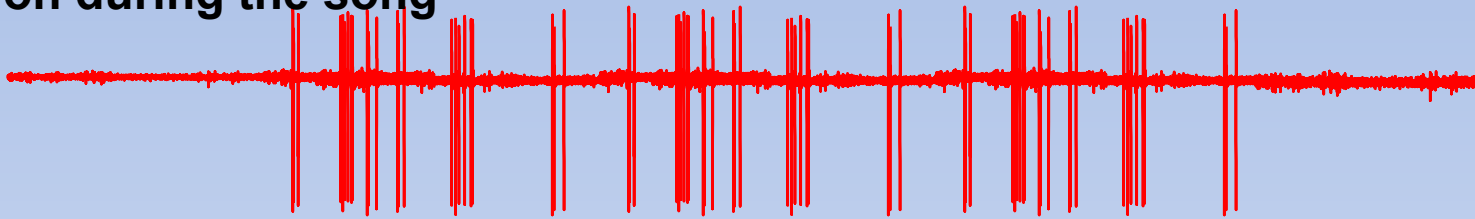

RA activity during singing

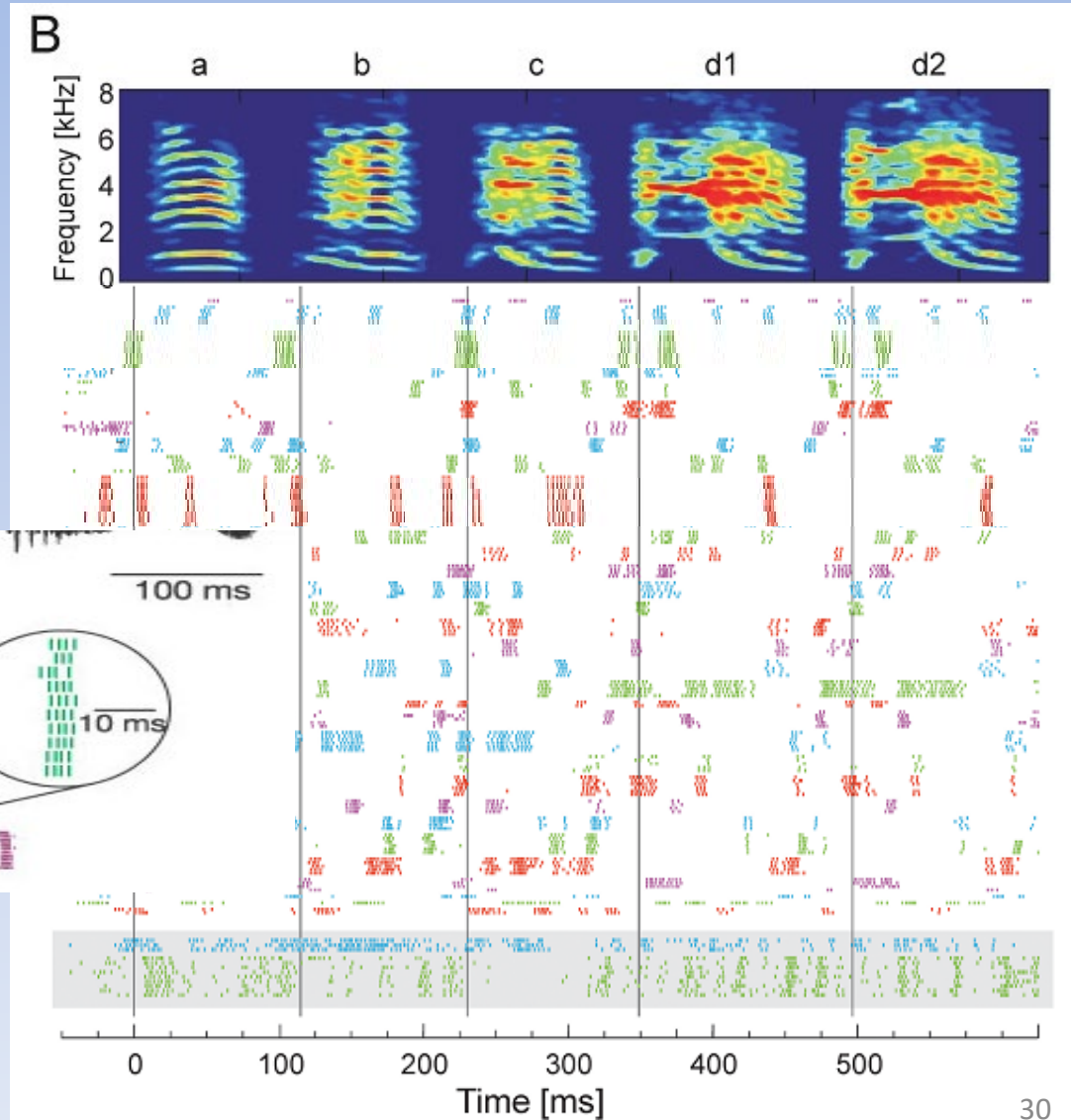
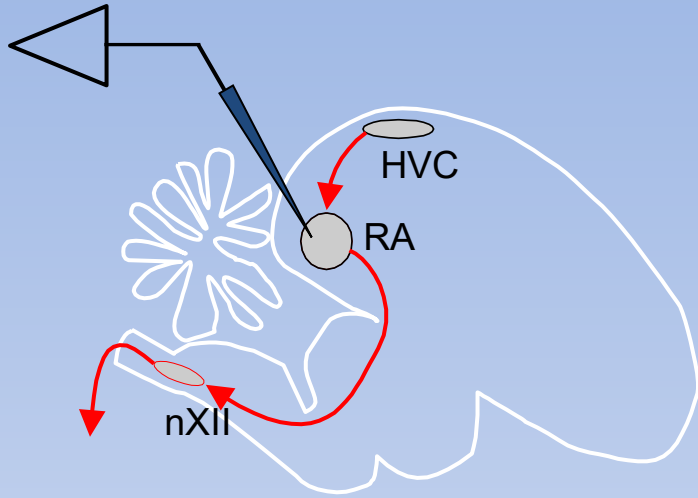

HVC-RA neurons

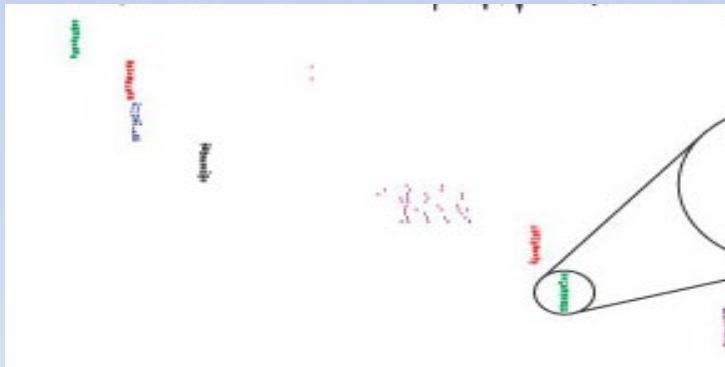

Leonardo & Fee (*J Neurosci*, 2005)

Simple sequence generation circuit

Bursting activity propagates through a chain of synaptically connected HVC_{RA} neurons (like falling dominoes/like a clock), creating a timing signal that spans the entire motif.

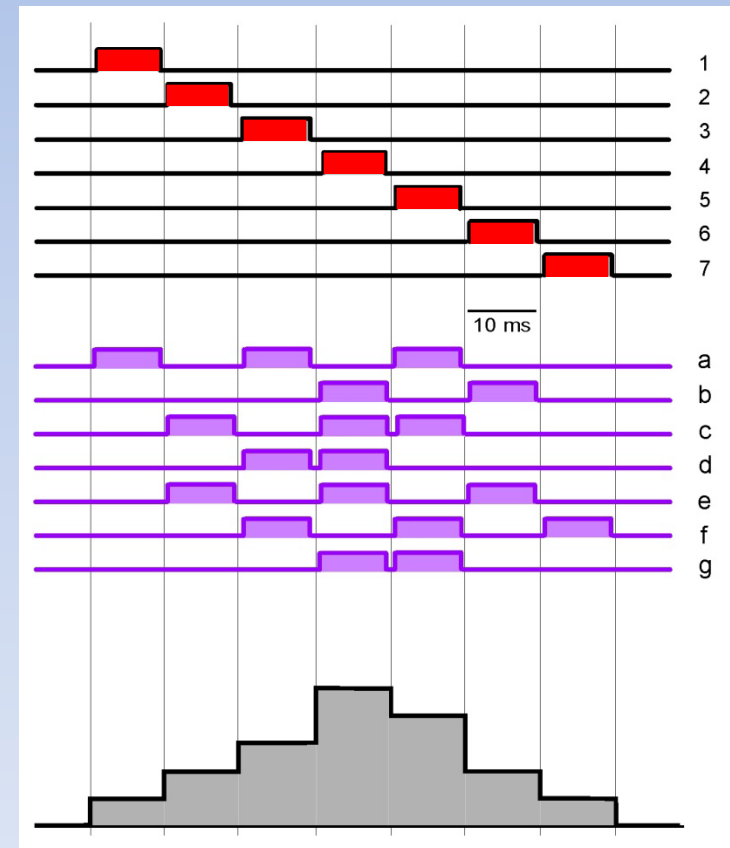
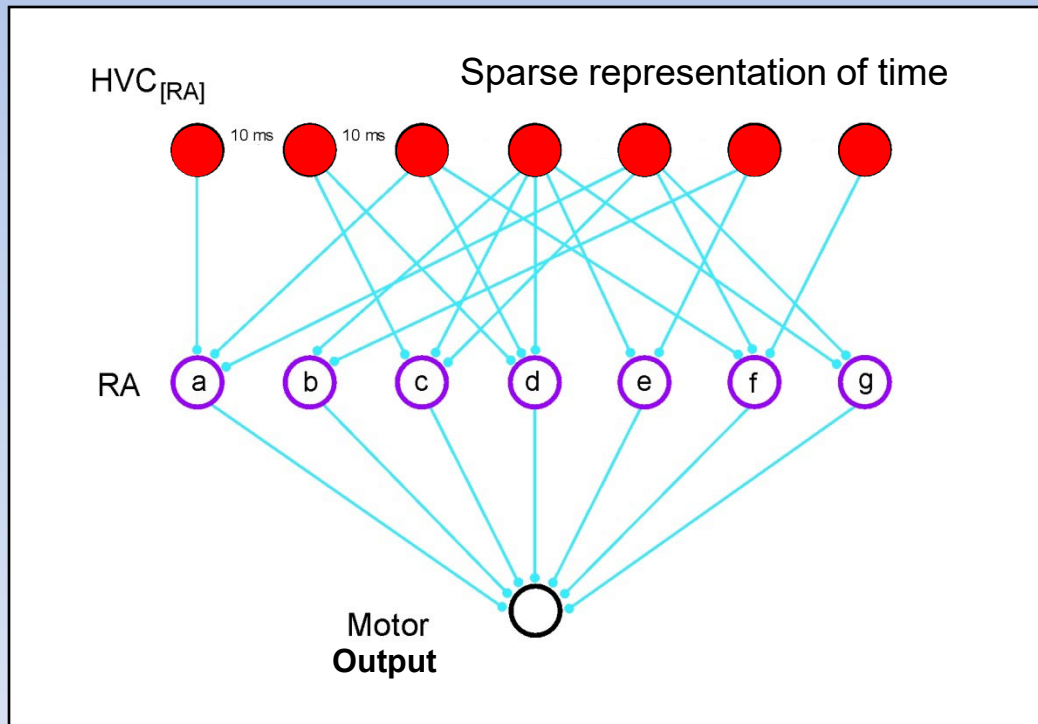

Simple sequence generation circuit

The output of HVC cell goes to more than one RA neuron → **each RA neuro will be activated more than just once in a motif.** The summation of RA neurons converge onto to the mn in the brainstem.

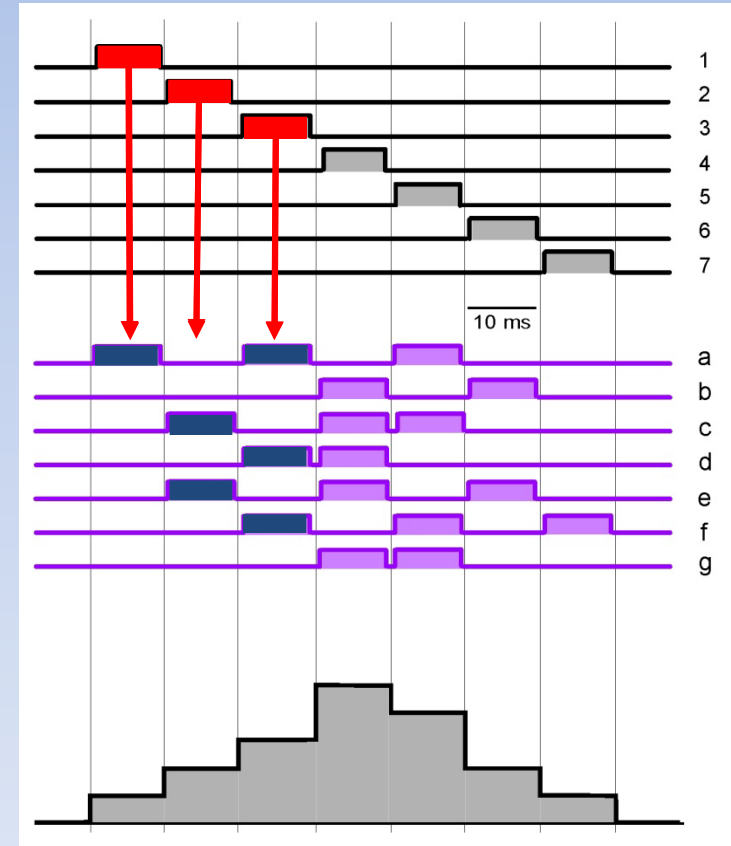
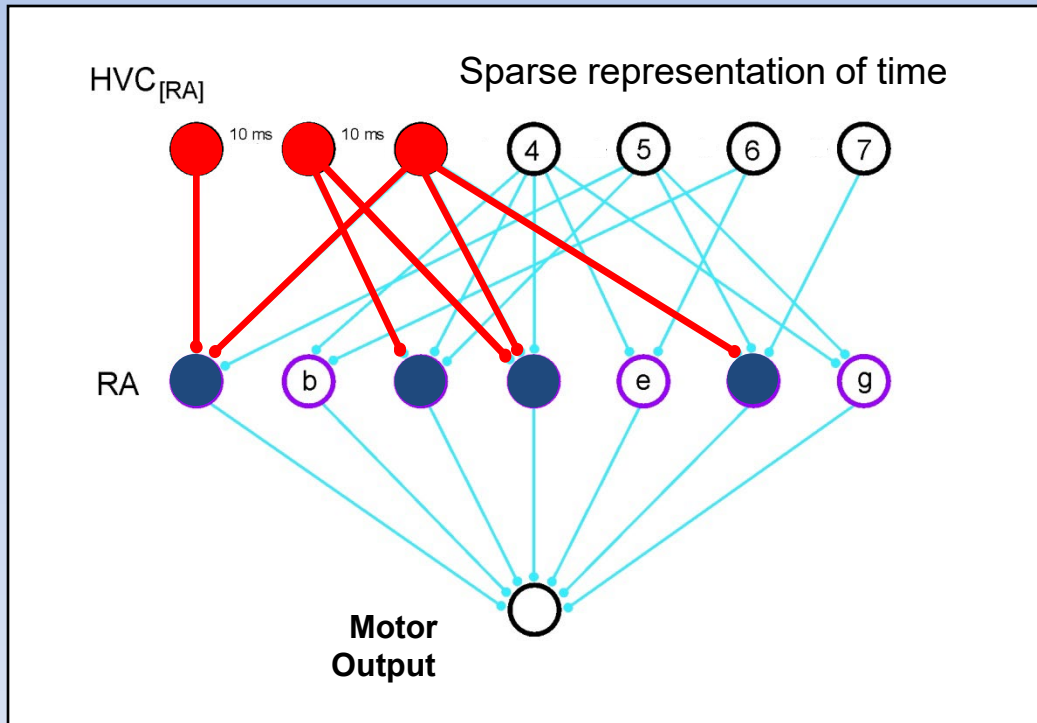

Part 1: Summary

- HVC exhibits sparse bursts during singing.
- RA transforms the sparse code into multiple bursts which then drive motoneurons.
- BUT: Where are these patterns of activity coming from? What is driving HVC to fire at a particular moment?

(b) Dynamics within HVC

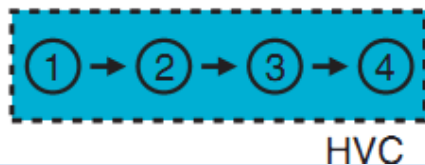

(c) Dynamics Upstream

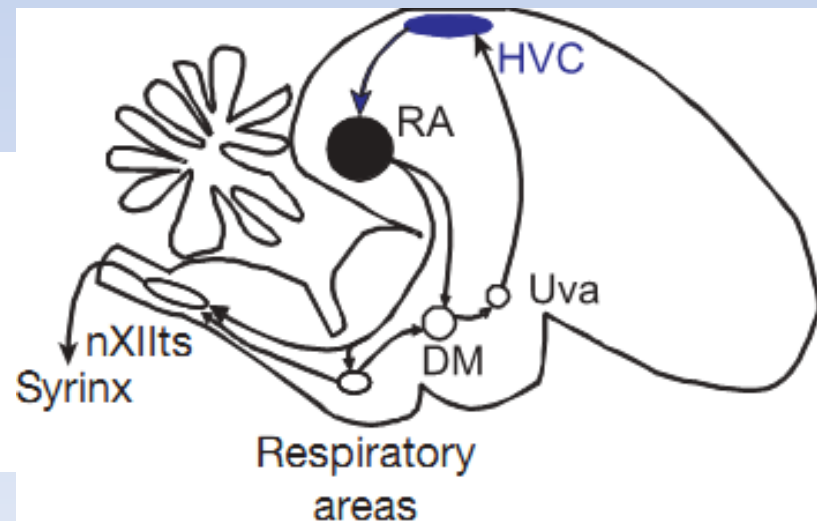
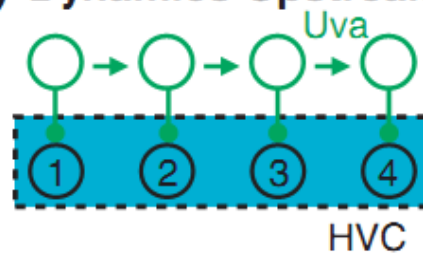

15 min break

Maybe its within HVC?
one chain model for all song dynamics

A continuous-time model

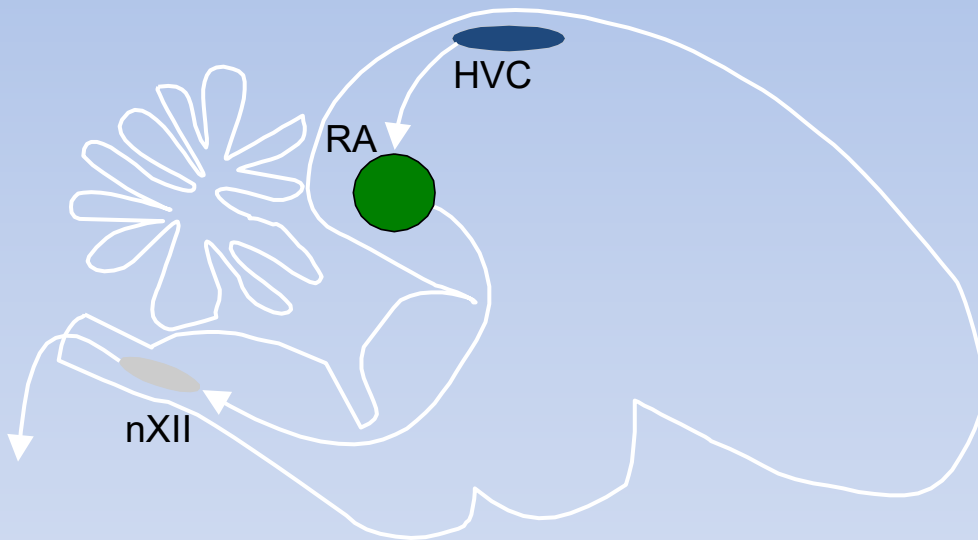

HVC

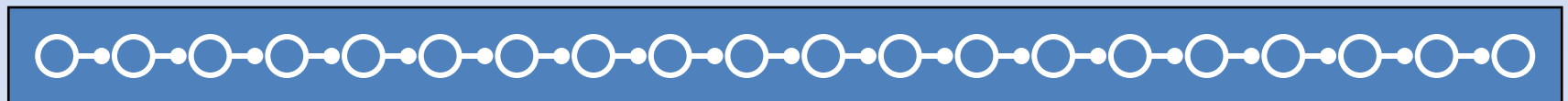

Li and Greenside, 2006
Jin et al, 2007
Long, Jin, Fee, 2010

OR: The chain might have links outside of HVC

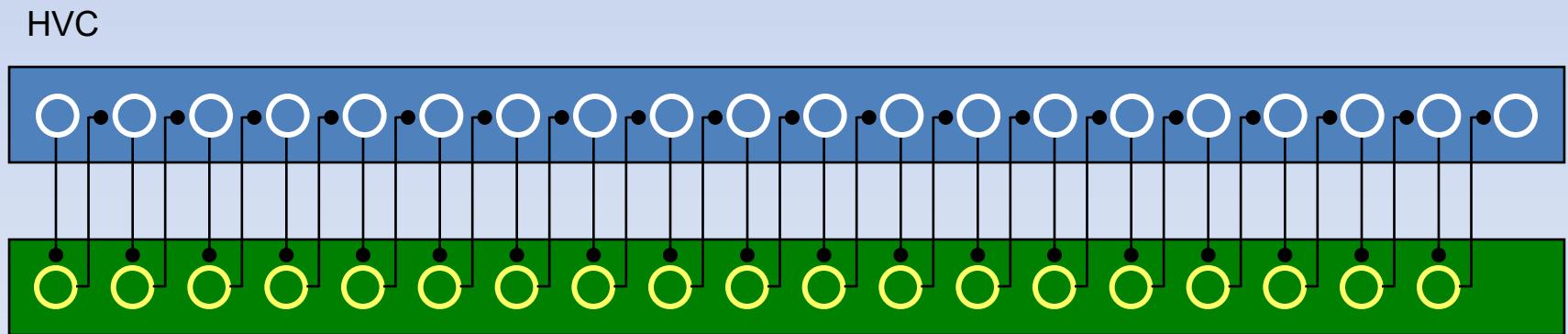
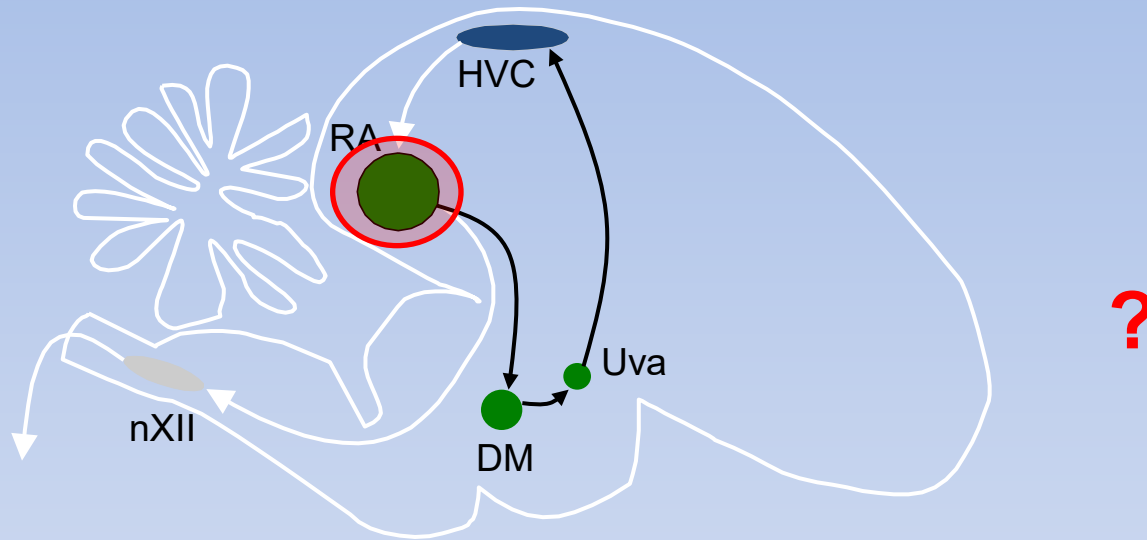

RA / DM / Uva

Hamaguchi, Tanaka, Mooney, 2016

What and where is the mechanism that determines tempo? Are the slow dynamics generated within HVC?

If song tempo is determined by the activity within the HVC local network, then song should slow as HVC is cooled.

Theoretical predictions

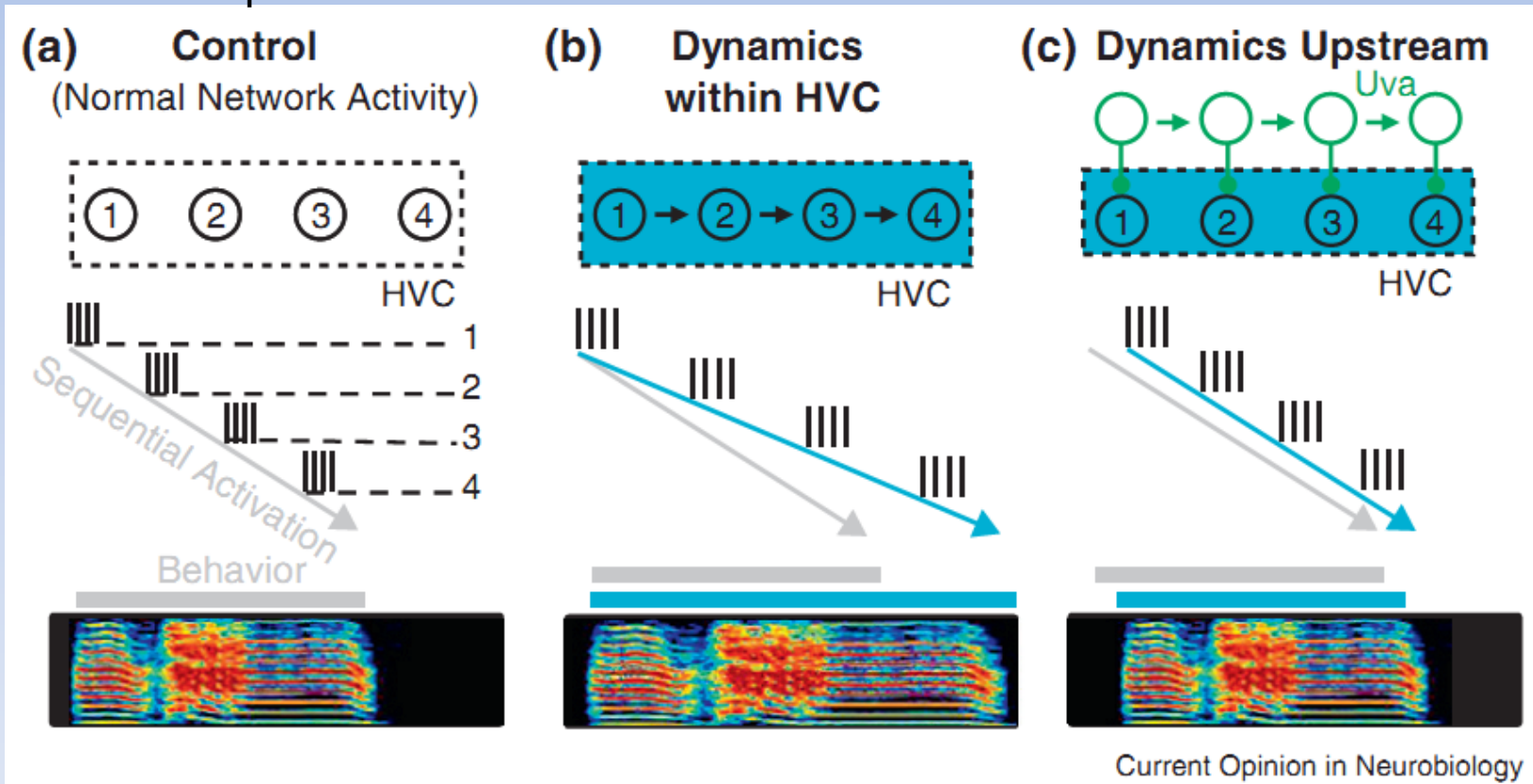

Local manipulation of brain temperature

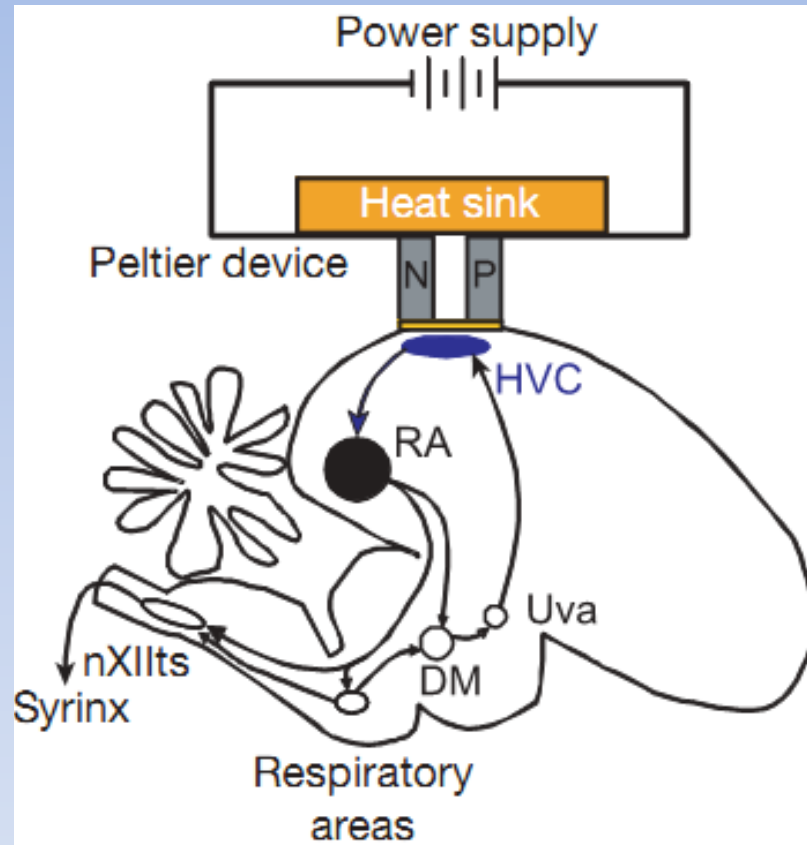

Long & Fee (*Nature*, 2008)

The temperature changes are very local, and rapid (within 10 seconds)

Cooling of HVC causes slowing of song...

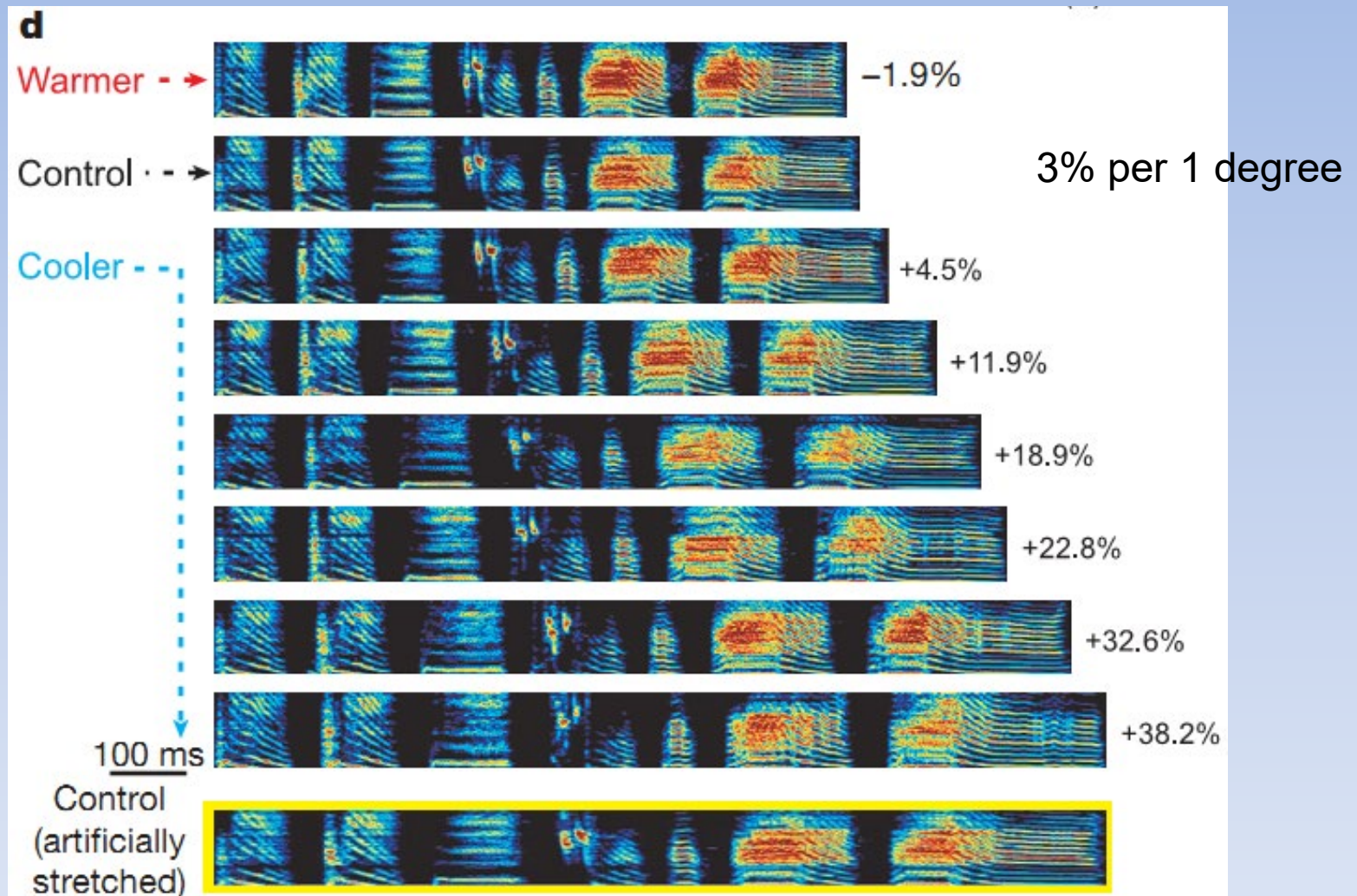

Stretching of song is highly uniform

Control: $T=40\text{ }^{\circ}\text{C}$

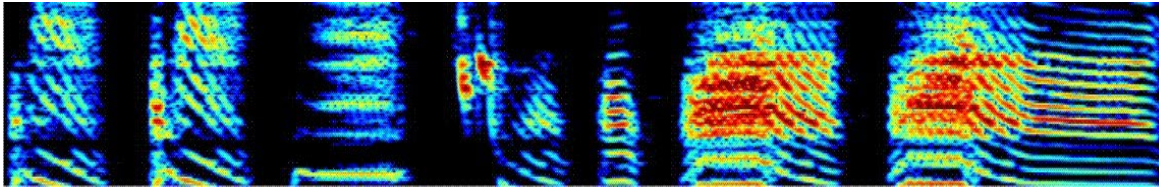

Cooled: $T=30\text{ }^{\circ}\text{C}$

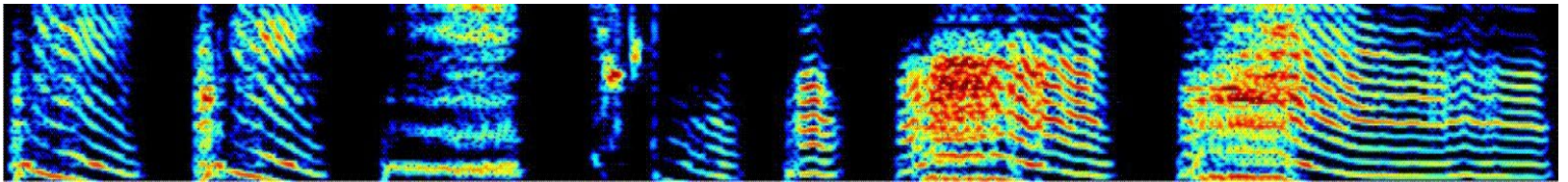

Control: image stretched

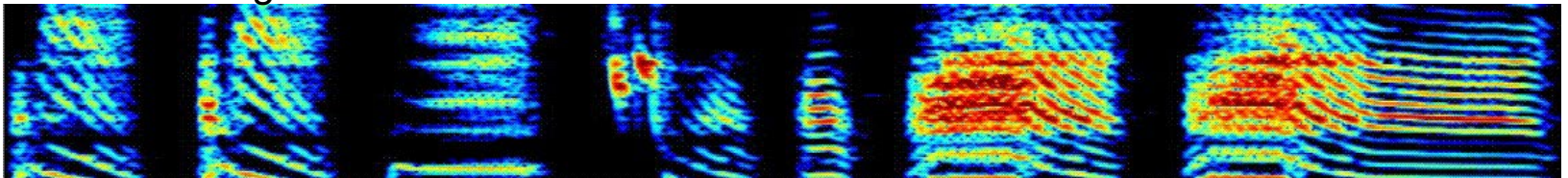

Cooling of HVC: Stretching of song is highly uniform!

song tempo slowed similarly across all timescales:

- 1) individual notes (~10 ms),
- 2) entire motif (~1s)
- 3) the silent gaps

3% per 1 degree

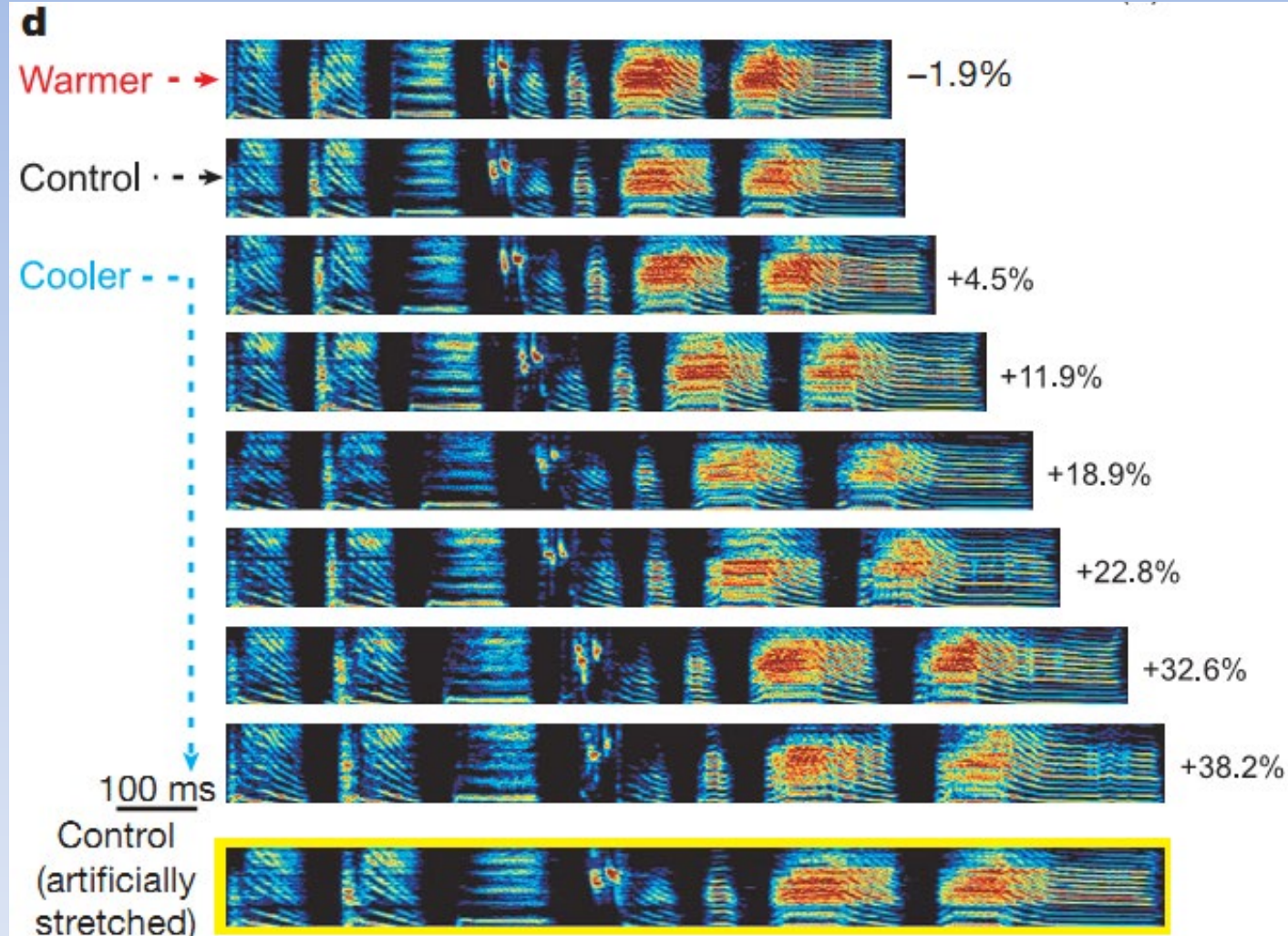

Long & Fee (*Nature*, 2008)

Cooling RA has no effect on song timing at any timescale, including song speed or the structure of the notes

Song timing is not controlled by dynamics within RA (from bilateral cooling in RA)

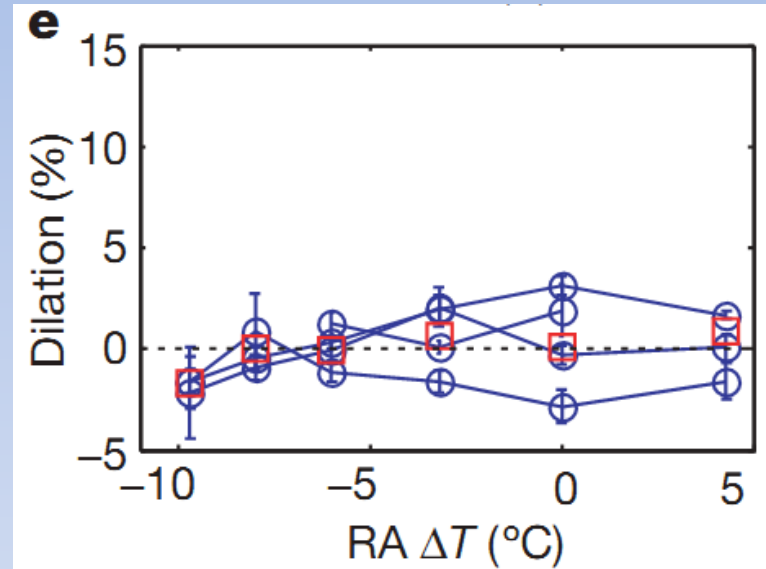
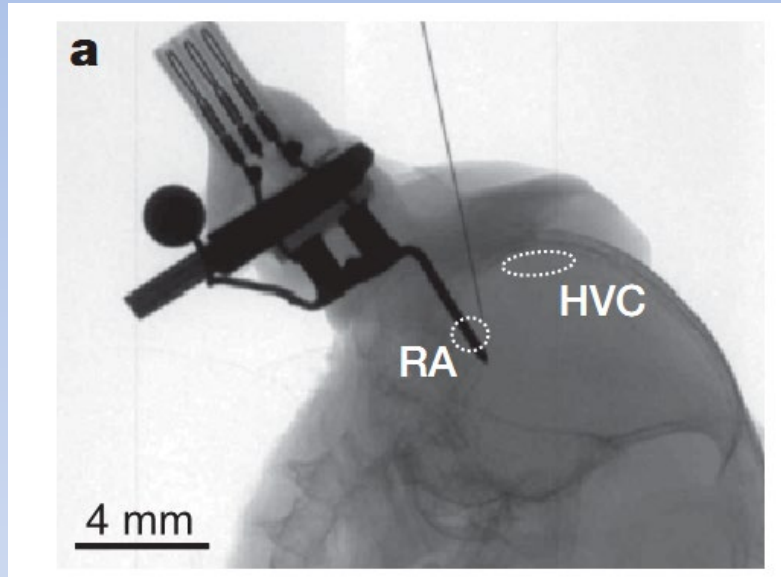

In contrast to the huge effect cooling in HVC

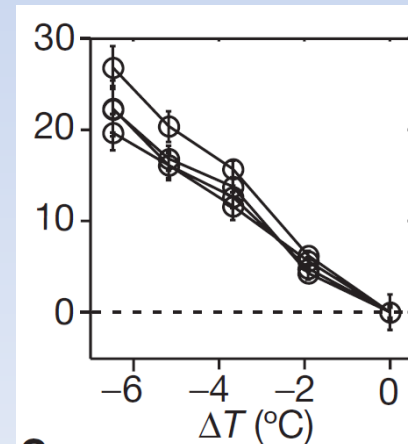

Are the **short dynamics (within one syllable)** generated within HVC? YES!!!

(b) Dynamics within HVC

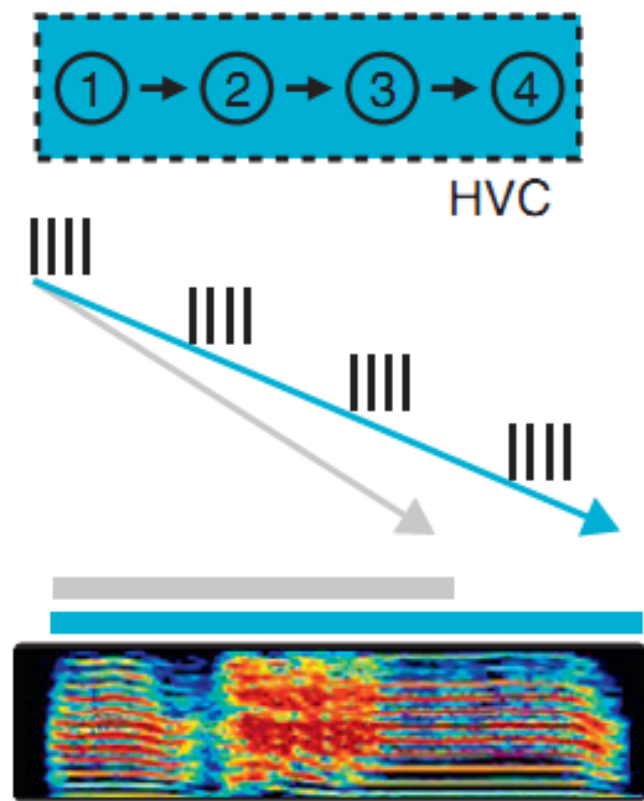

(c) Dynamics Upstream

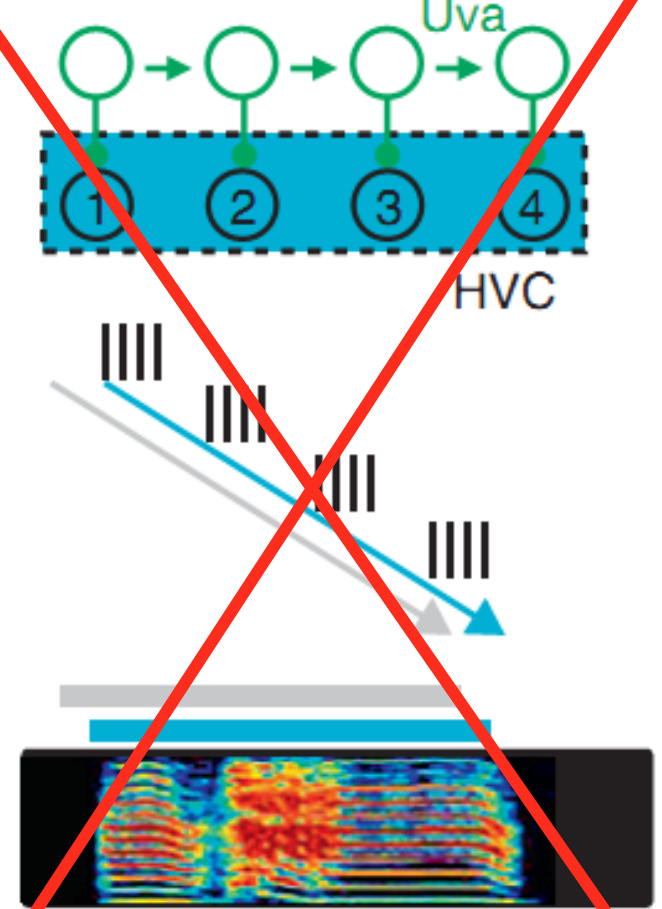

Current Opinion in Neurobiology

Where are the **long timescale** (switching between *syllables*) dynamics?

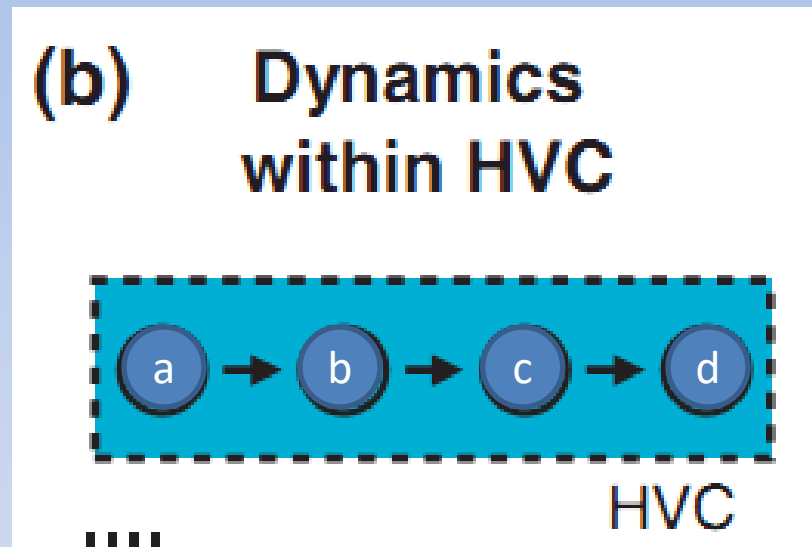

Syllable modules in HVC

Uva likely triggers short chains in HVC

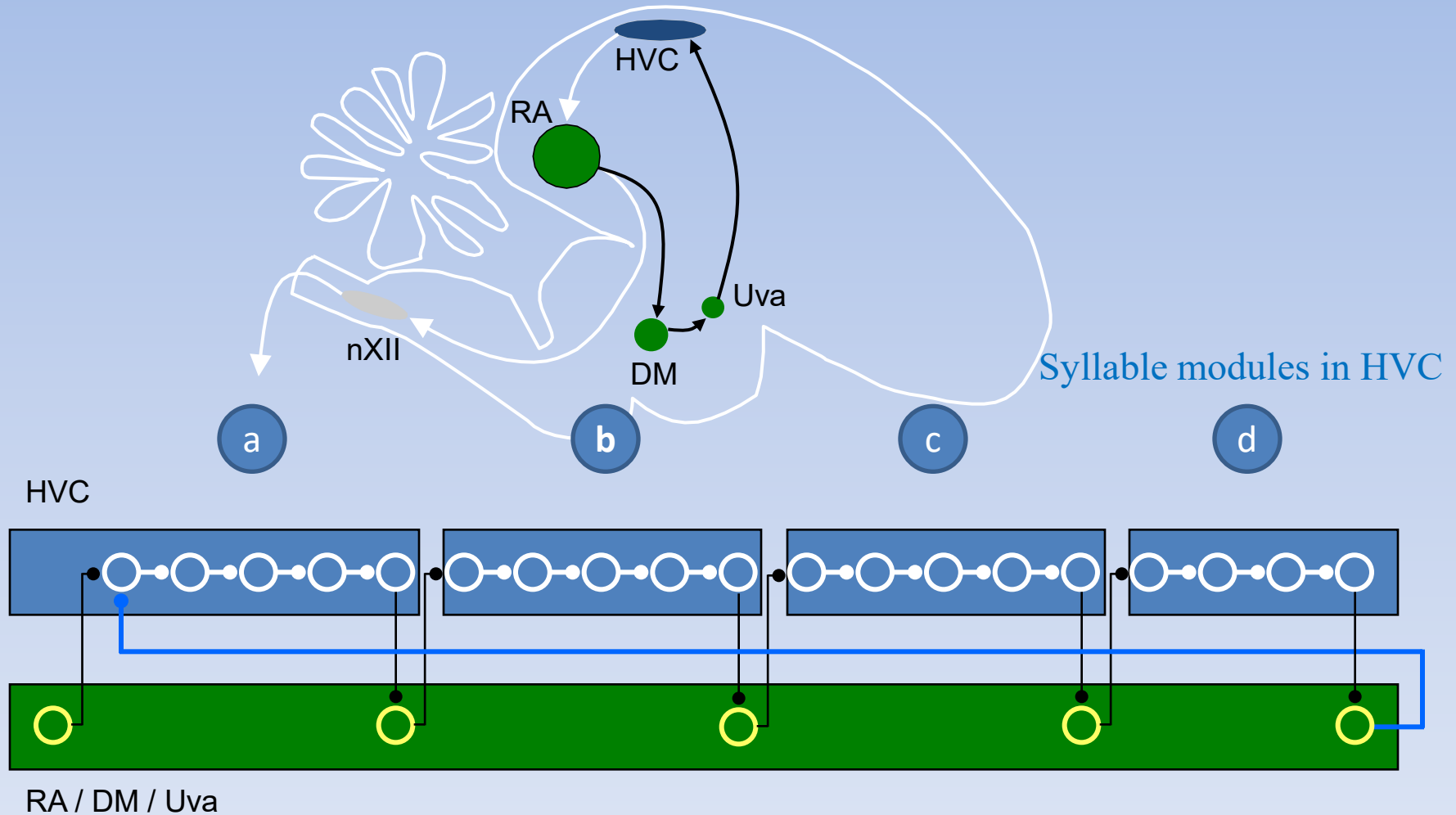

Multiunit activity in Uva shows syllable-onset-related bursts

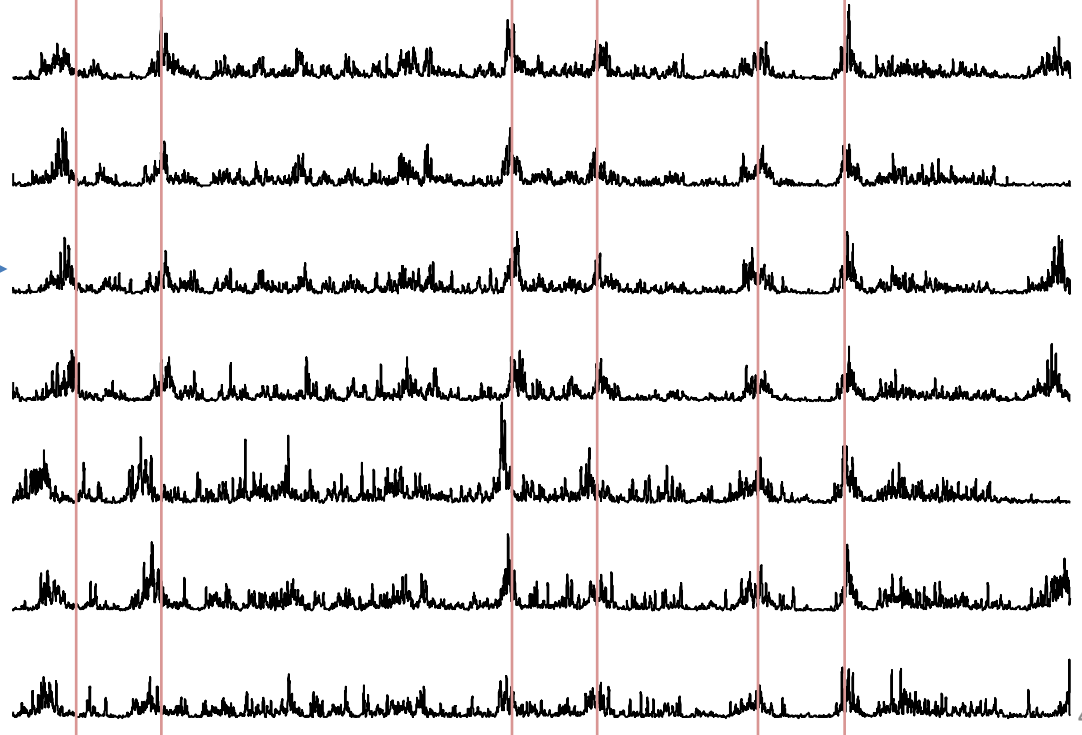
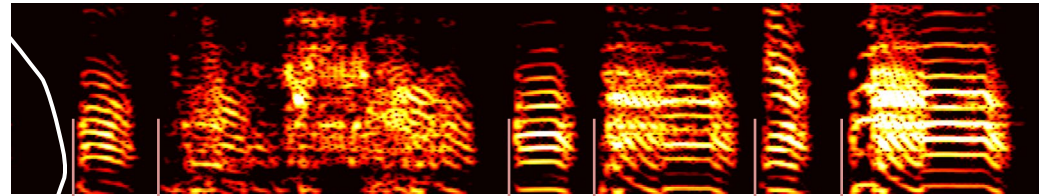
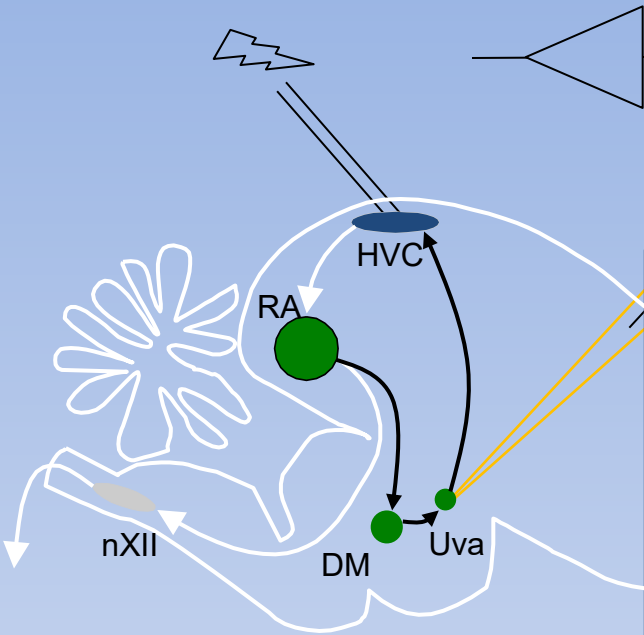

Smoothed,
rectified neural
activity

Uva - the initiator for syllable

Uva perturbation led to *truncations at the end of syllables*, indicating that *thalamic activity is critical for starting the following syllable* but not for completing the ongoing syllable (in contrast to stimulation in HVC that induce truncation in a fix time delay)

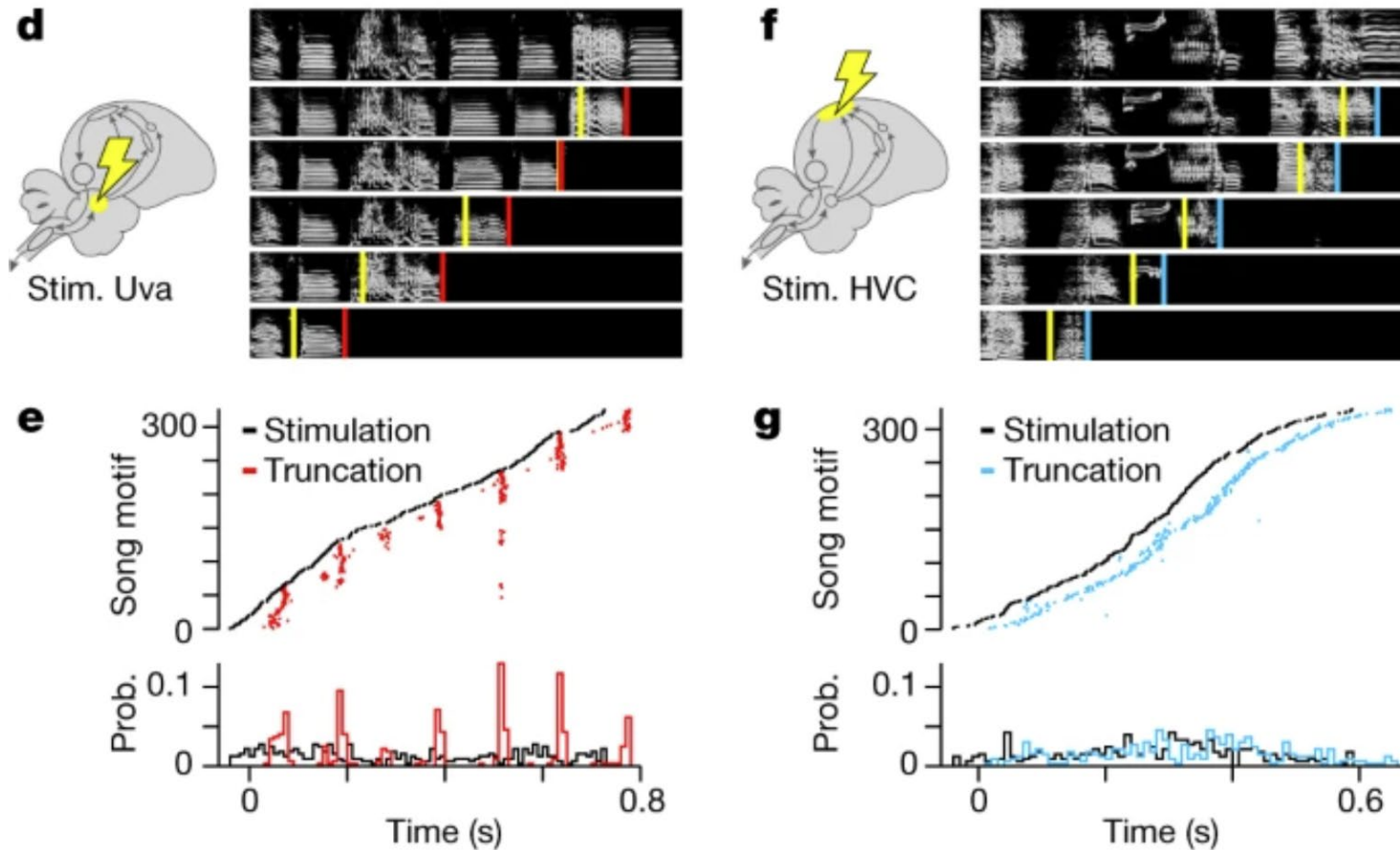

Thalamus drives vocal onsets in the zebra finch courtship song
Nature 2023 Felix W. Moll ... & Michael A. Long

Part 1: Summary – A simple model of vocal sequence generation in adult birds

HVC:

- HVC exhibits sparse bursts during singing.
- Song timing is controlled within HVC.
- HVC contains multiple syllable-modules that can be activated by midbrain/thalamic circuitry.

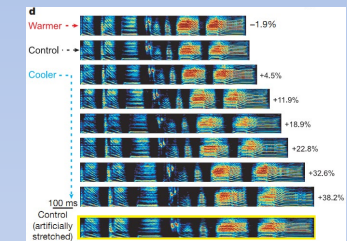
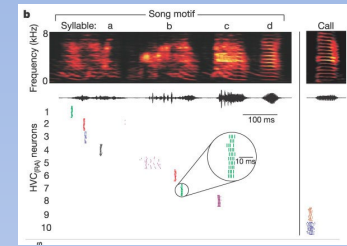

RA:

- RA transforms the sparse code into multiple bursts which then drive motoneurons.
- The configuration of the vocal organ (muscle activity) is determined by the convergent input from RA neurons on short time scale (10 - 20 ms).

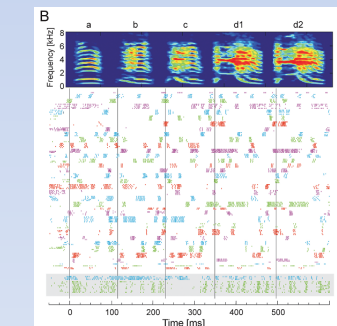

RA also gets input from LMAN!

What is the role of the learning pathway?

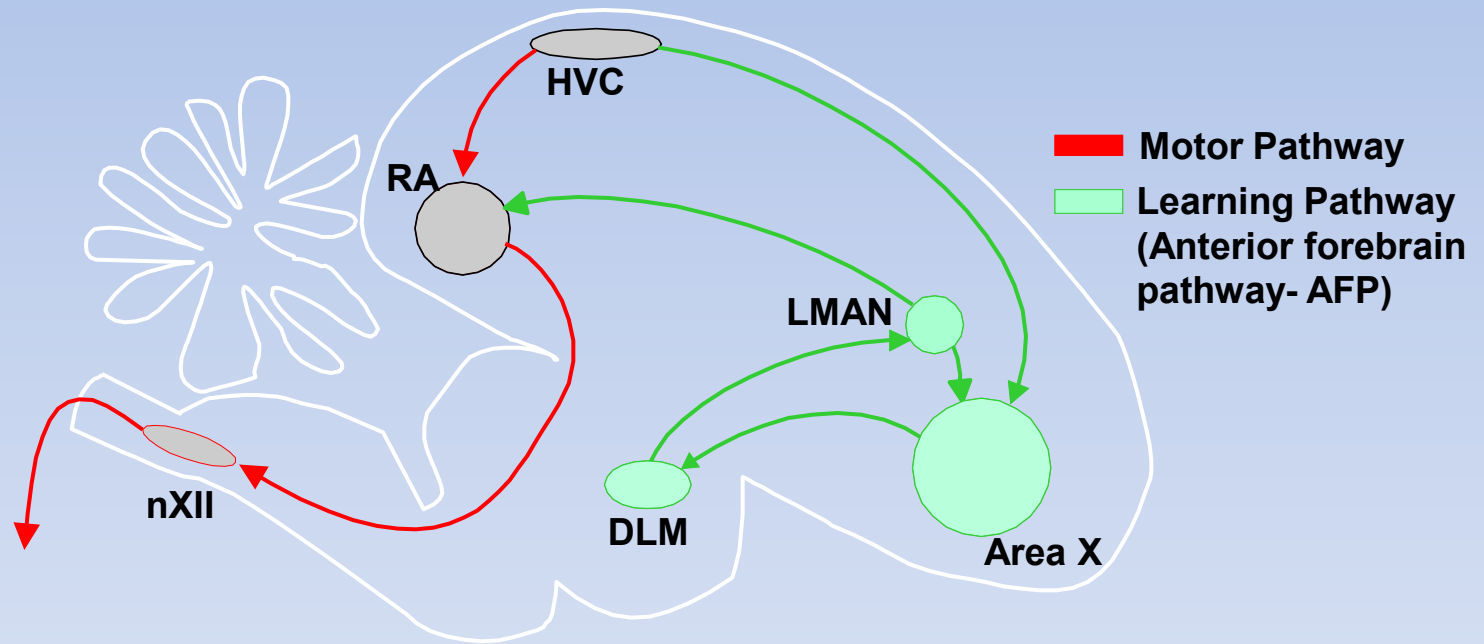

The motor pathway- if you lesion any of these song nuclei you disrupt the output of the song

The learning pathway is not necessary for adult song production, but is required for learning (Bottjer, 1984, Scharff and Nottebohm, 1991, Goldberg @ Fee, 2010)

Subsong (“babbling”) – i.e., the highly variable song in very young juveniles

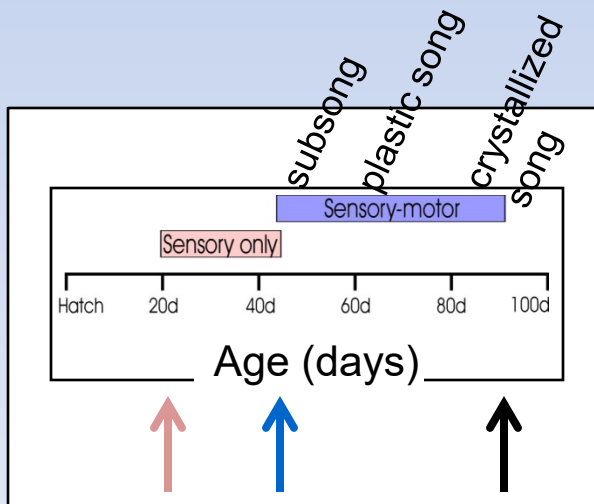
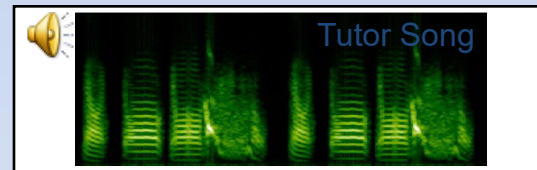
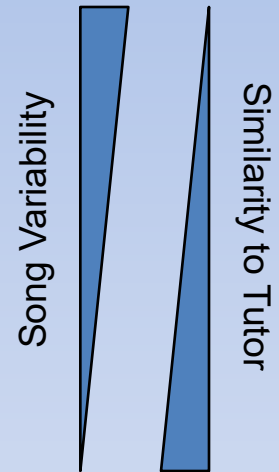
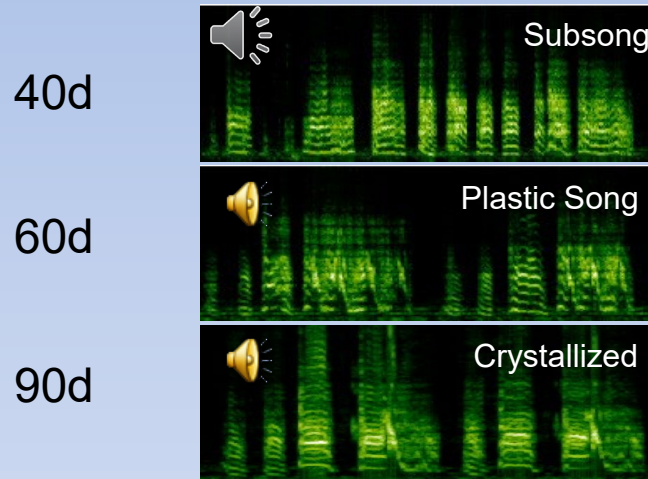

- **Question:**

What are the mechanisms that produce subsong (“babbling”) – i.e., the highly variable song in very young juveniles?

Does the motor pathway activity during subsong is similar to the activity during adulthood?

Do we need HVC for producing subsong?

“How could this be experimentally tested?”

HVC-lesioned birds could still produce subsong!

Control

no HVC

Subsong stage (37 dph)

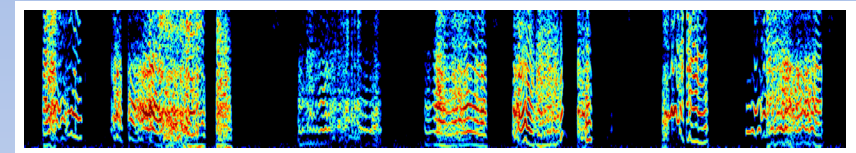
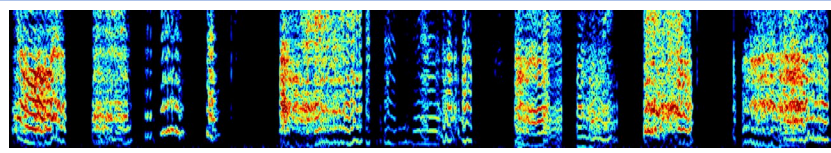

Plastic song stage (50 dph)

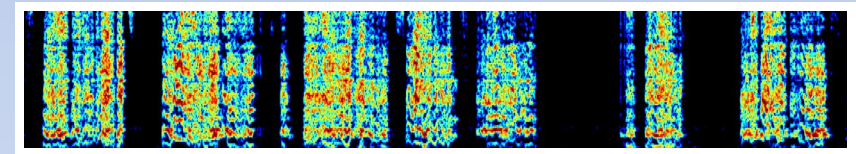
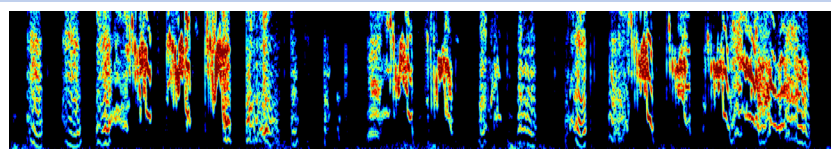

Adult

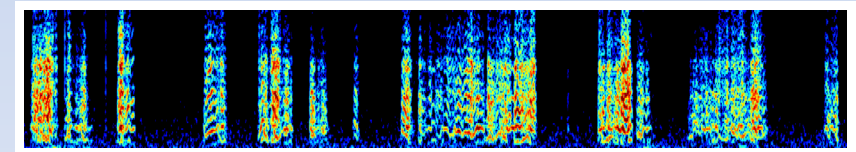
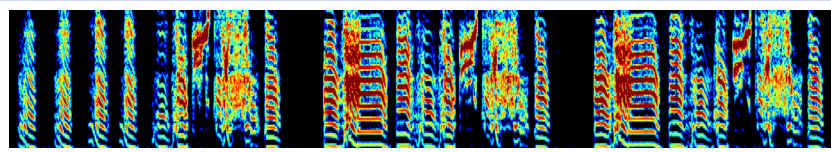

250 ms

Subsong does not require HVC

Aronov et.al. (2008) *Science*

When u lesion Uva,

the bird generate subsong! As if HVC was lesioned →
Uva is critical in the sequential activation of behavioral
modules in HVC

Bilateral complete removal of
Uva input → directed song is
abolish; undirected song turn
into subsong

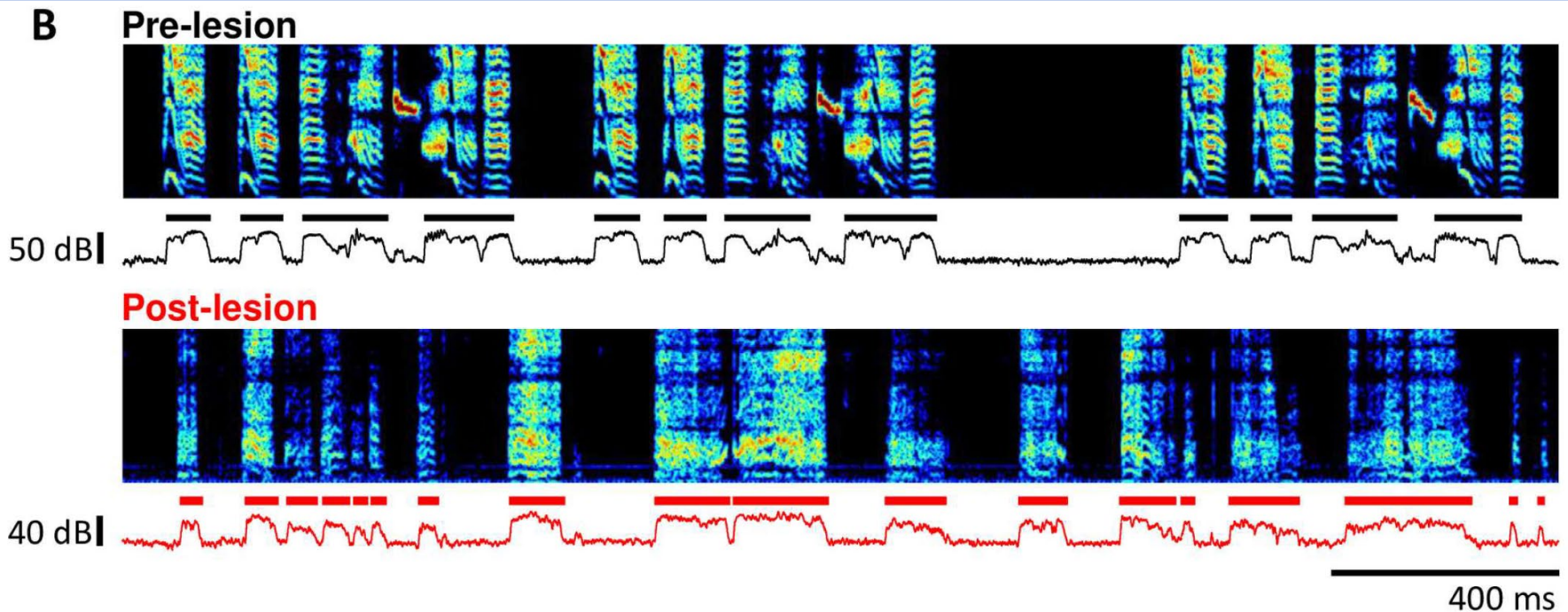
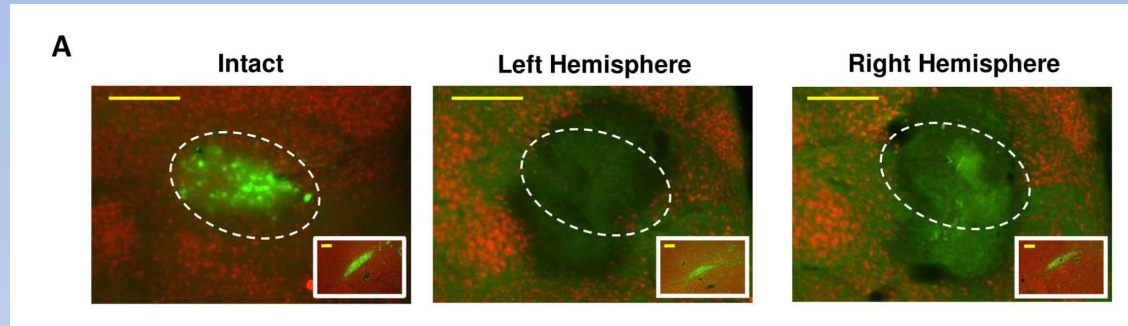

What drives *subsong* production?

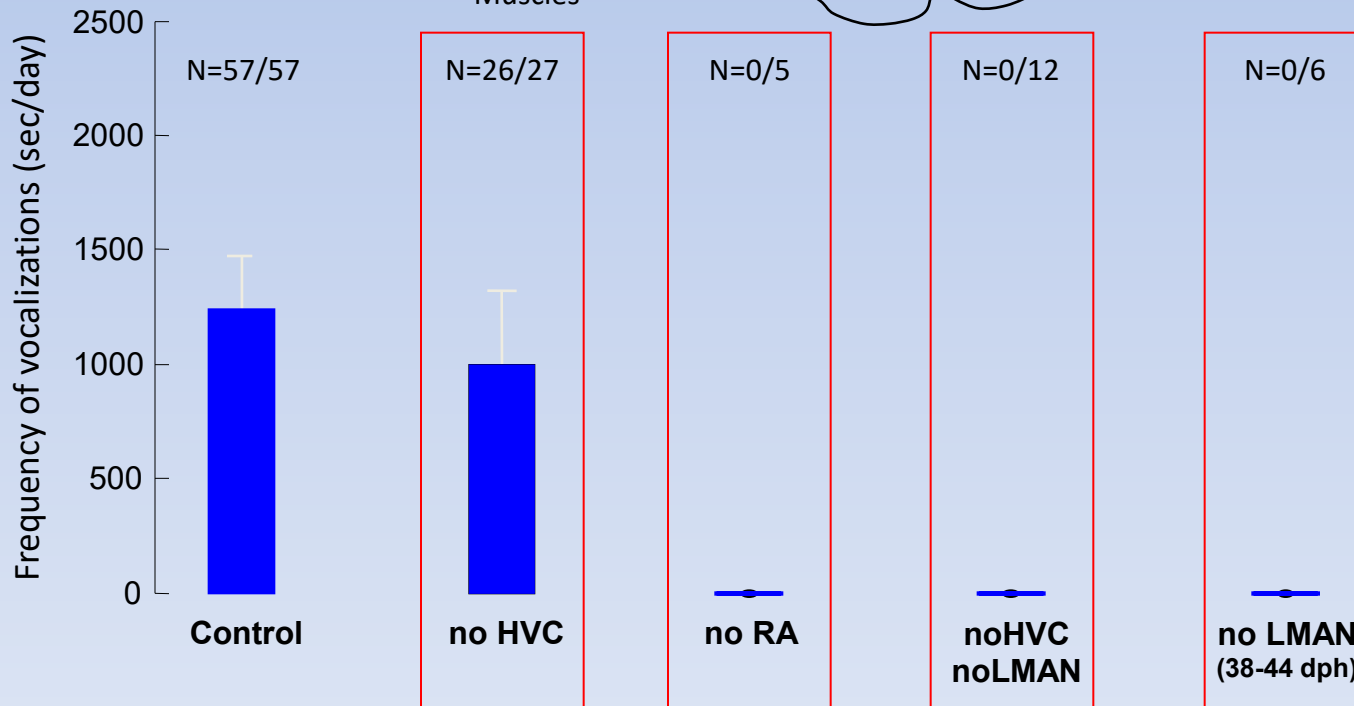
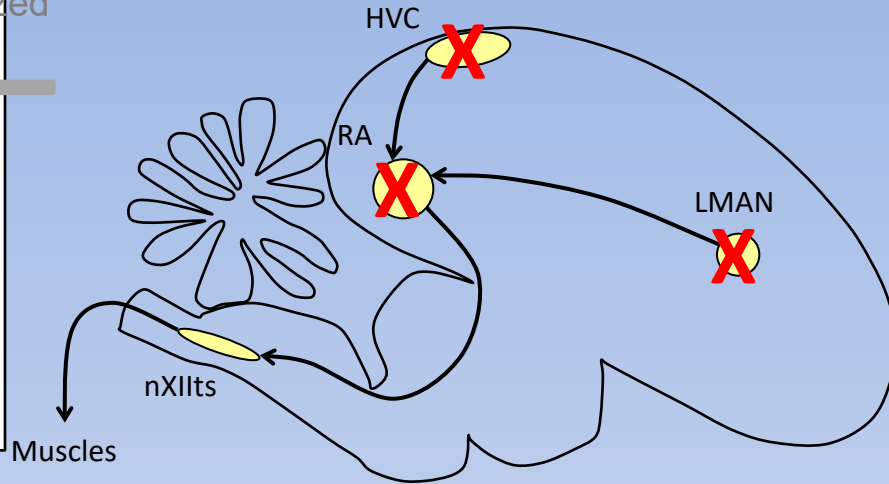
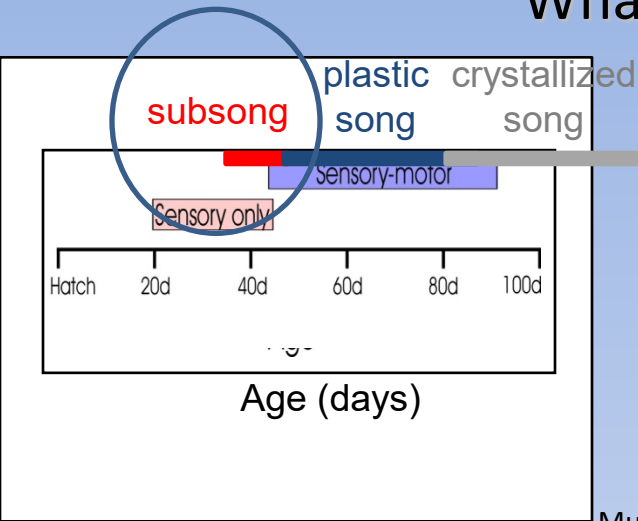

Babbling requires LMAN

LMAN drives subsong

LMAN-RA projecting neurons exhibit activity primarily prior to subsong syllable onsets

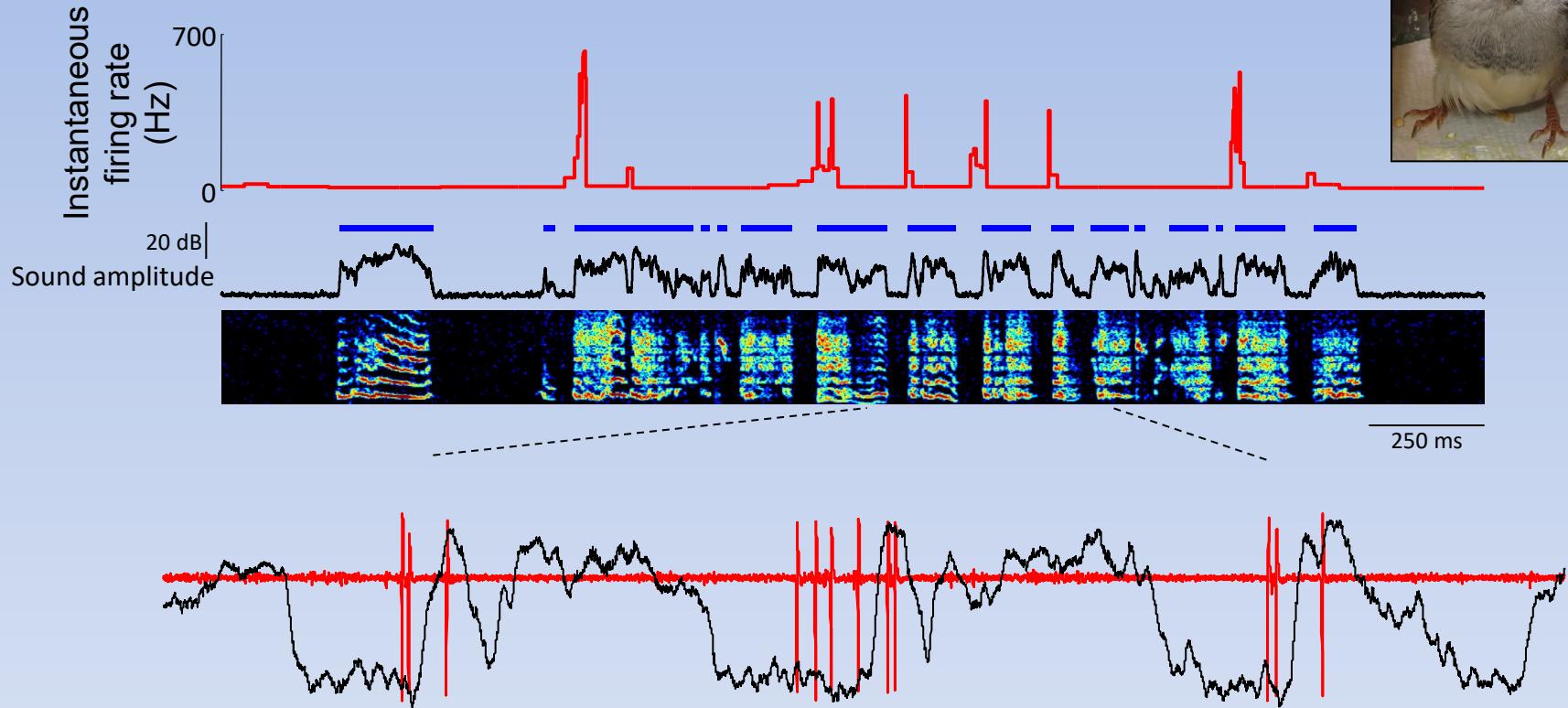

this suggest that babbling is not a result of immature motor pathway but it is actually deriving by this learning circuit

LMAN drives subsong

LMAN neurons exhibit activity also prior to subsong syllable offsets

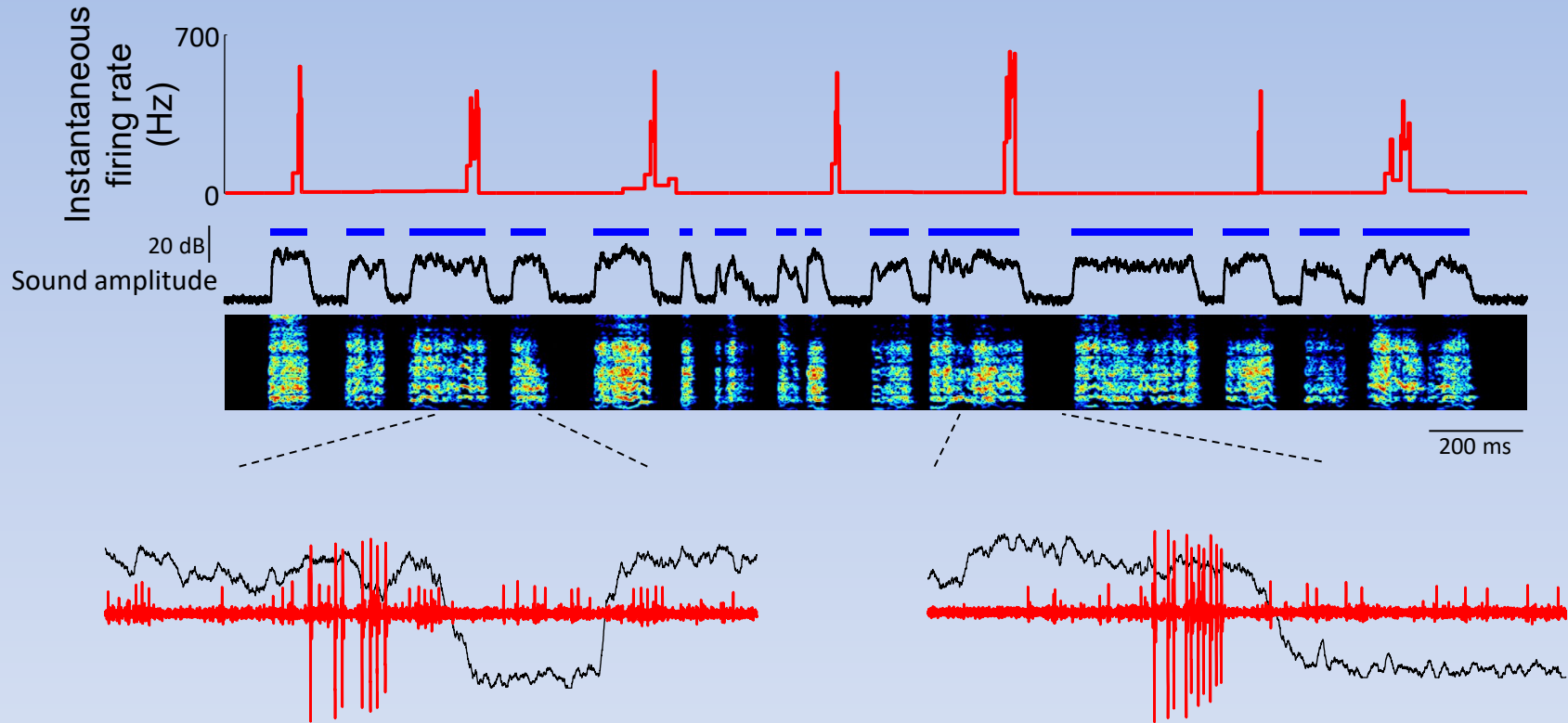

- AFP (anterior forebrain pathway) is necessary for producing subsong, suggesting that this circuit is important for vocal variability.
- Which part of AFP is necessary for producing babbling?

The basal ganglia (area X) are not necessary for subsong or vocal variability. DLM is necessary for the production of subsong (without \uparrow song stereotypicity). LMAN \rightarrow RA pathway cannot generate subsong like vocalizations independent of DLM.

motor thalamus plays a key role in the expression of exploratory juvenile behaviors during learning

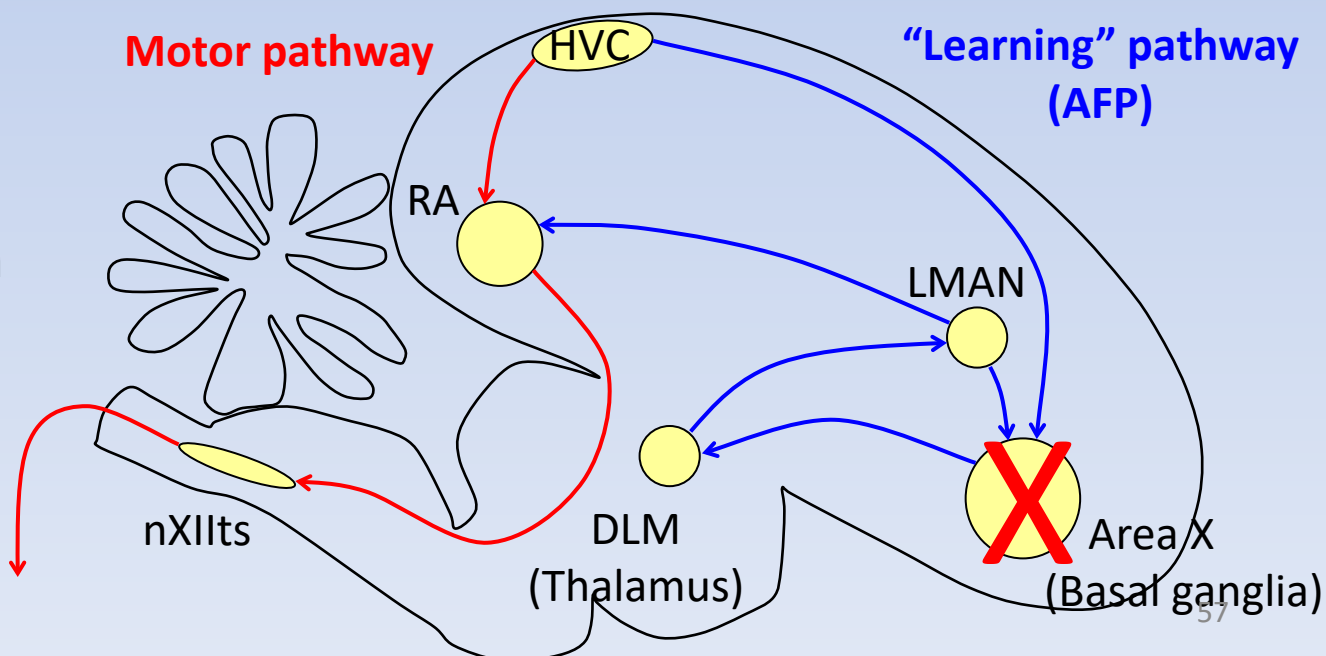

- **Question:**

What is the role of LMAN in older juveniles?

What drives *plastic* song production?

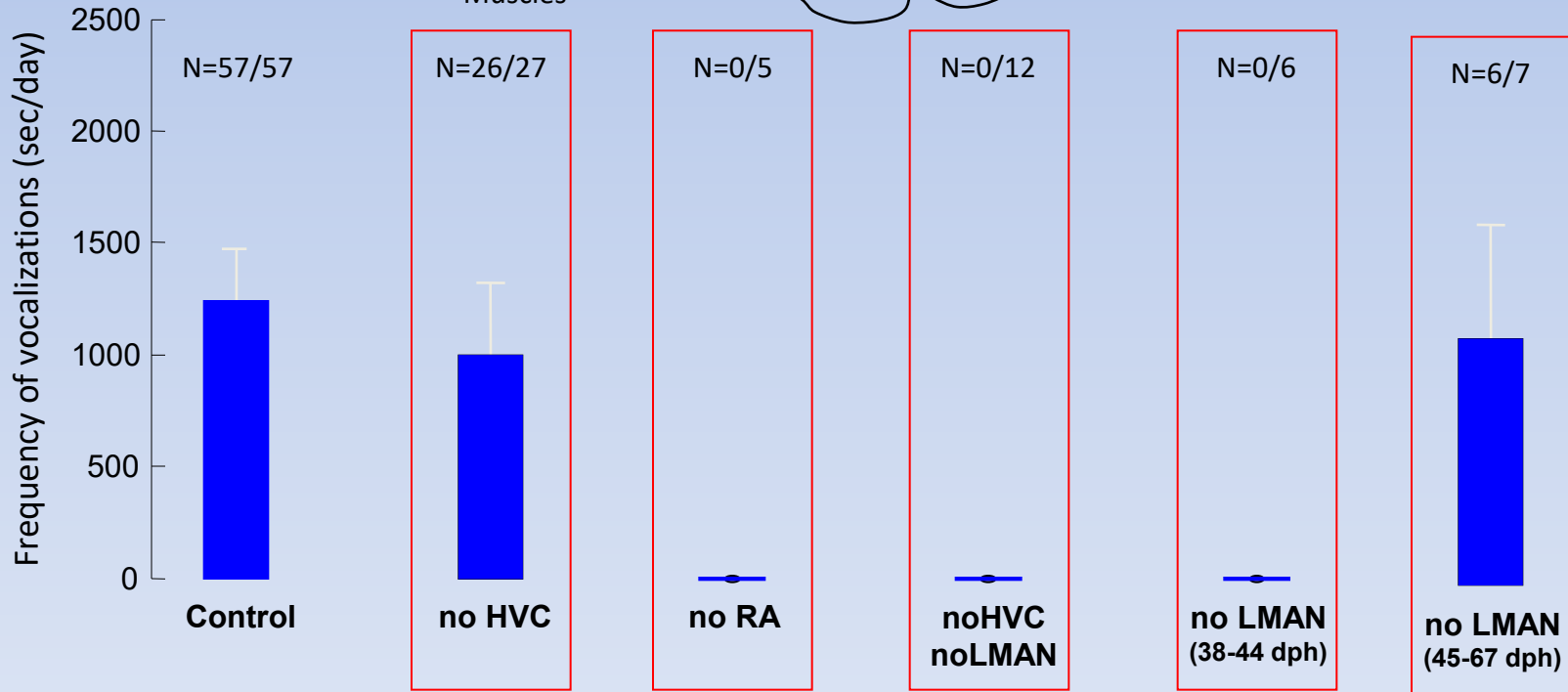
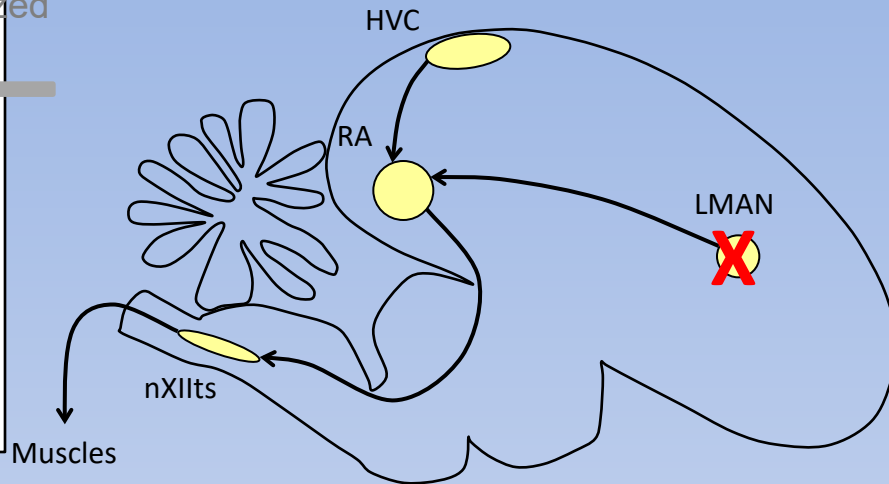
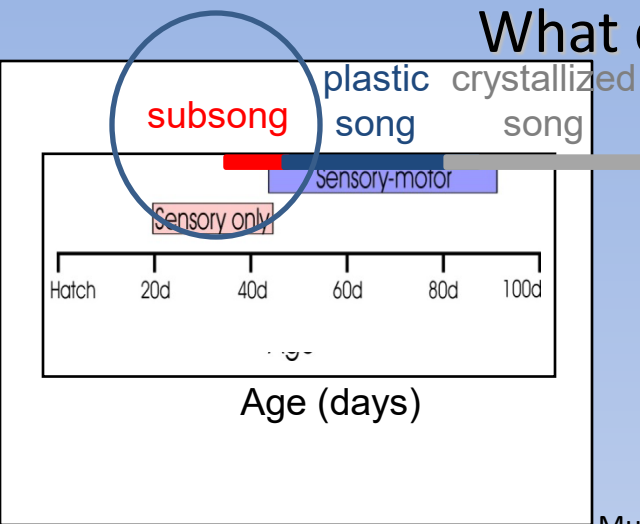

Aronov et.al. (2008) *Science*

At age 45-67 lesion LMAN → bird sing, but what about song features?

What drives *plastic song* production?

Remotely delivering drugs into the brain without physically handling the bird

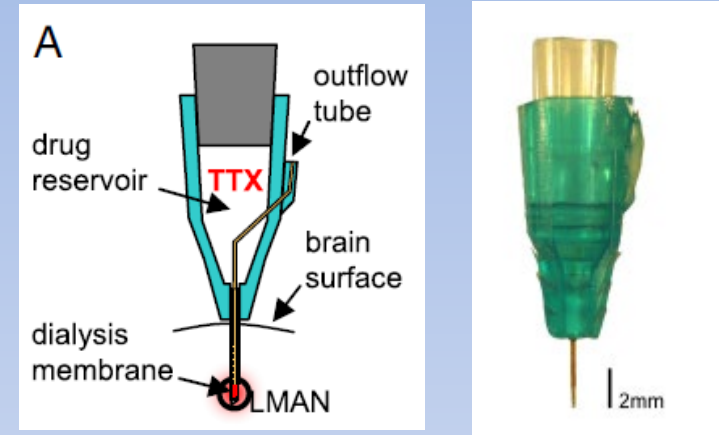
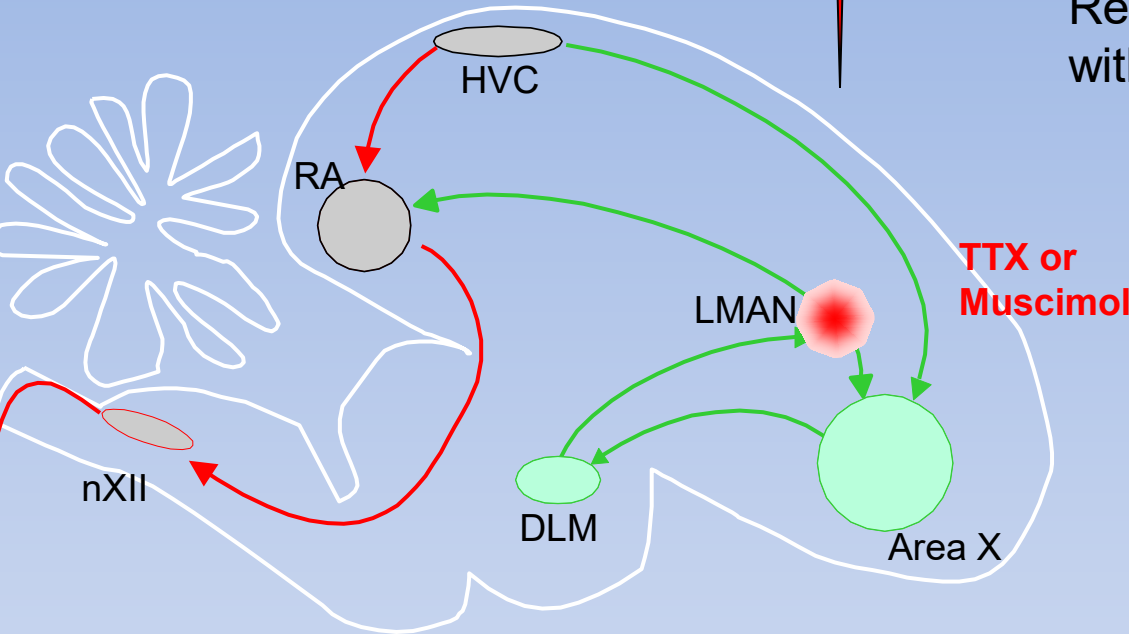

LMAN intact

Subsong/plastic song requires LMAN

Babbling requires LMAN → LMAN give rise to a high variability sounds, whereas HVC is slowly taking over to give structure into the song

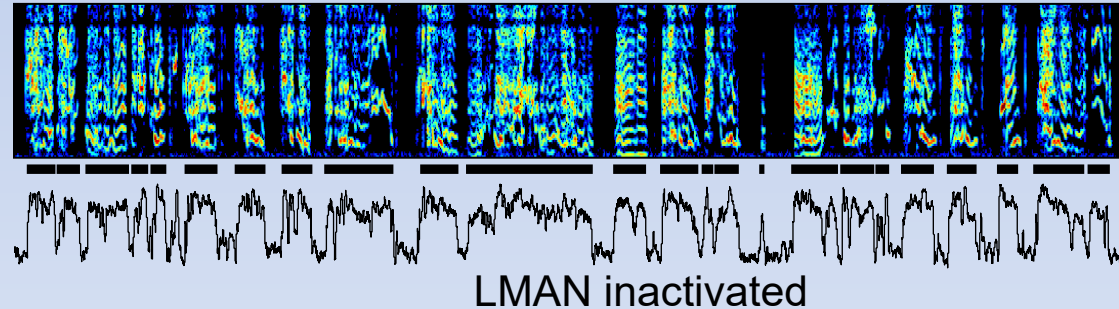

LMAN inactivated

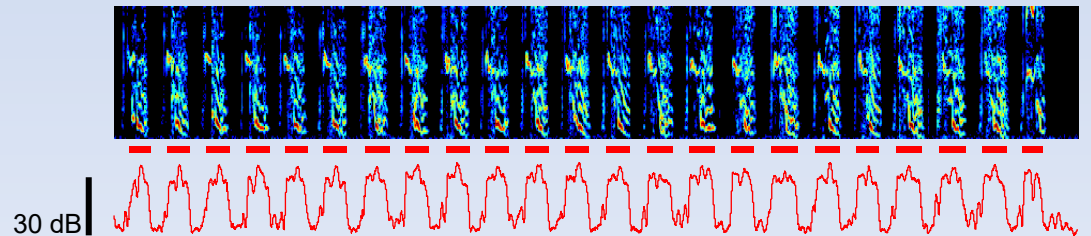

250 ms

Role of LMAN in a bit older juveniles

LMAN is a generator of variability

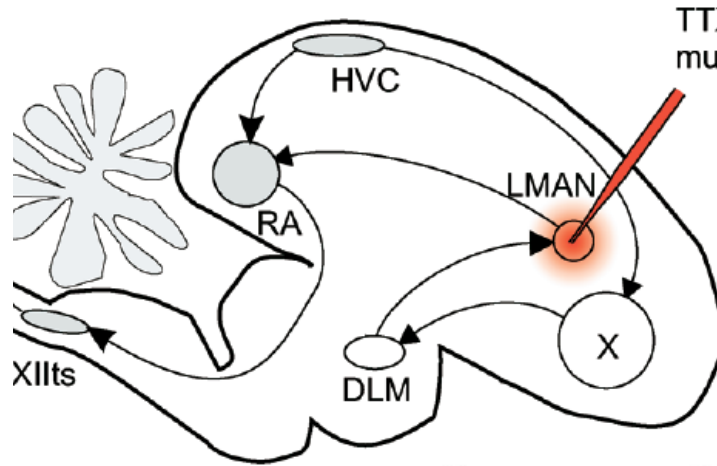
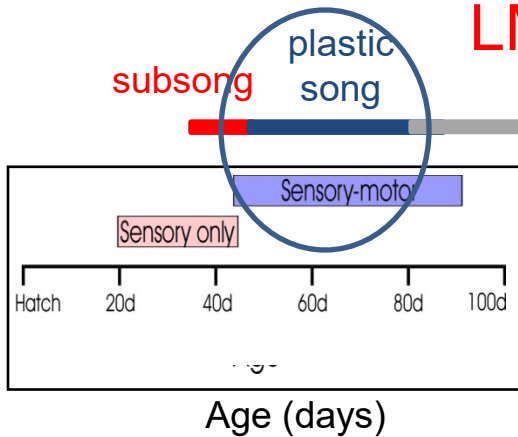

The capability of singing a structural song is there very early. AFP injecting variability into the song → active exploration

Before LMAN inactivation

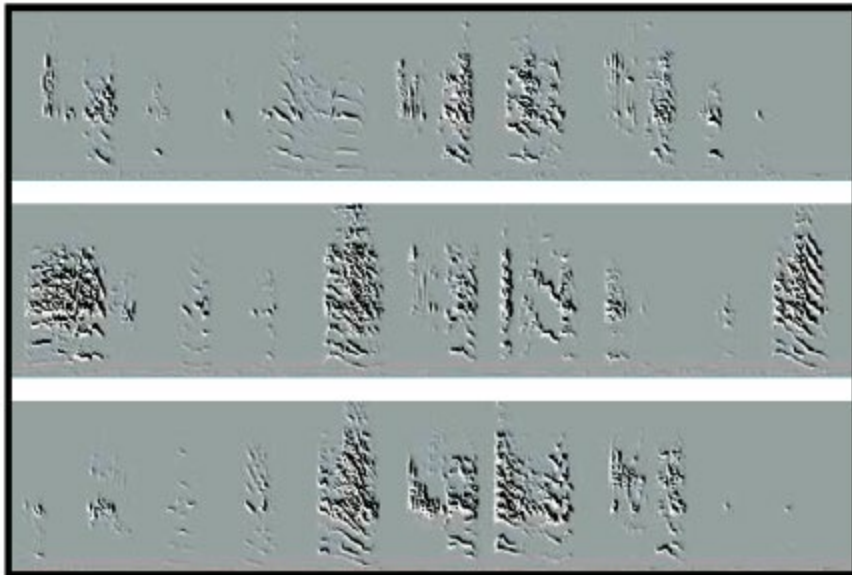

C

During LMAN inactivation

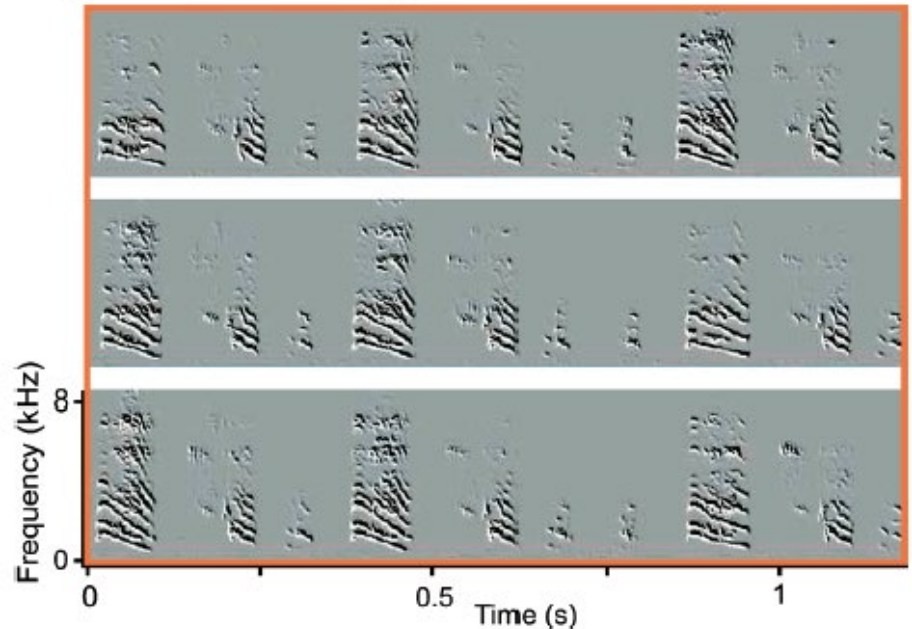

Separate premotor pathways for stereotyped song and babbling

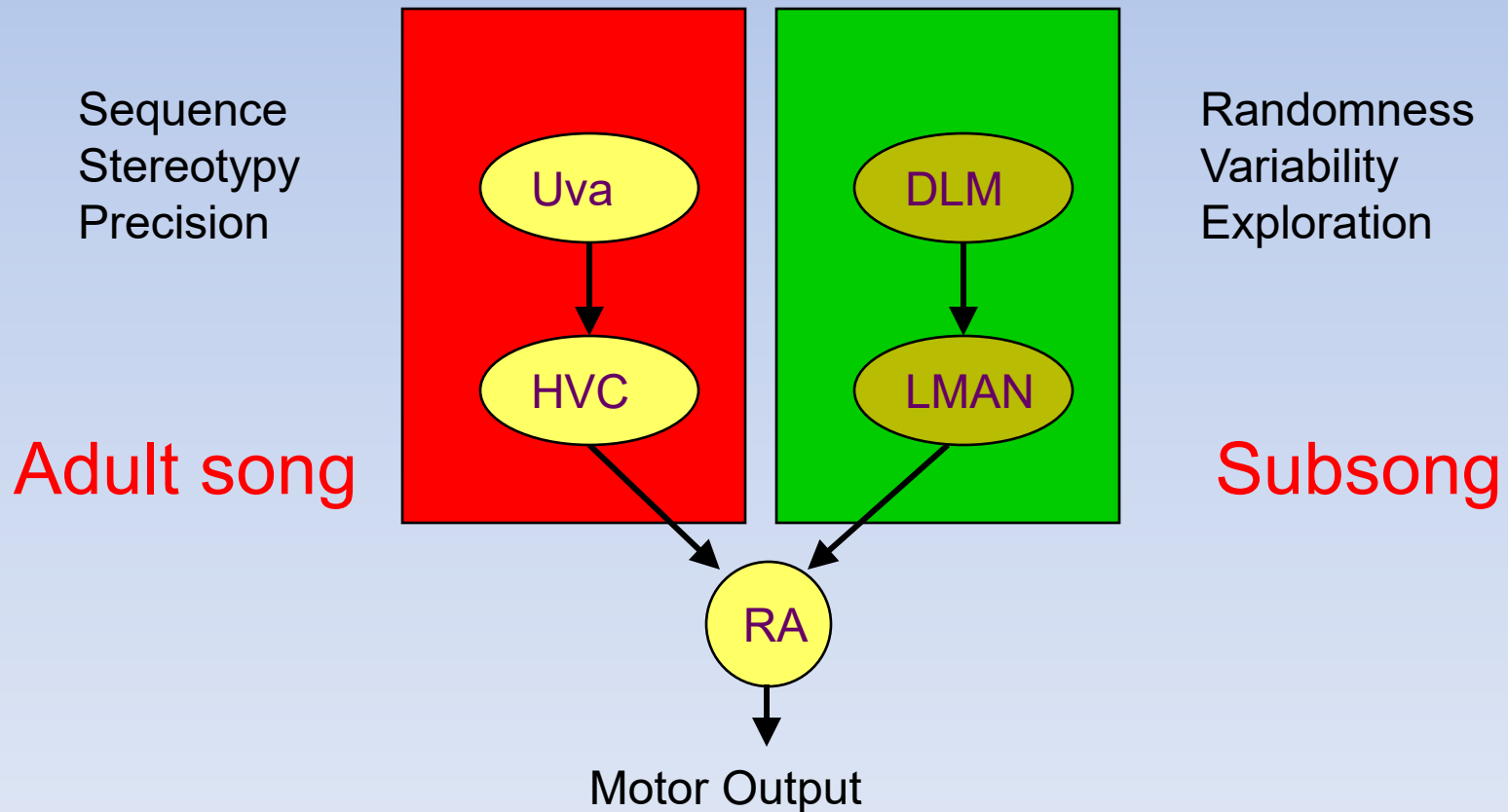

Reduced variability in pitch after LMAN inactivation during crystalized song

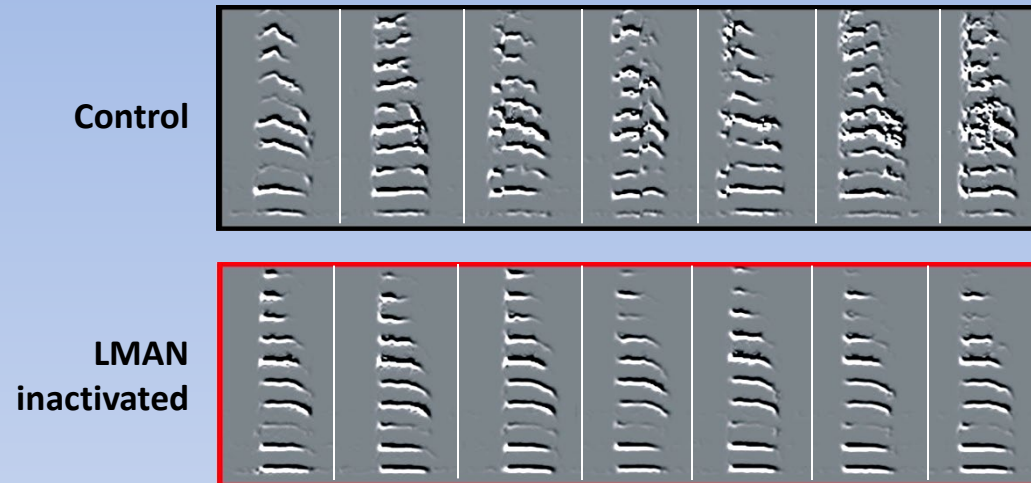

LMAN involves in injecting stochastic noise into the naive behavior so to have more variation on which to select the better performance.

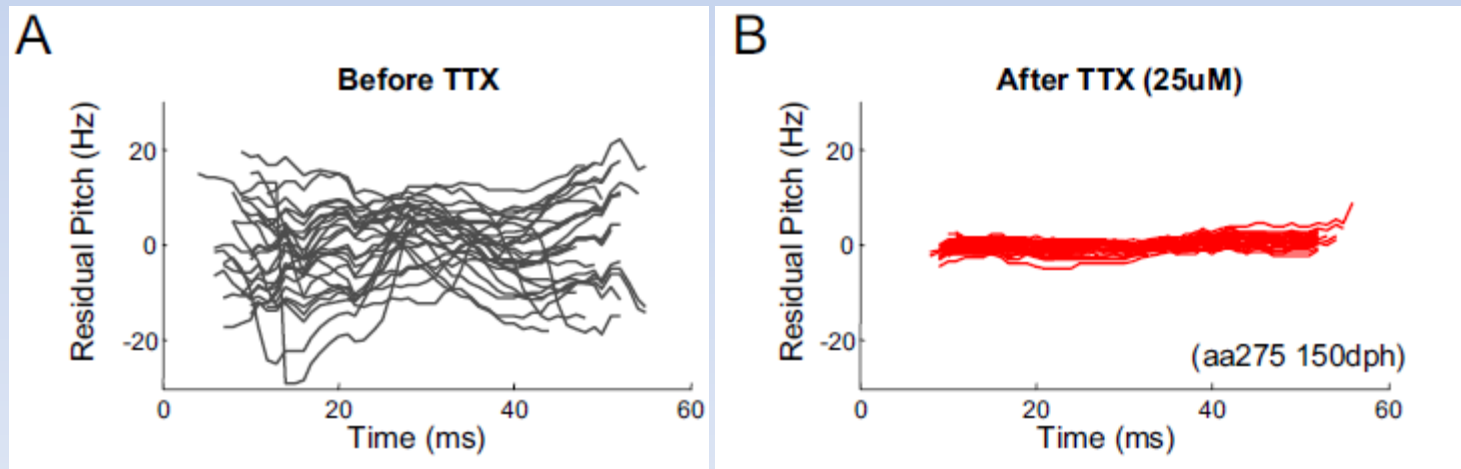

LMAN activity in older juveniles

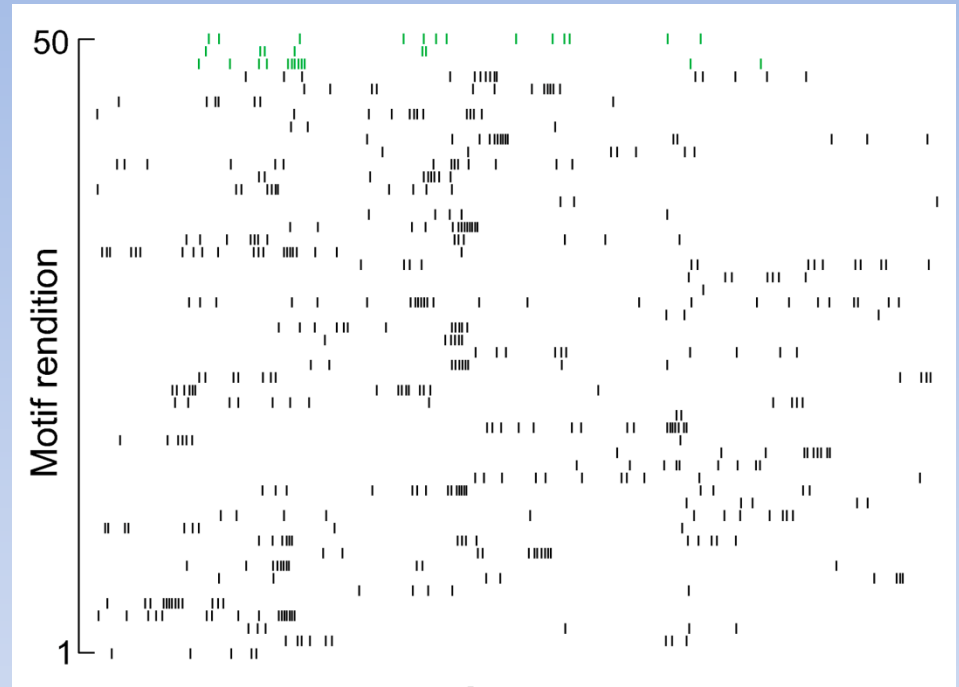
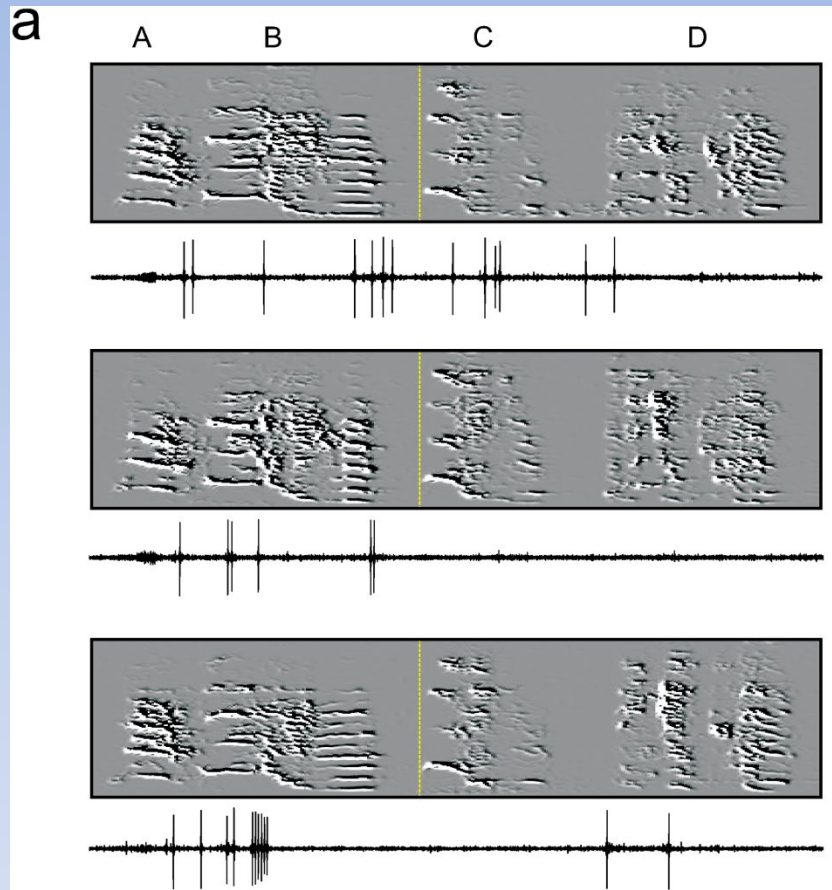

Almost no structure in LMAN firing

The crystallized songs of male zebra finches display different amounts of acoustic variability depending on social context

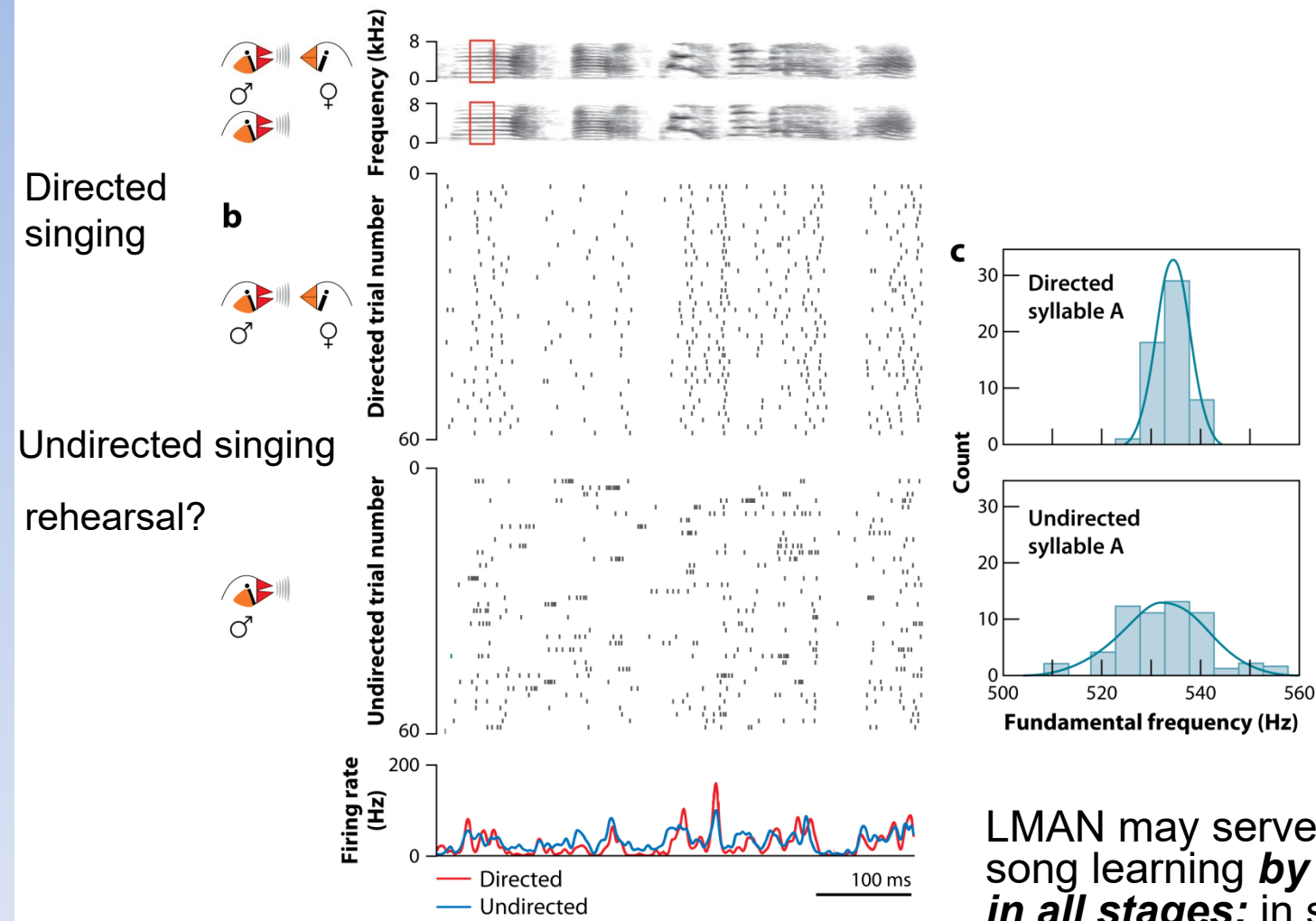

LMAN may serve an essential role in song learning **by driving variability in all stages:** in subsong, plastic song, and even in adult song.

Role of LMAN in learning

- Question

Is variability purely random or is it biased?

- Difficulty

Song learning is a slow process.

- Strategy

Use real-time feedback to induce error in the song artificially (**using young adult- (1) sing a lot, (2) still show high variability**)

Conditional auditory feedback

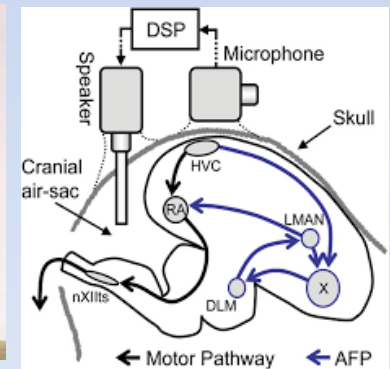
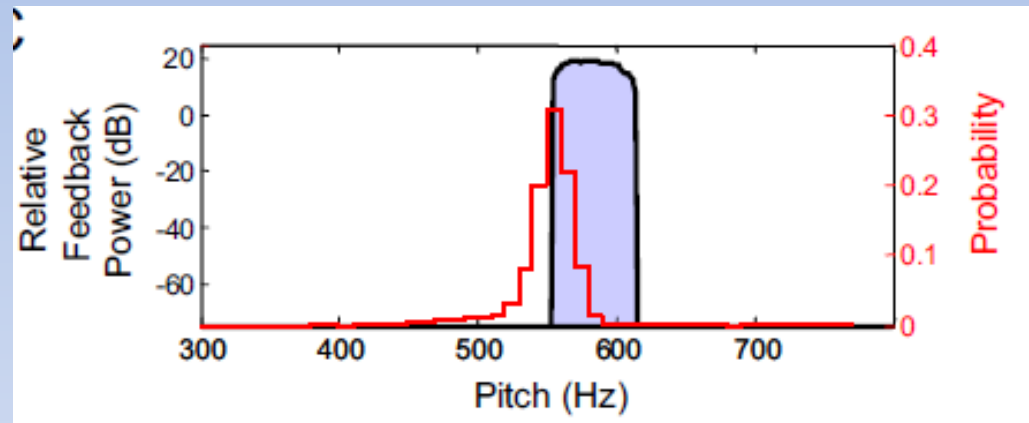
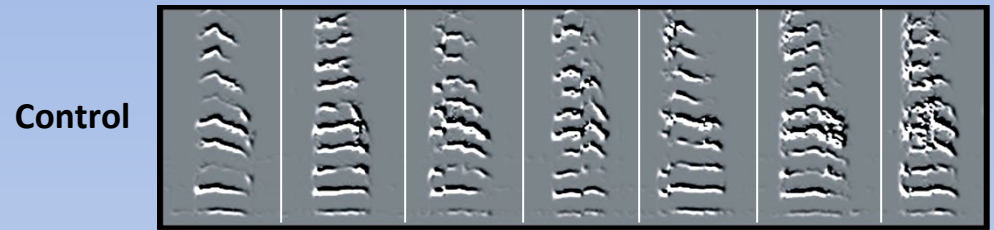
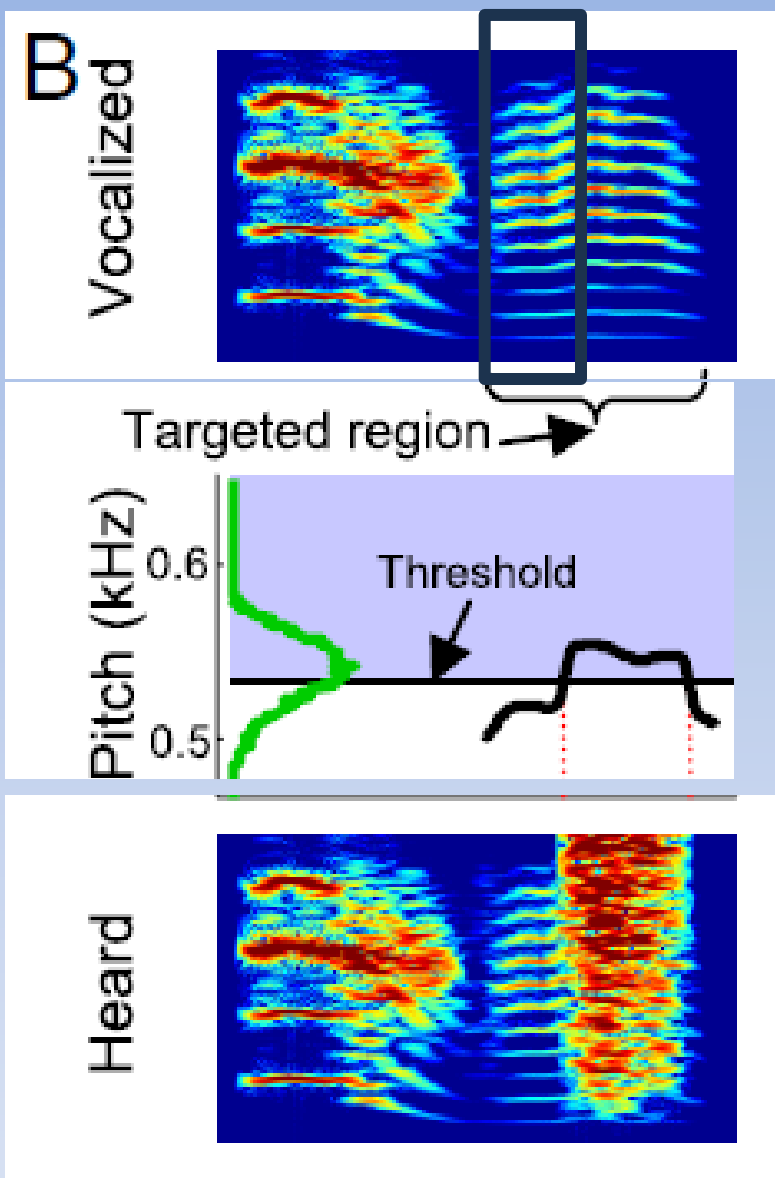

Tumer & Brainard (Nature, 2007)
 Andelman & Fee (PNAS, 2009)

The AFP does more than generate variability!

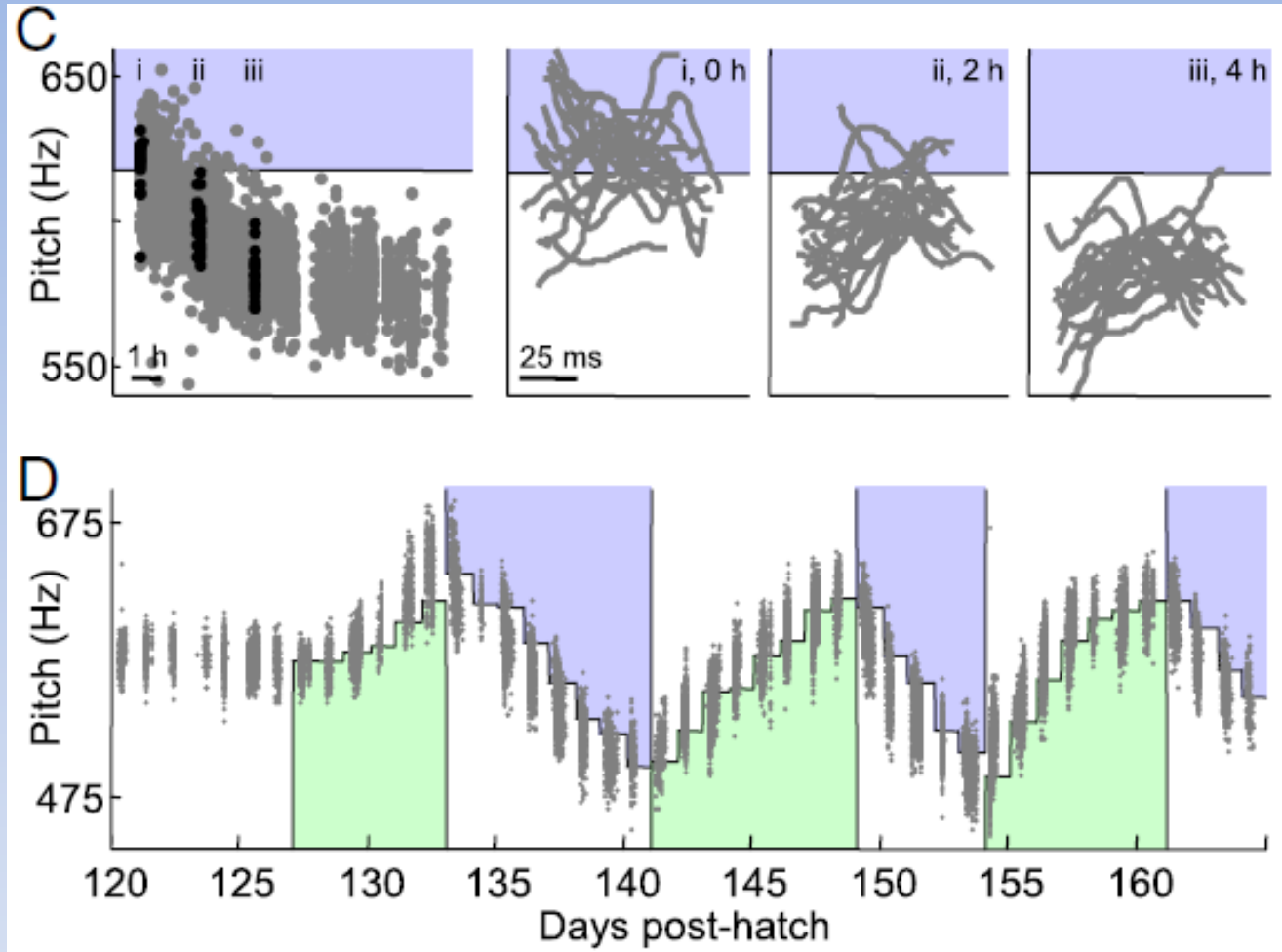

This means that the noise injected by the AFP into RA has to be biased → it doesn't change the signal around an average but pushes the pitch away from the noise in a more directional way.

Two possibilities

Where does the learning take place?

- **Hypothesis 1: motor pathway**

→ LMAN inactivation will not change the pitch.

- **Hypothesis 2: learning pathway**

→ LMAN inactivation will change the pitch to go back.

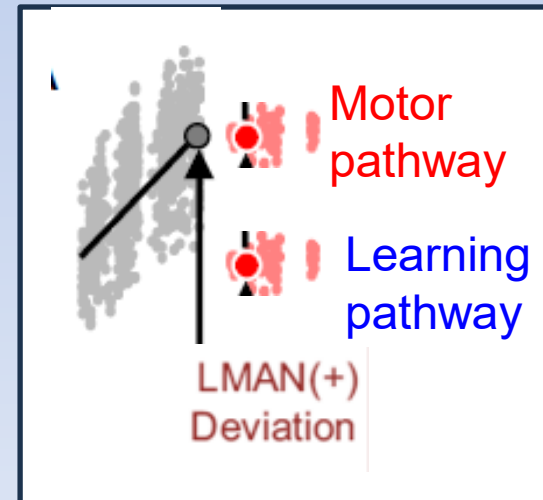
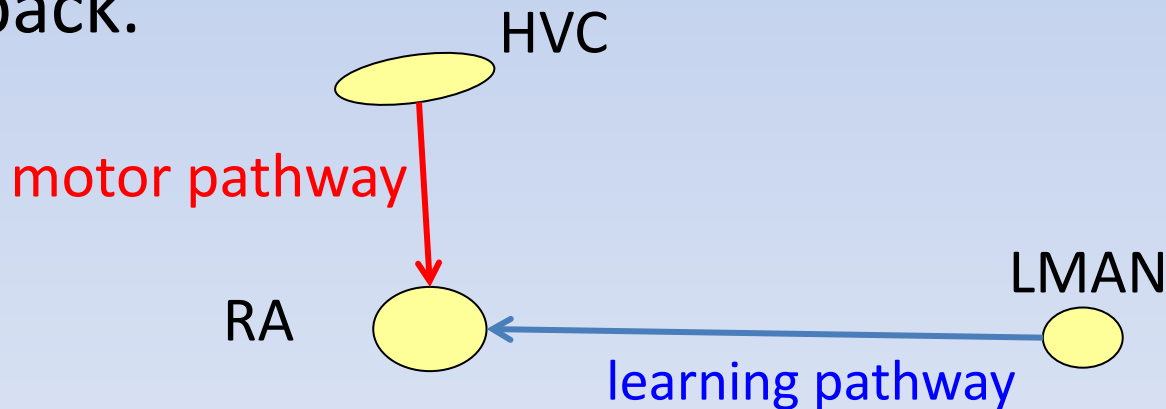

Motor pathway consolidation

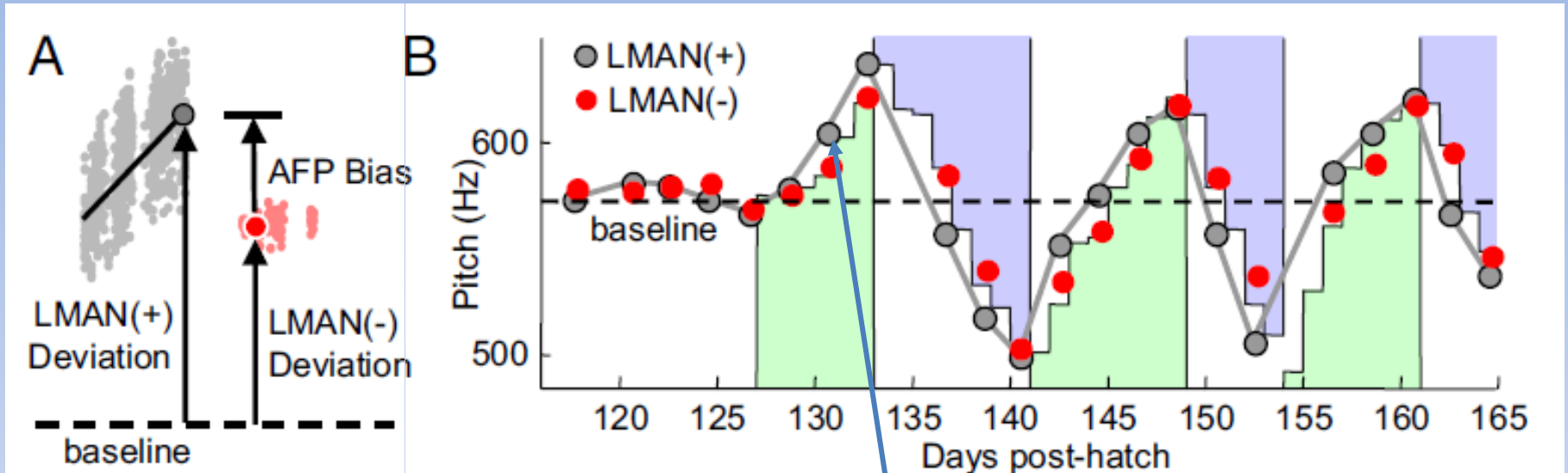

Inactivation of LMAN at the end of the same day showed that ***no consolidation has occurred***

But overnight there is already a change of pitch!

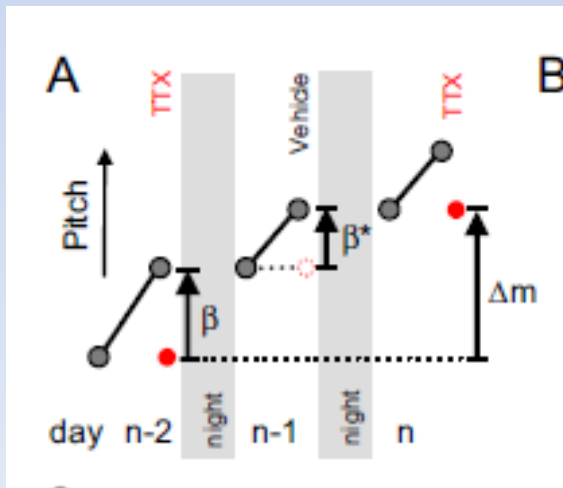

The variability produced by the learning pathway is not purely random, but instead biased. The bias is consolidated in the motor pathway after one day delay.

Learning pathway

Andalman & Fee (PNAS, 2009)

LMAN is a generator of variability

- LMAN is the **essential** premotor nucleus for the earliest **babbling** vocalizations (Aronov and Fee, 2008).
- LMAN may serve an essential role in song learning **by driving variability in all stages**: in subsong, plastic song, and even in adult song (Kao et al, 2005).
- **LMAN adds variability to enable exploration**. This variability produced by the learning pathway is **not purely random**, but instead **biased**.
- This bias is **consolidated** in the motor pathway after one day delay.

Separate premotor pathways for stereotyped song and babbling

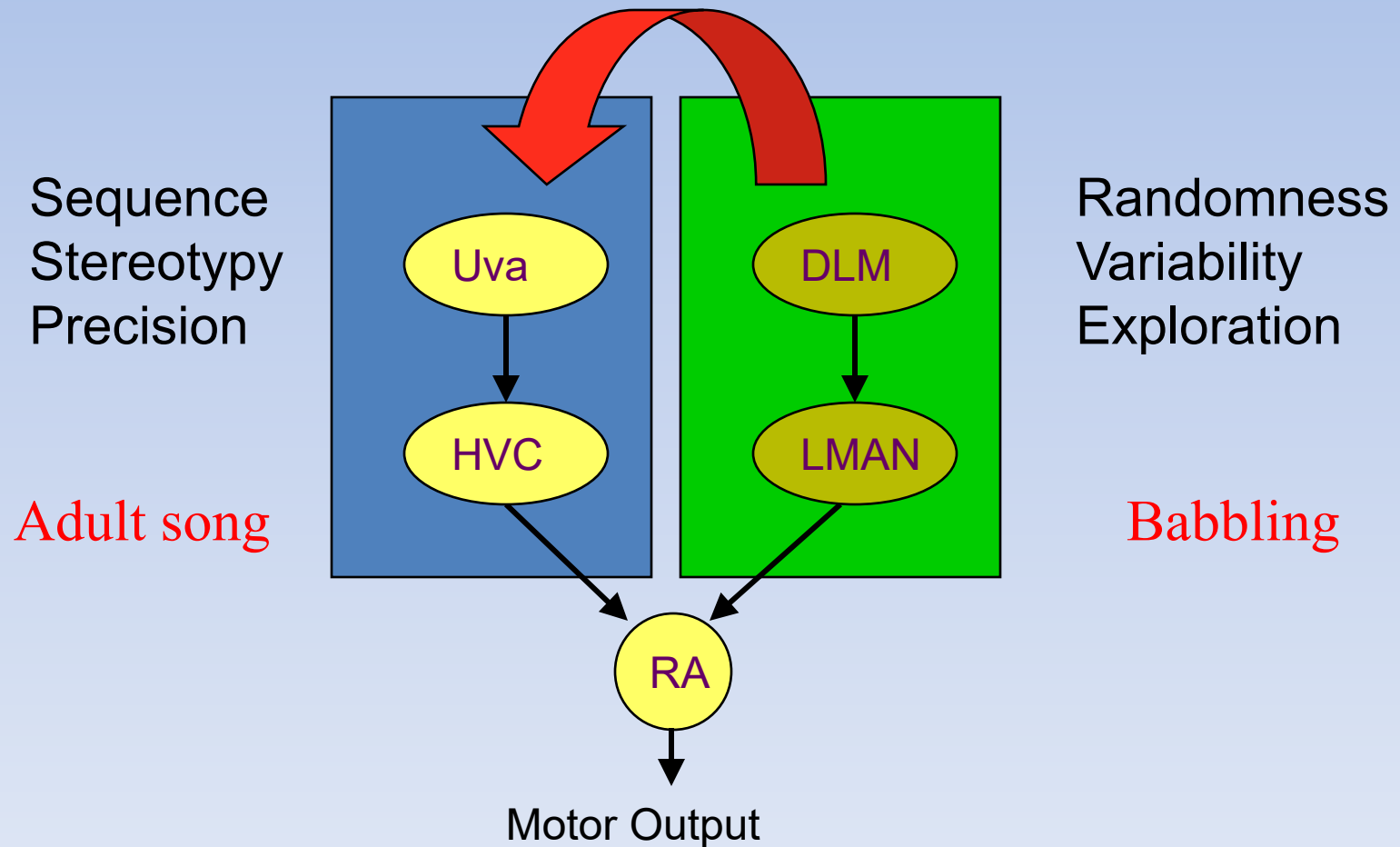

Going back to adult: what is behind the stereotype directed singing vs the more variable undirected song

The crystallized songs of male zebra finches display different amounts of acoustic variability depending on social context

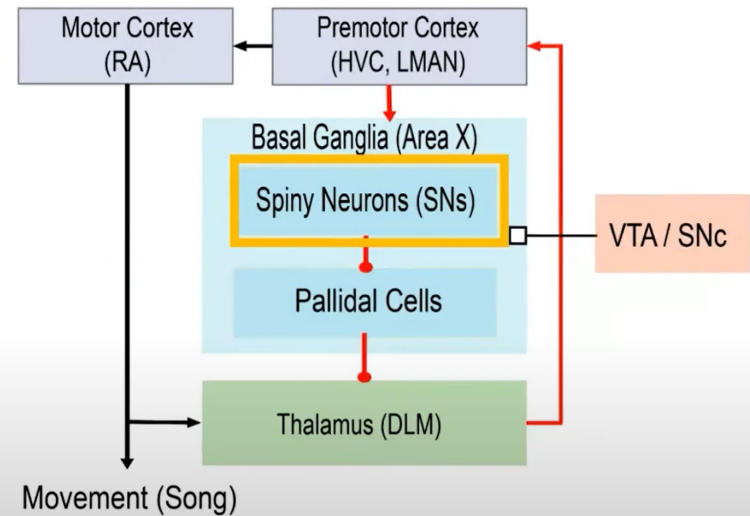
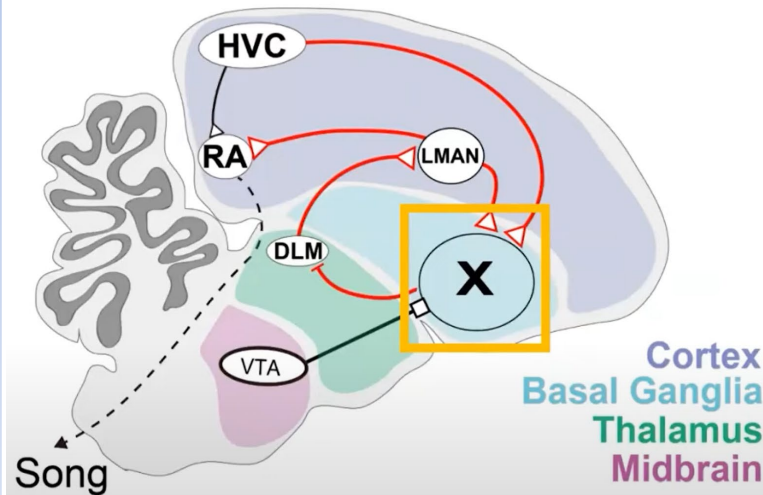
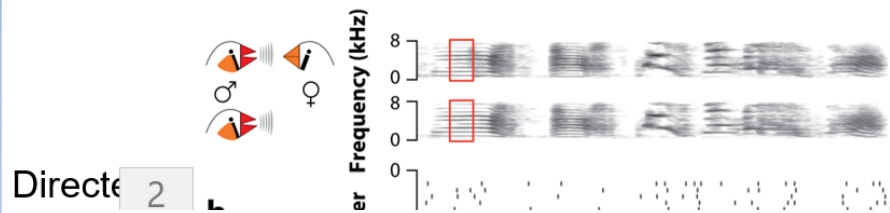

— Directed
— Undirected
100 ms

song learning **by driving variability in all stages:** in subsong, plastic song, and even in adult song.

Imaging neural activity in singing birds

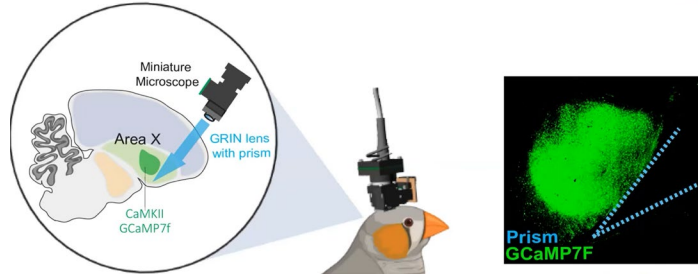

Ensemble activity of Spiny neurons in area X
During practice mode: is song-specific and highly variable
During directed song: activity is suppressed

Injecting Noradrenergic reduces vocal variability by directly suppressing SN activity (probably revealing suppression mechanism during directed song **locus coeruleus (LC)**)

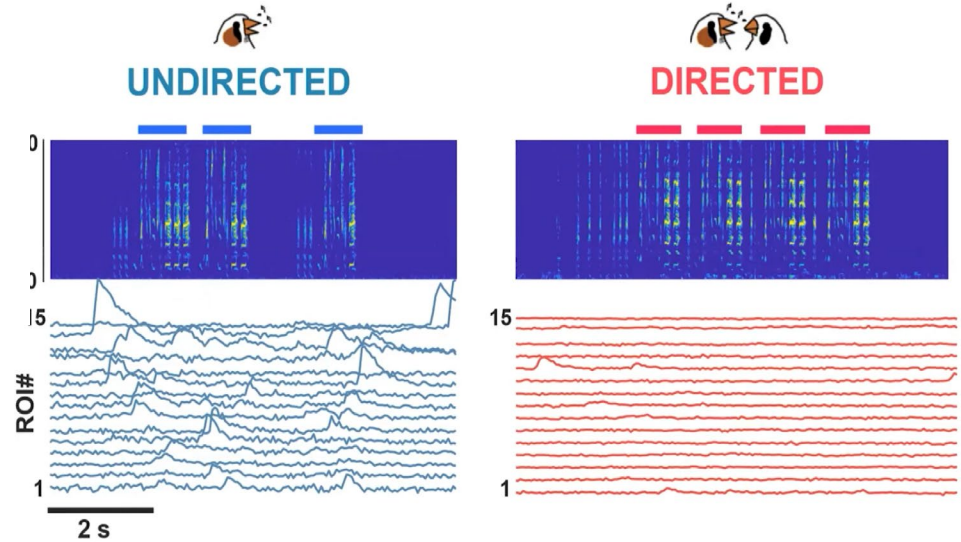
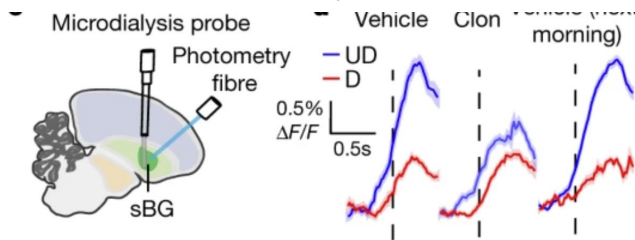

Optically silencing spiny neurons reduces variability seen in undirected song

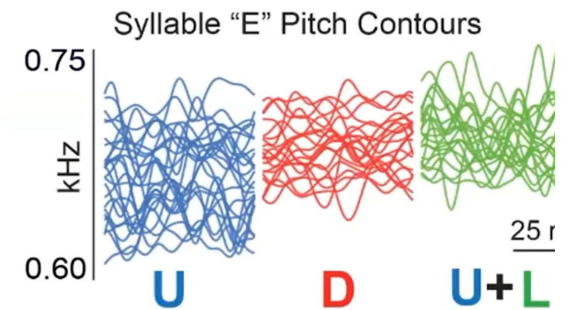
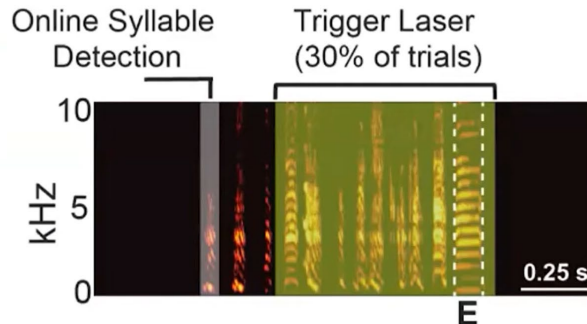
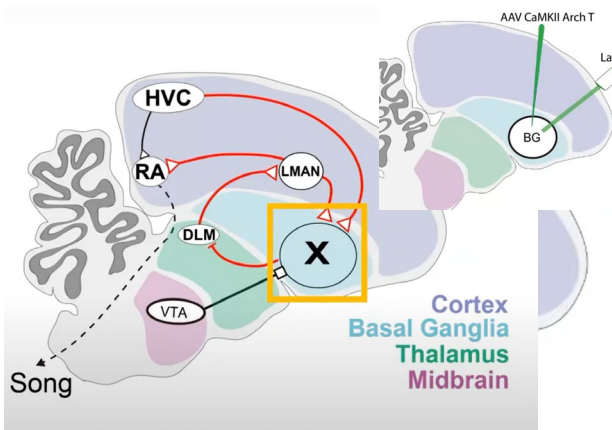

Innate versus learned

- Is there any component in the vocal learning that is innate?

https://www.youtube.com/watch?v=fOIM1_xOSro



ali g interviews noam chomsky

Chomsky



Chomsky's linguistic theory

Noam Chomsky proposed in the 60s that the principles underlying the ***structure of language (syntax)*** are biologically determined and hence ***genetically transmitted***. He argued that all humans share the same underlying linguistic structure, irrespective of socio-cultural difference. **Universal grammar constraints syntactic diversity in humans** → the structure of language is common among different socio-cultural groups

In other words: genes constrain language diversity.

**Ofer Tchernichovski:
Do genes constrain song diversity?**



The City University of New York

Song culture in birds

- There are more than 4,000 species of songbirds
- Some songbirds provide biologically tractable models of culture: geographically separated groups have *local song dialects* just like humans.
- But *the variety is not infinite*: different species exhibit distinct song cultures, suggesting genetic constraints.

What happens when you isolate a bird from his father before the sensory period?

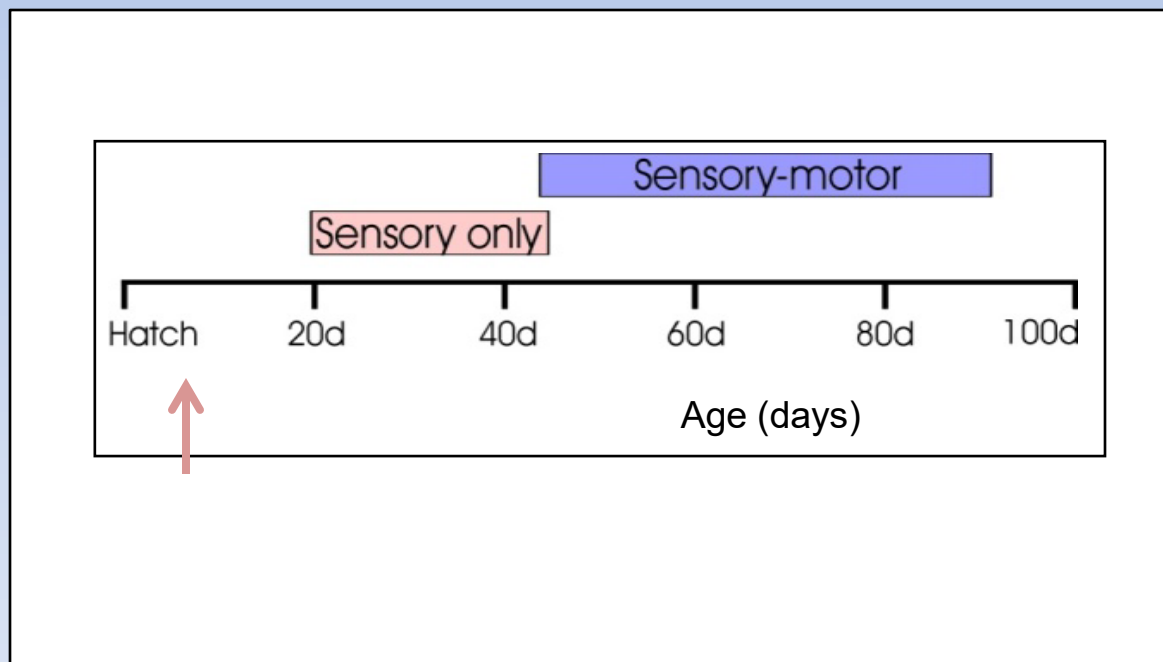

Can we rise a colony from isolates?

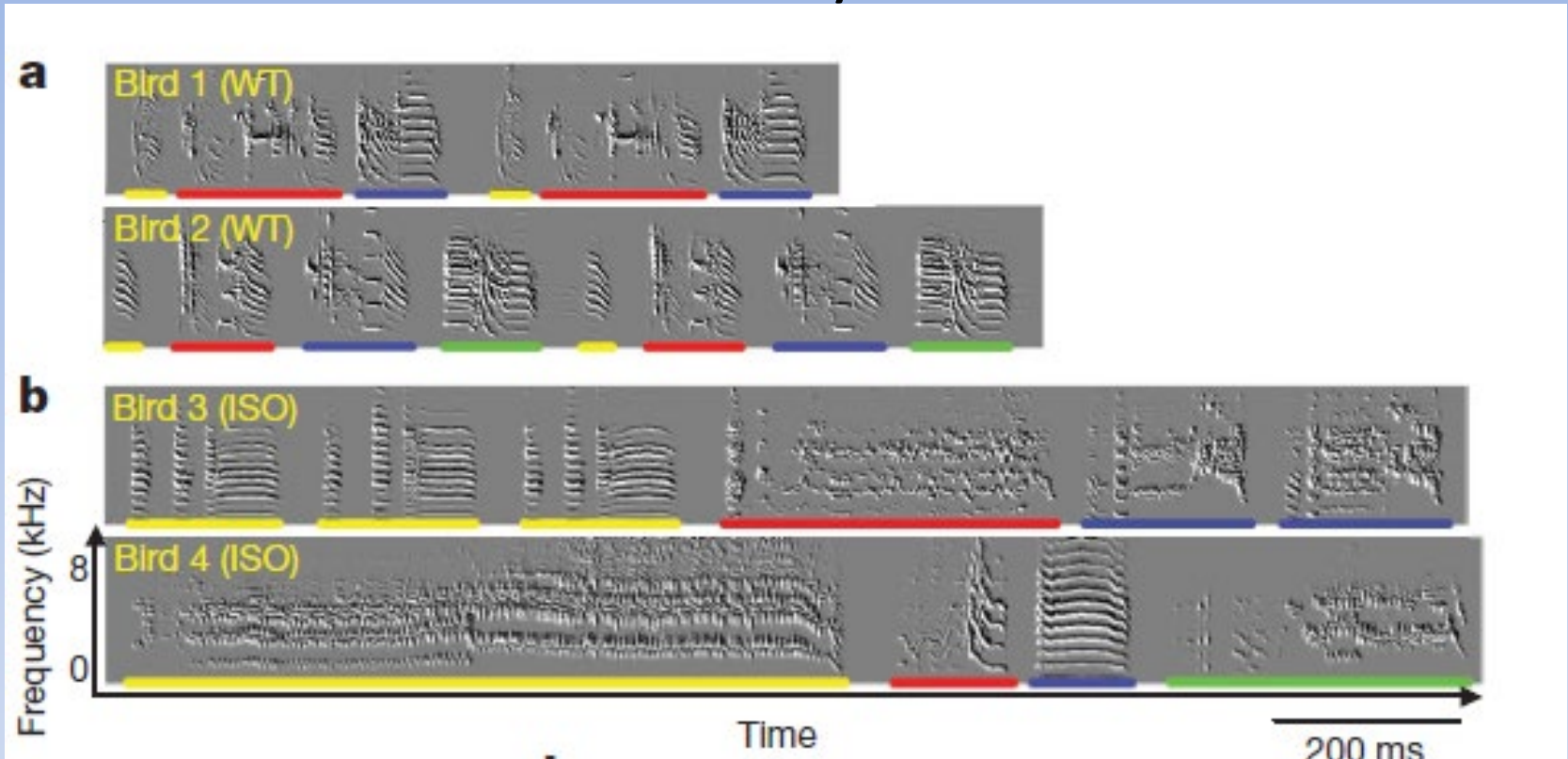

The experiment: to determine whether normal wild-type song culture might emerge over multiple generations in an isolated colony founded by isolates.

Konishi 1965; Marler 1970

Fehe´r et al. Nature 2009

The lab of Ofer Tchernichovski

Culture in the lab: development of song culture in the zebra finch

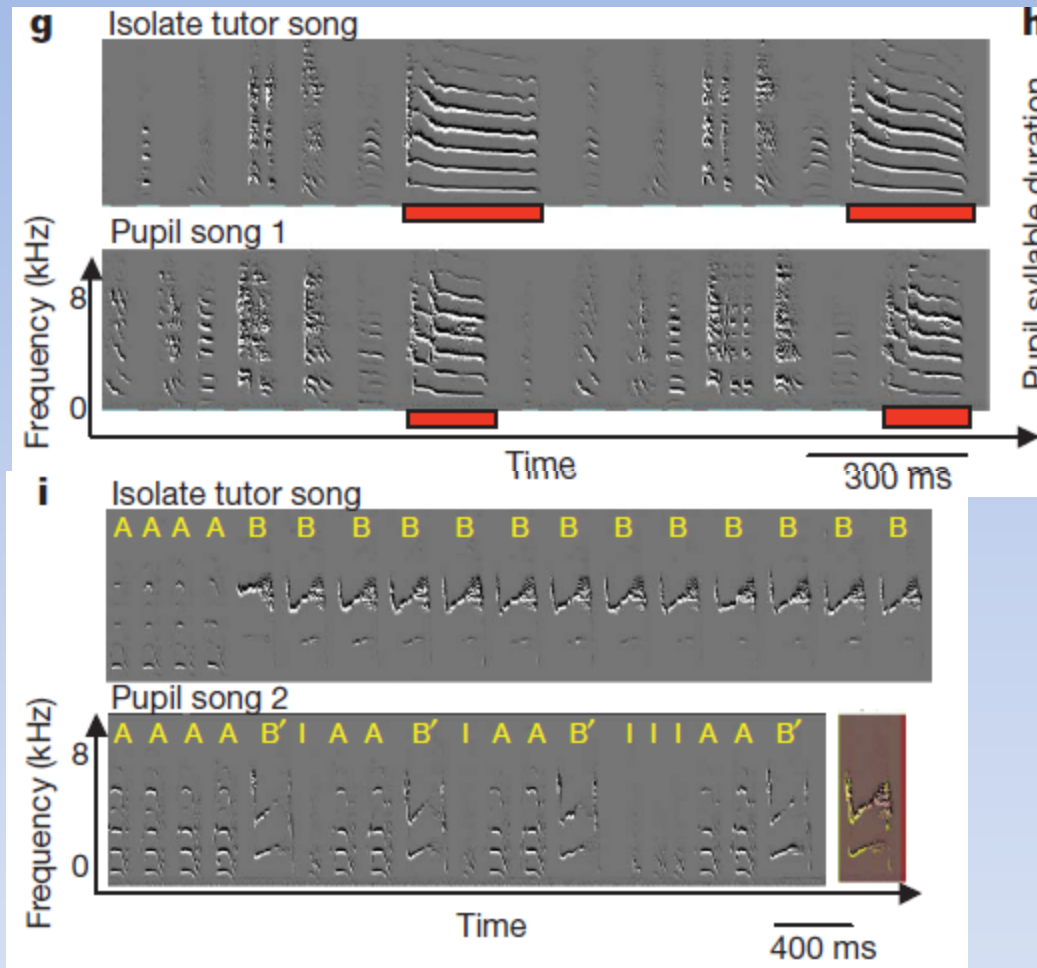

Fehe' r et al. Nature 2009
The lab of Ofer Tchernichovski

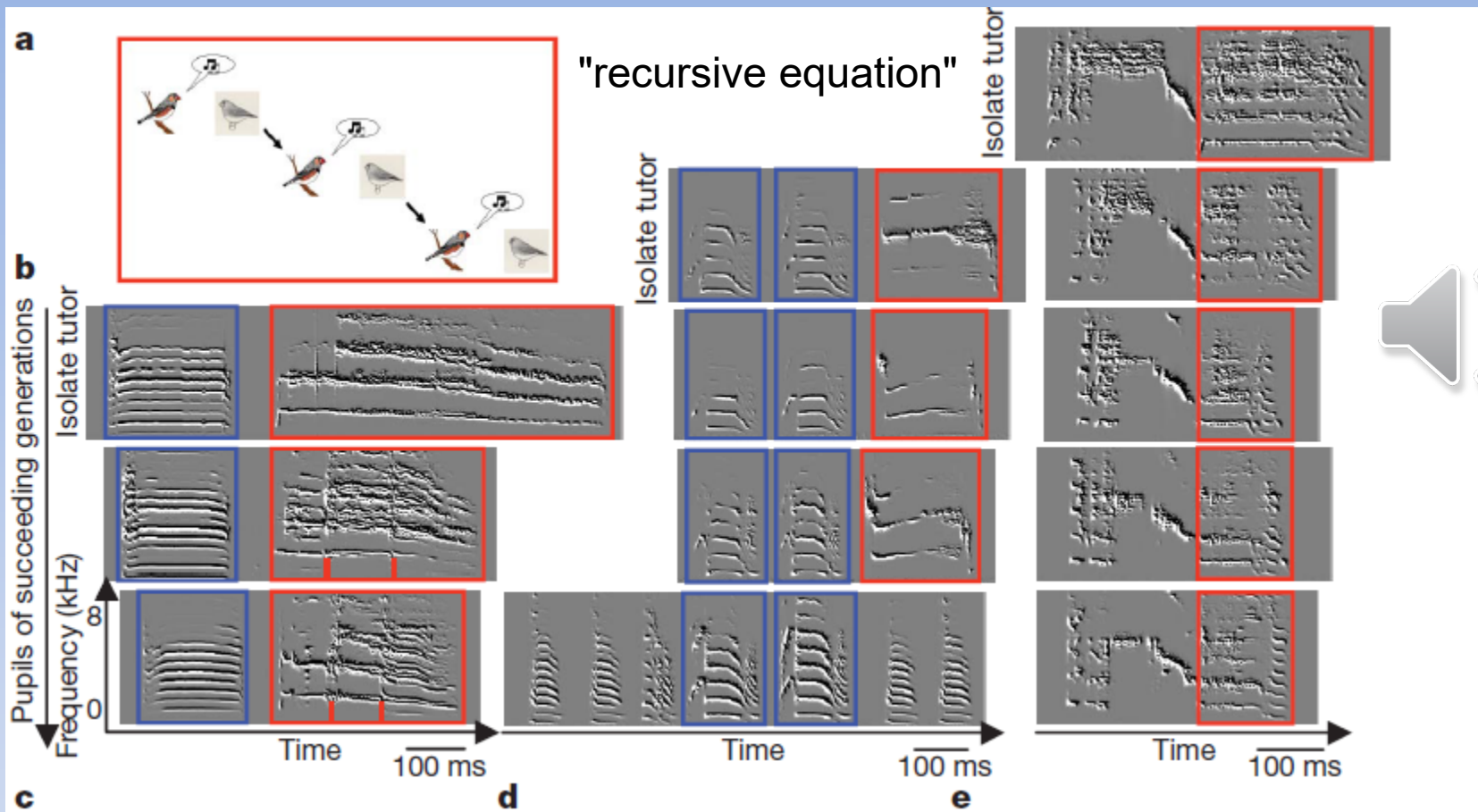

Song evolved towards the wild-type in three to four generations. Thus, species-typical song culture can appear *de novo*.

Fehe' r et al. Nature 2009
The lab of Ofer Tchernichovski

Juvenile zebra finches fostered by Bengalese finch learned Bengalese finch syllable morphology but not temporal gap timing.

Temporal gap coding is innate, whereas syllable coding is experience dependent.

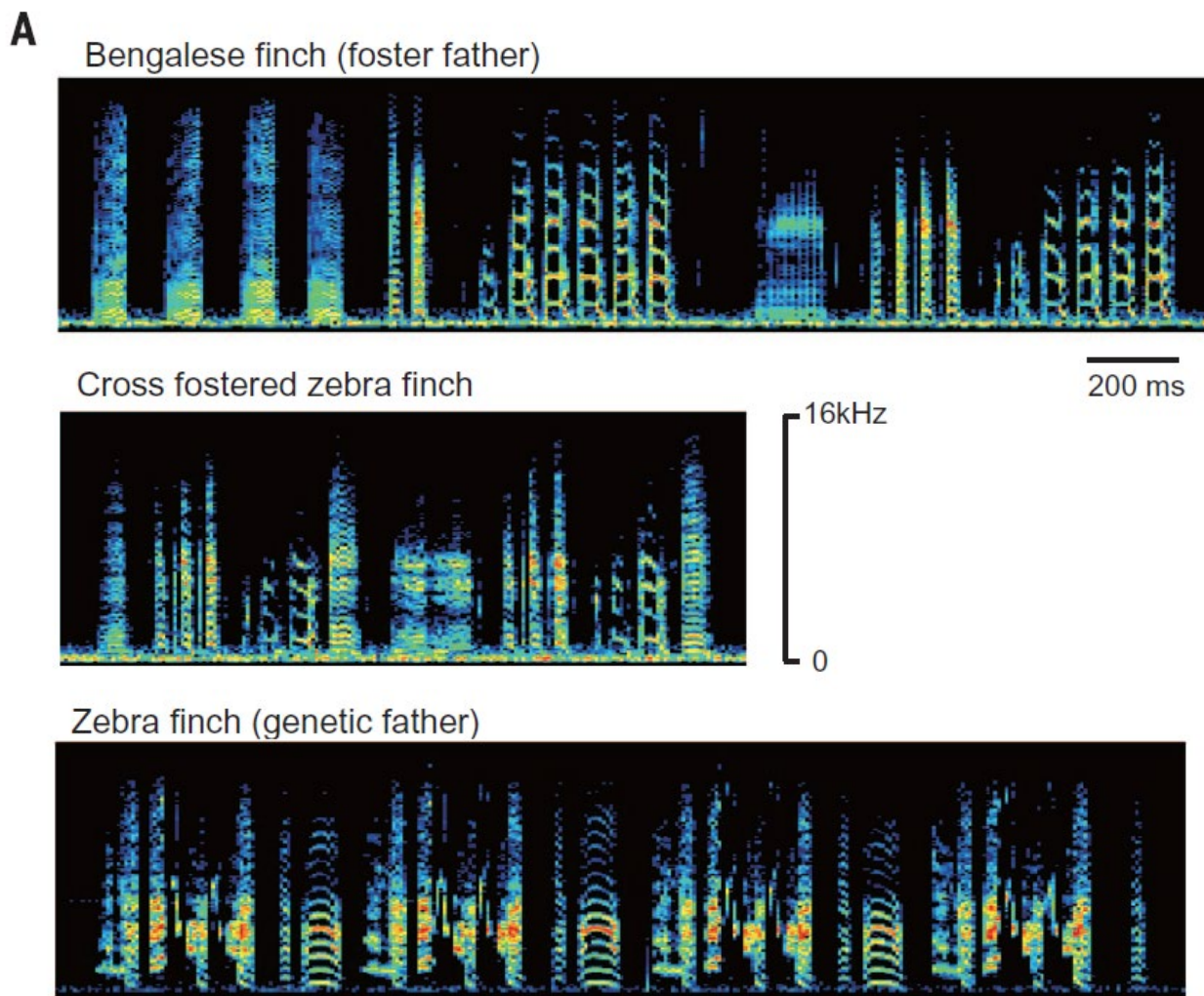

Mind the gap: Neural coding of species identity in birdsong prosody

Makoto Araki, M. M. Bandi, Yoko Yazaki-Sugiyama

Cross fostered zebra finches has similar temporal structure to zebra finch song but the spectral was of Bengalese

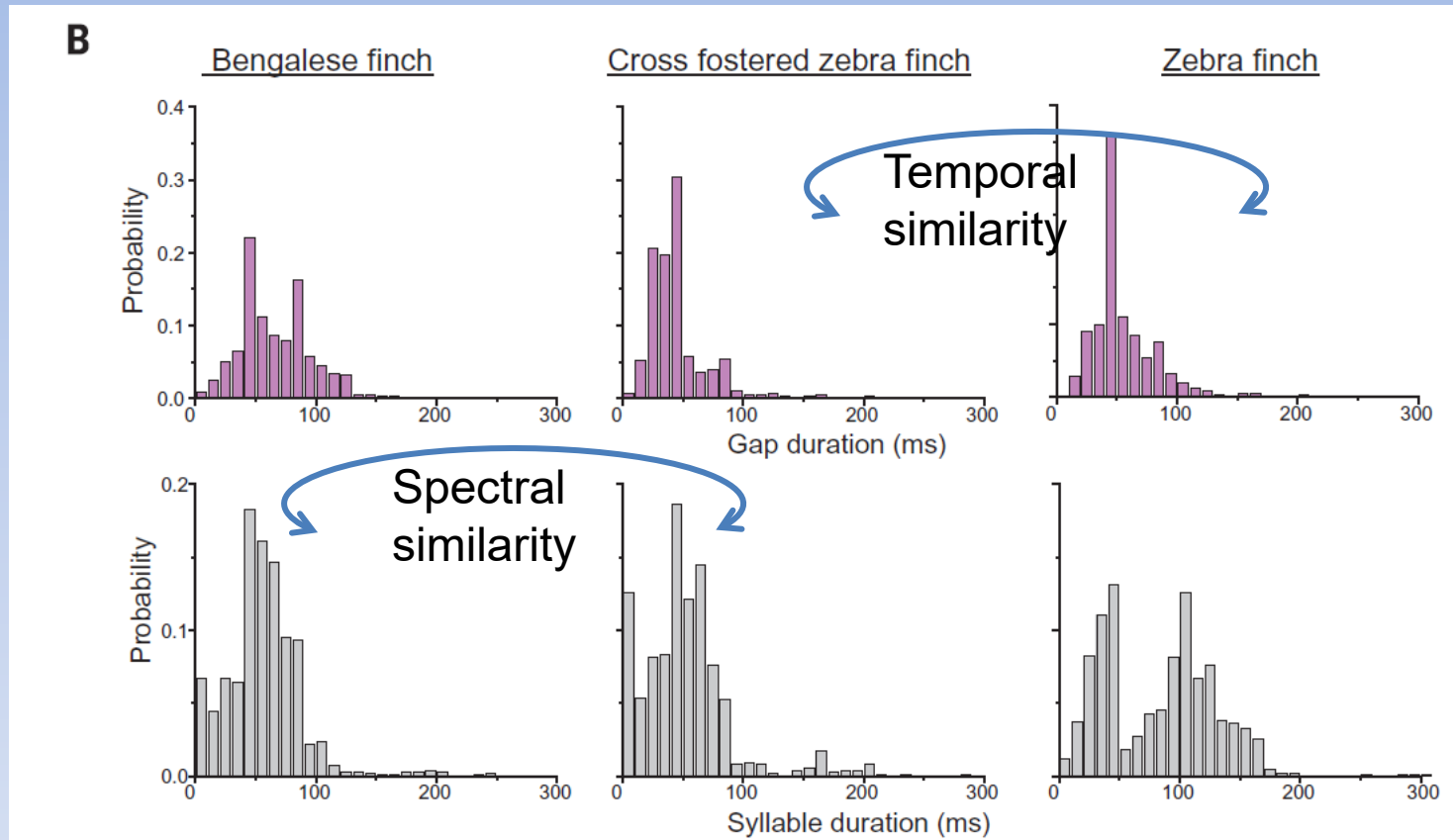

Chomsky: the *structure of language (syntax)* are biologically determined and hence *genetically transmitted*

Mind the gap: Neural coding of species identity in birdsong prosody

Makoto Araki, M. M. Bandi, Yoko Yazaki-Sugiyama

Summary

- Activity of the motor pathway is stereotyped.
- Activity of the learning pathway is variable.
- These two signals are combined at RA.
- Temporal gap coding (syntax) is innate, whereas syllable coding is experience dependent.

