

# Active sensing



**Ehud Ahissar**

## Active sensing

- Passive vs active sensing (touch)
- Comparison across senses
- Basic coding principles

-----

- Perceptual loops
- Sensation-targeted motor control
- Proprioception
- Controlled variables
- Active vibrissal touch: encoding and recoding

# Eye movements during fixation

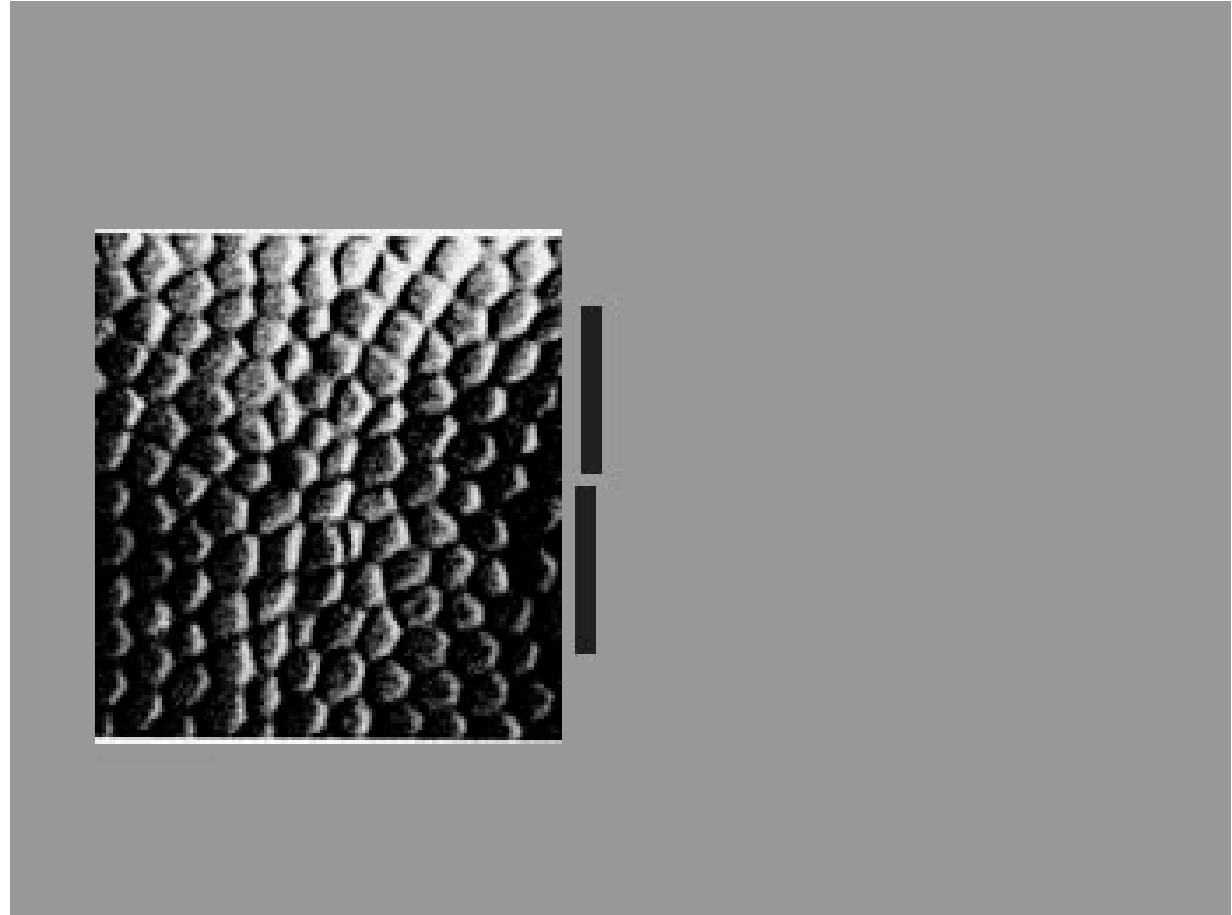
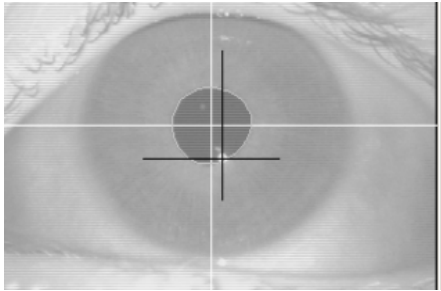

sensory encoding:

What receptors tell the brain

Sensory organs consist of **receptor arrays**:

**somatosensation**

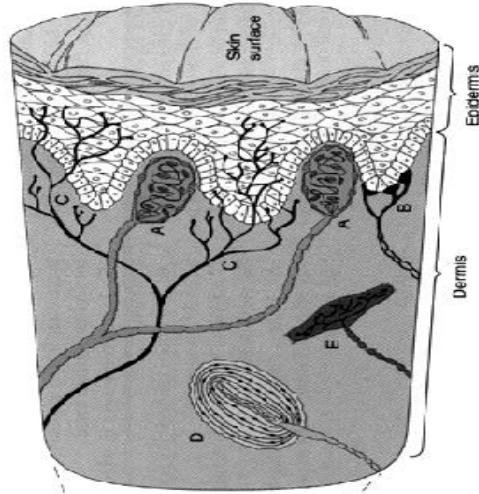

~200 μm

*Finger pad*

**audition**



10 μm

*cochlea*

**vision**

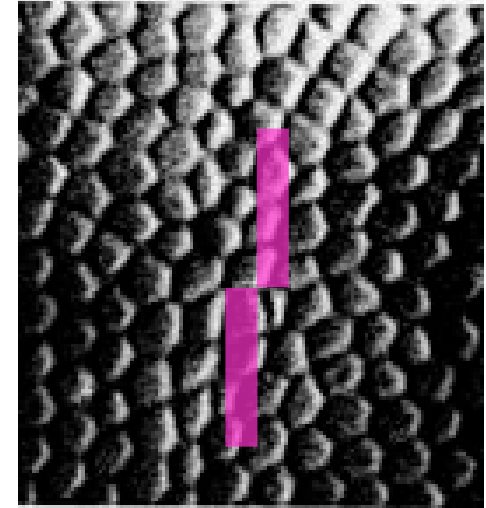

10 μm

*retina*

**Spatial organization => Spatial coding** (“*which* receptors are activated”)

**Movements => Temporal coding** (“*when* are receptors activated”)

# Temporal coding in action



# Coding space by time

1. Spatial frequency

2. Spatial phase

# Touch: Temporal encoding of spatial features

Darian-Smith & Oke,  
J Physiol, 1980

anesth. monkey,  
MR fibers

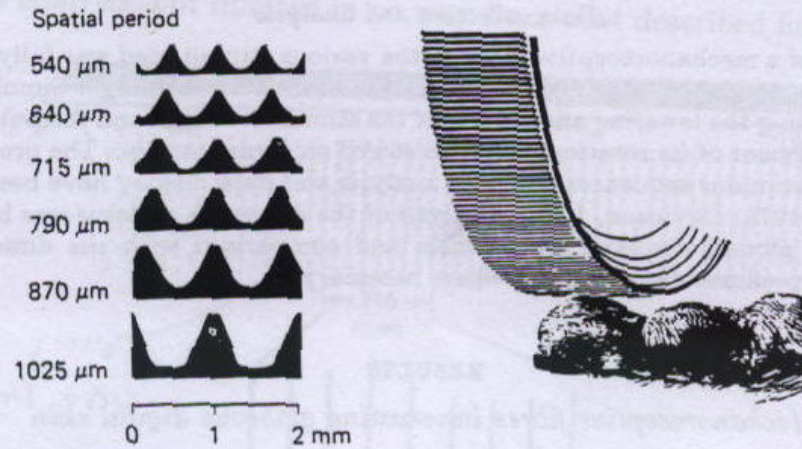

Fig. 1. Details of the stimulator used for presenting gratings to finger pad skin. The grating was mounted on a rotating drum 100 mm in diameter (upper right). The profile of each of the six gratings used is shown (upper left), along with its spatial period. The lower diagram illustrates the mechanisms for controlling the period of contact of the grating moving across the finger pad skin. The drum was mounted at one end of a counter-poised lever and rotated at a preset velocity. This drum was positioned 1 mm above the skin surface: an actuated solenoid held the drum off the skin except for the required contact period. The perpendicular force at which the moving grating was applied to the skin during this contact period was determined by the counter-weight: this could be set in the range 20–100 g wt.

# RA fiber

Vel - constant

$$f = SF * V$$

$$dt = dx / V$$

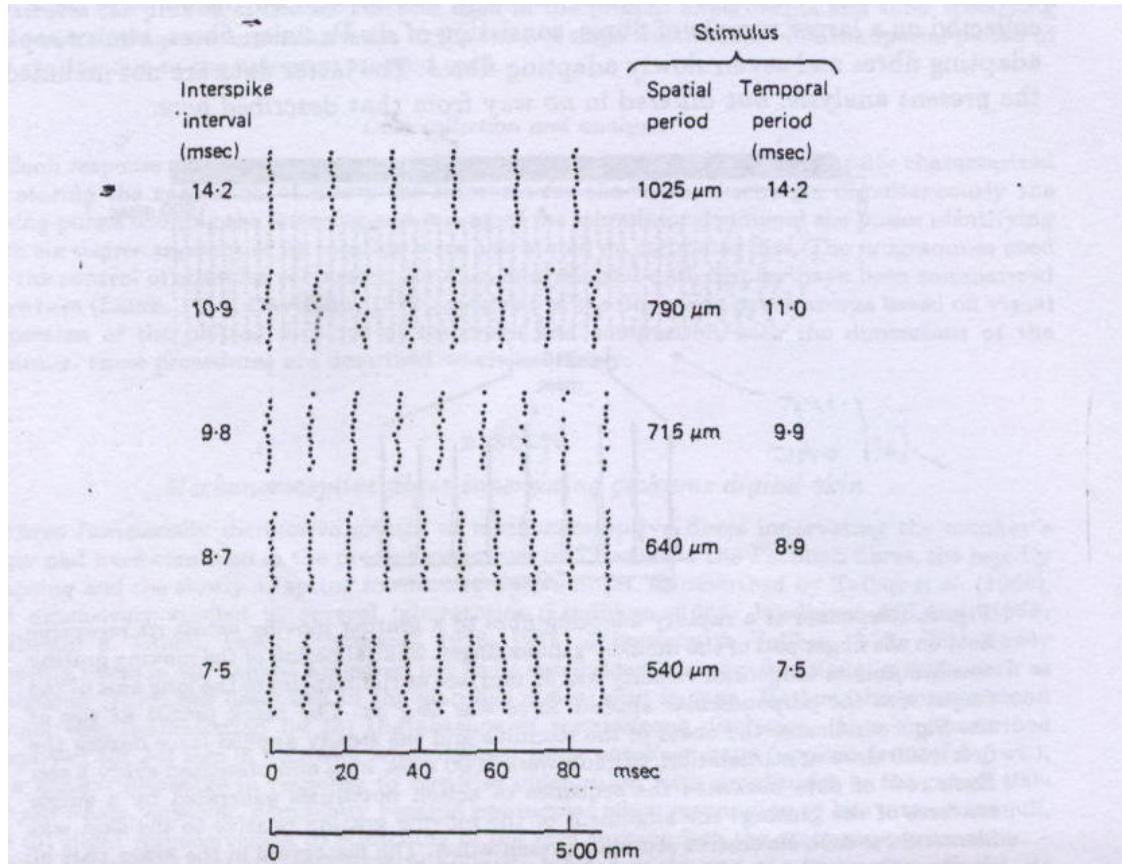
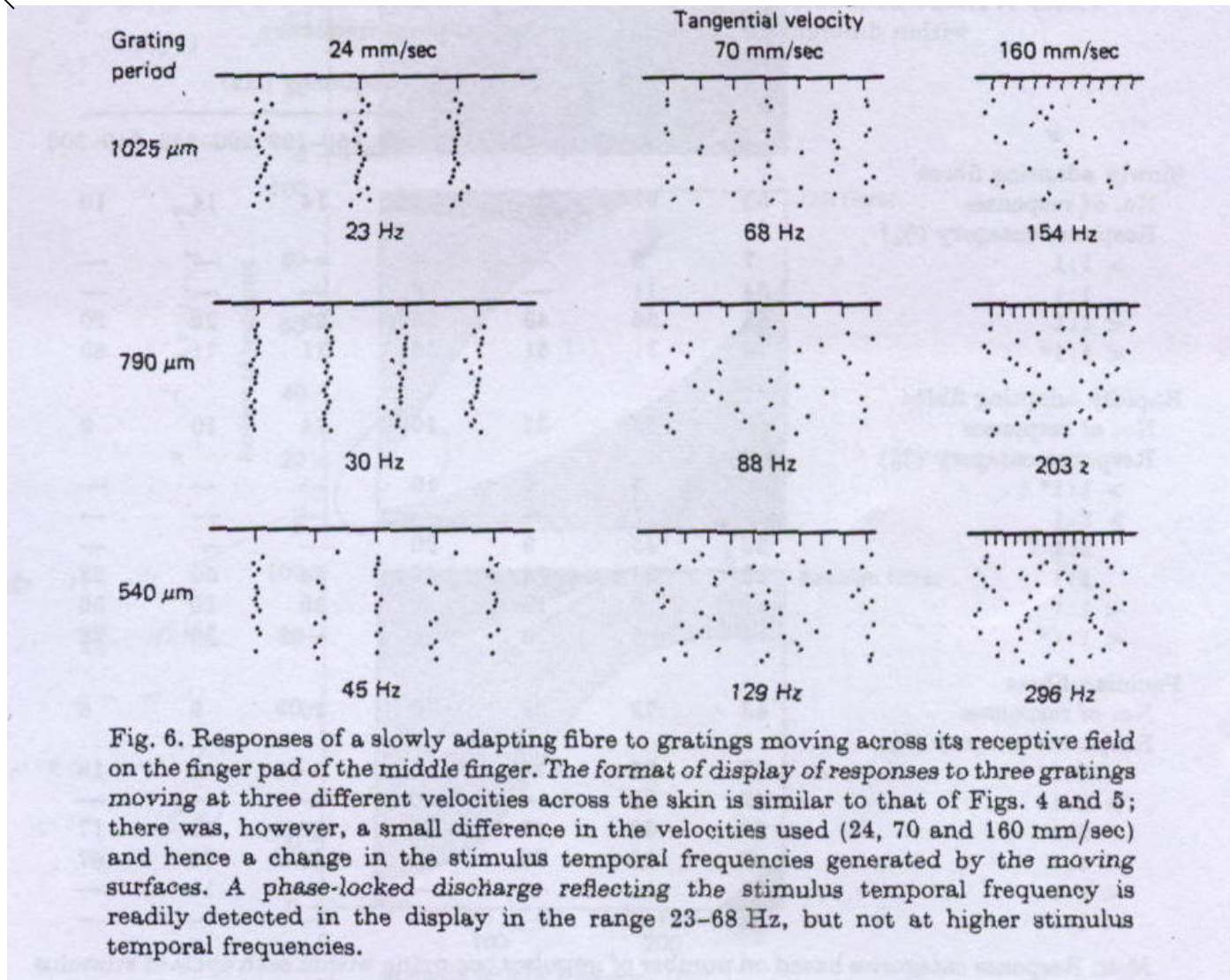

Fig. 3. Responses of a rapidly adapting fibre to different gratings moving across its receptive field on the ridged glabrous skin of terminal phalanx of thumb. The tangential velocity was 72 mm/sec in a direction at right angles to the long axis of the finger and the applied force was 60 g wt. for all records; successive stimuli were presented every 3 sec. Each row of dots indicates the occurrence of action potentials in response to a single passage of the grating across the skin; twelve successive responses are illustrated for each grating; spatial periods of these gratings are indicated on the right. The 80 msec response segment illustrated had its onset at approximately 500 msec after the beginning of stimulation, as is shown in Fig. 2. With these records there was both precise alignment of the time of occurrence of action potentials after the onset of stimulation, and also alignment relative to the instantaneous position of the grating on the skin. The stimulus spatial and temporal periods are indicated for each data block on right side of Figure. The mean interspike interval is to the left of each data block.

SF

Vel

## SA fiber



# RA fiber

SF \ Vel

SF

Vel

V1

V2

V3

G1

G2

G3

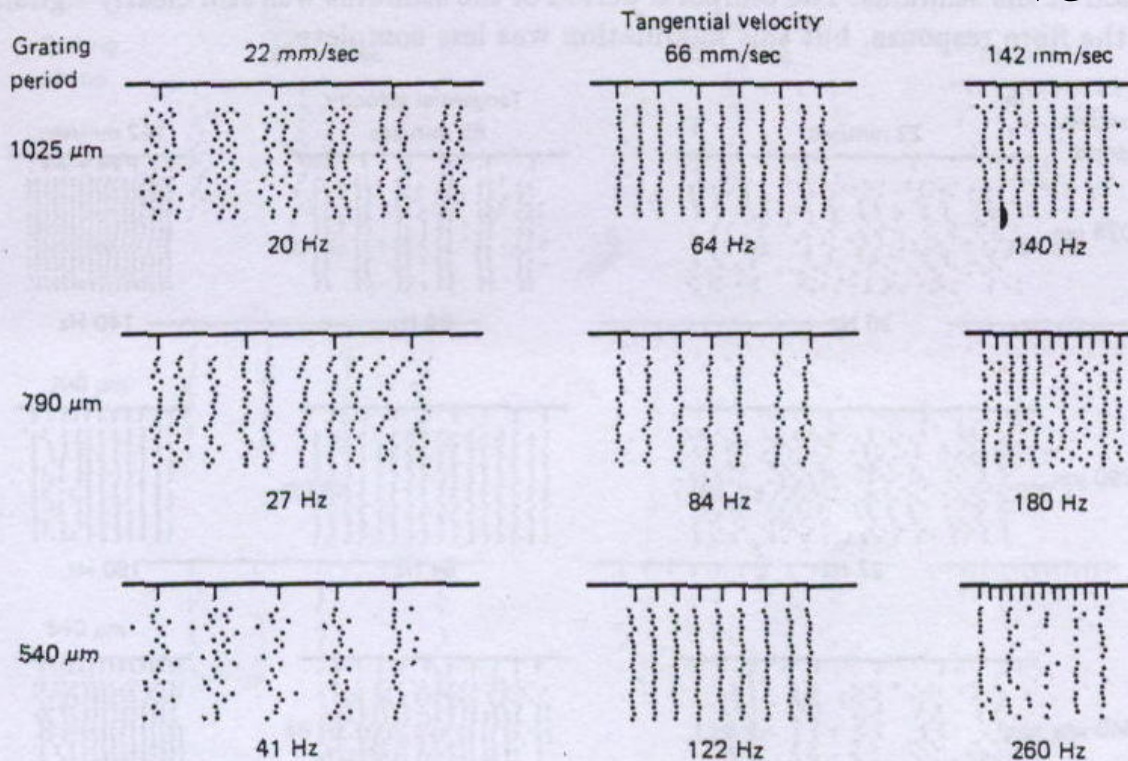

Fig. 4. Responses of a rapidly adapting fibre to three different gratings (spatial period of 1025, 790 and 540  $\mu\text{m}$ ) moving across the receptive field at three different velocities (22, 66 and 142 mm/sec). The fibre's receptive field was on the finger pad of the index finger. The radial force was 60 g wt. and contact area was approximately 5  $\times$  5 mm. Each response block is a segment of the response beginning approximately 500 msec after the onset of stimulation: other response and stimulus measures were as indicated in Fig. 3. The stimulus temporal frequency is indicated by the vertical bars above each response block, and its numerical value is stated below the block. The response frequency accurately reflected the stimulus frequency in the range 64–140 Hz. At frequencies below 64 Hz the stimulus temporal frequency was represented in the modulation of discharge but not in the mean discharge frequency; at stimulus temporal frequencies above 140 Hz, although the response was phase-locked to the stimulus, the fibre did not respond to each successive cycle of the stimulus and hence mean discharge frequency did not equal the stimulus temporal frequency.

SF / Vel

# PC fiber

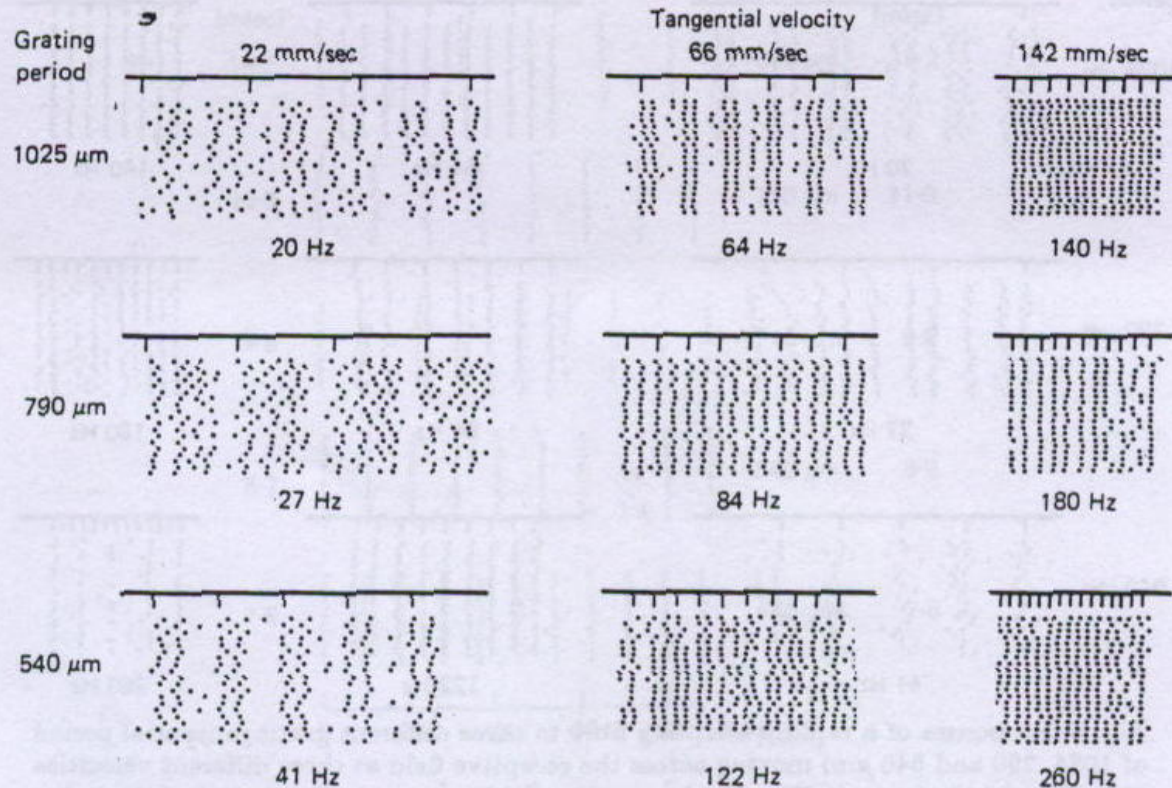

Fig. 5. Responses of a Pacinian fibre to gratings moving across part of its receptive field on the terminal pad of the index finger. The same combination of surfaces and velocities were used as in Fig. 4, and the display format is the same as in that Figure. Except with the lowest stimulus temporal frequencies (upper left corner) the fibre's response was modulated with a cycle period matching the temporal period of the stimulus. However only with stimulus temporal frequencies of 180 Hz or higher did the interspike interval match the stimulus temporal period (right column of the response blocks). In the stimulus temporal frequency range 64–140 Hz the fibre usually fired in phase twice per stimulus cycle, and at lower frequencies up to 5–7 spikes occurred within each stimulus temporal cycle.



# Temporal filtering (by intrinsic factors)

eye

whisker

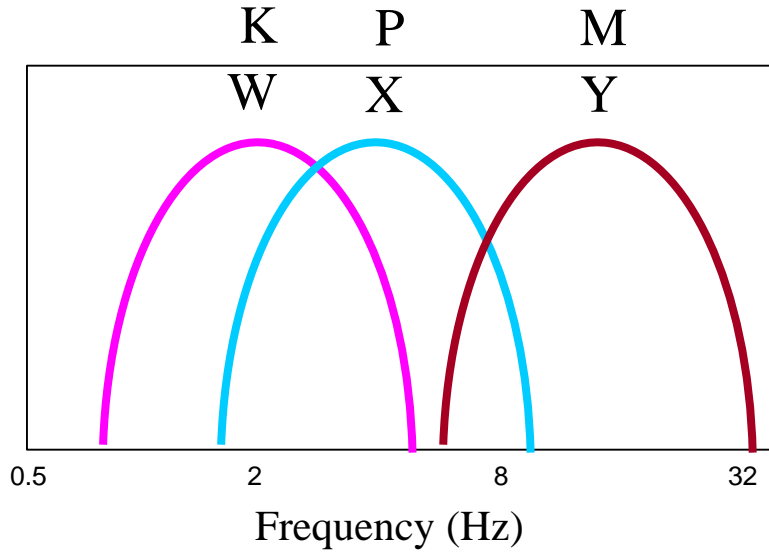

finger

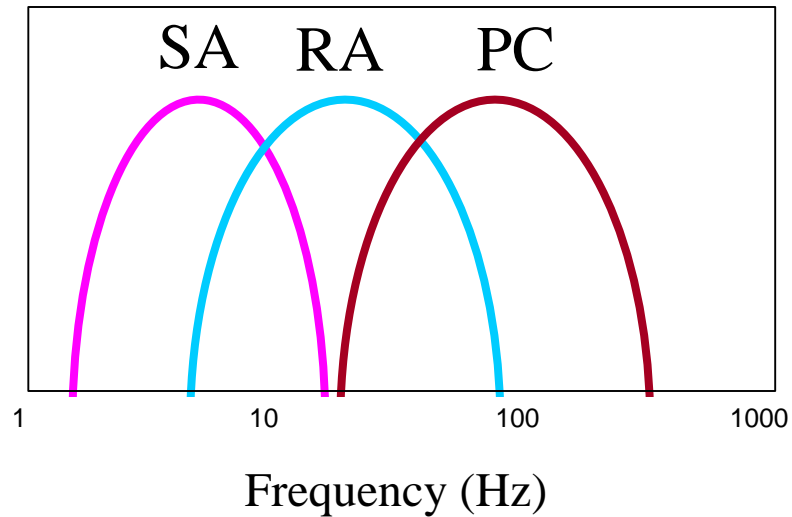

# Coding space by time

1. Spatial frequency

2. Spatial phase

# Vision: Temporal encoding due to eye movement

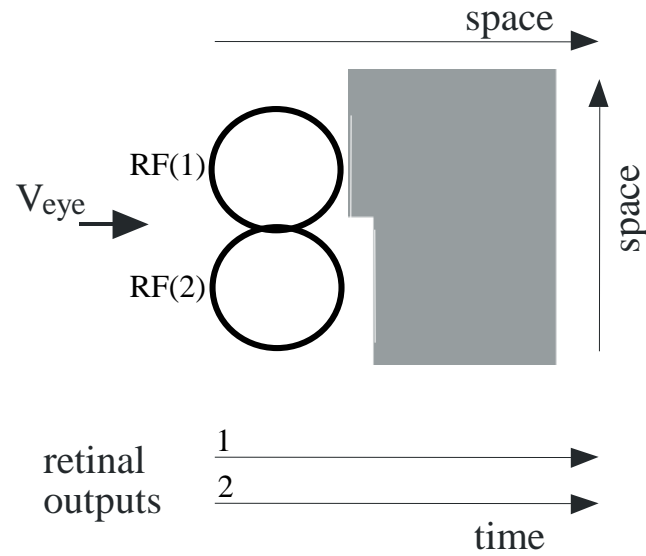

# Vision: Temporal encoding due to eye movement

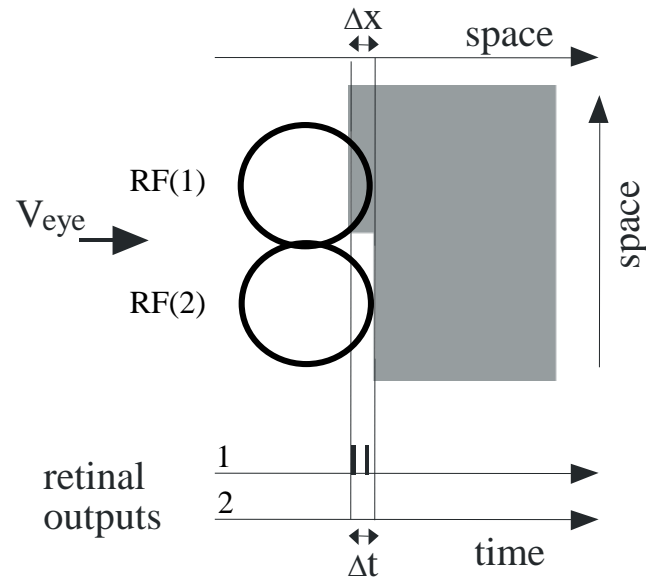

# Vision: Temporal encoding due to eye movement

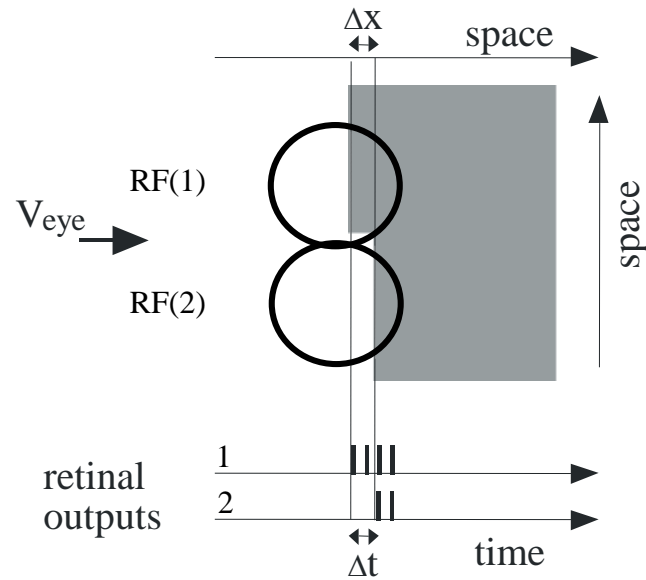

# Vision: Temporal encoding due to eye movement

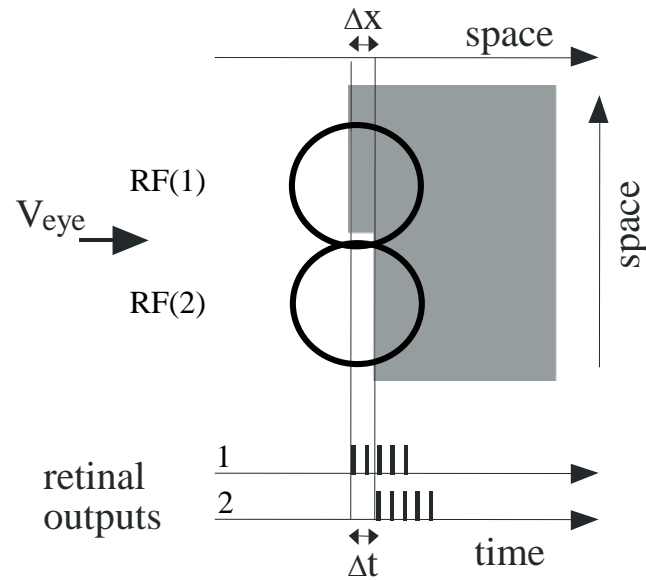

# Vision: Temporal encoding due to eye movement

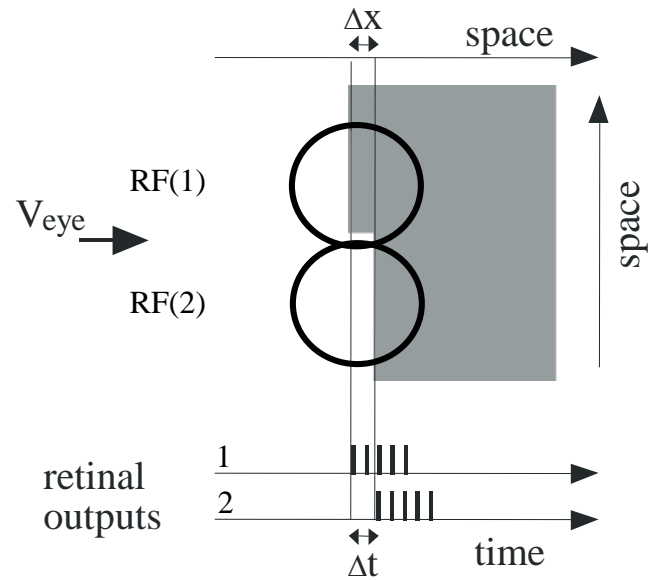

## Spatial vs temporal coding

<b>Spatial</b>	<b>Temporal</b>
faster	
	better resolution

- scanning allows sensing in between receptors

# Passive vs Active sensing

## of stationary objects

	<b>Passive</b>	<b>Active</b>
<b>threshold</b>	<i>low</i>	<i>high</i>
<b>accuracy</b>	<i>low</i>	<i>high</i>
<b>Systems involved</b>	<i>sensory</i>	<i>Sensory + motor</i>
<b>coding</b>	<i>spatial</i>	<i>Spatial + temporal</i>
<b>Processing speed</b>	<i>fast</i>	<i>slow</i>
<b>Used in</b>	<i>detection</i>	<i>Exploration Localization Identification ...</i>

# Central processing of touch

where touch begins?

Text book: at the receptors

# Sensory-motor loops of the vibrissal system

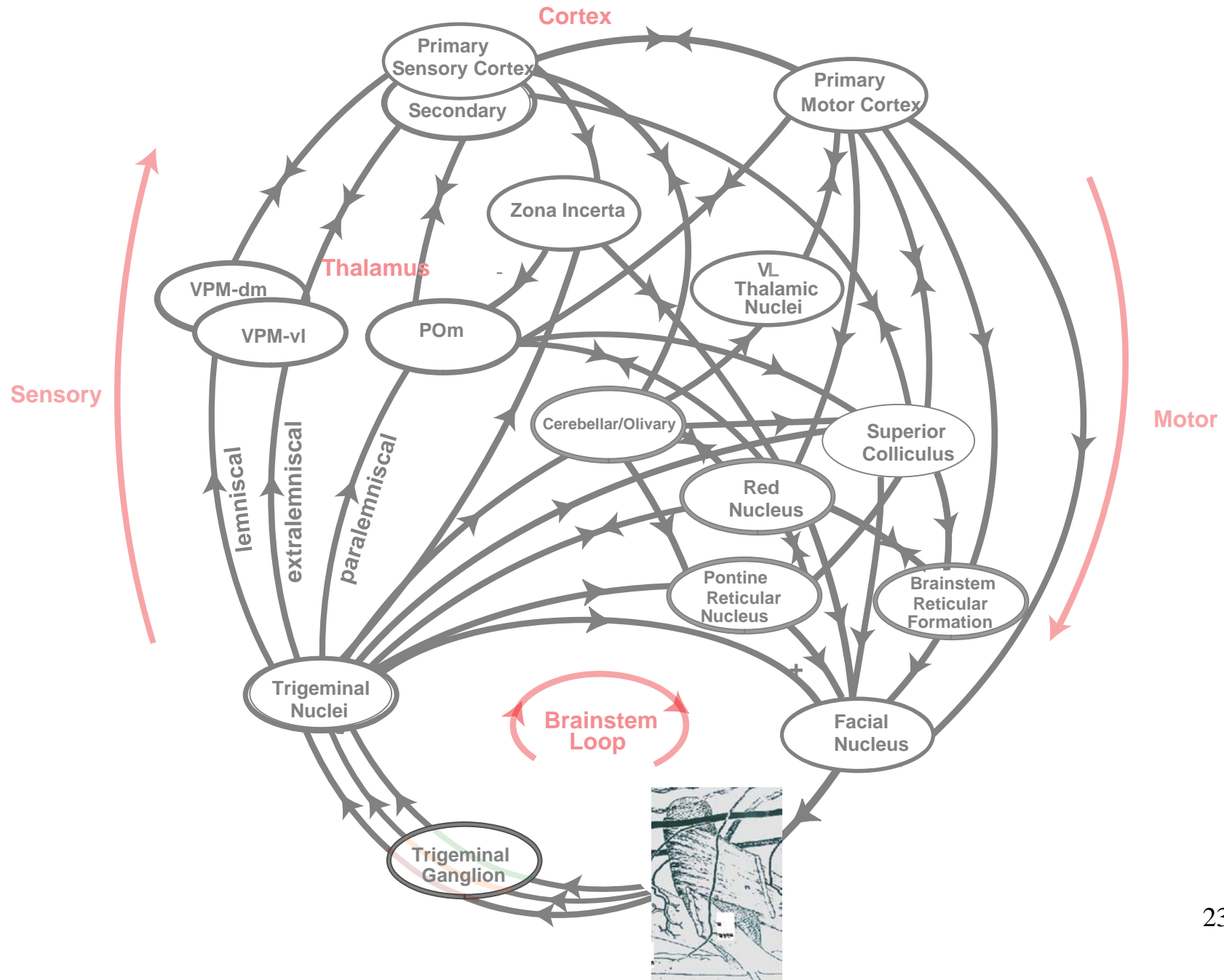

Sensory-motor loops of the vibrissal system

The old view

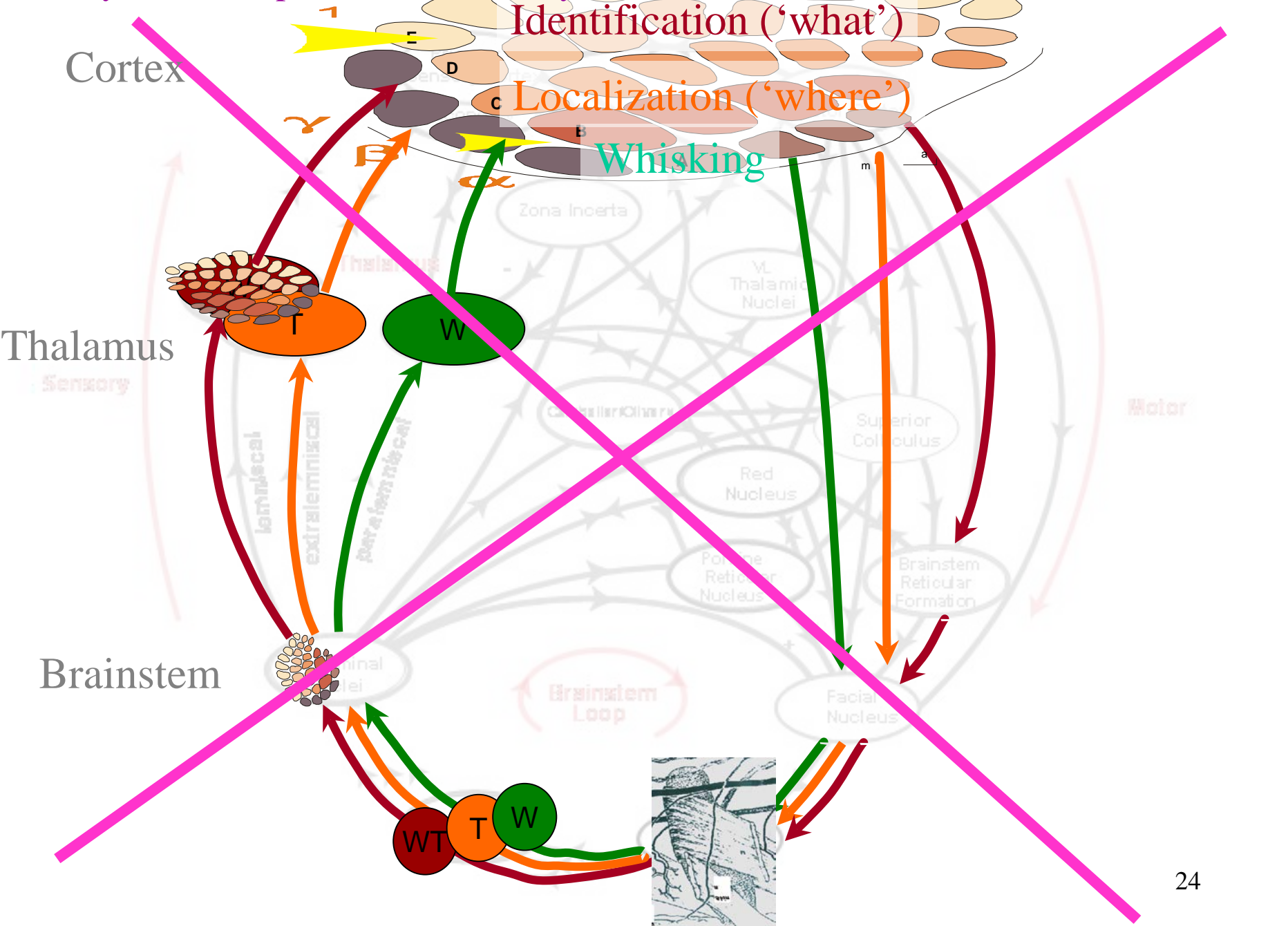

# Sensory-motor loops of the vibrissal system

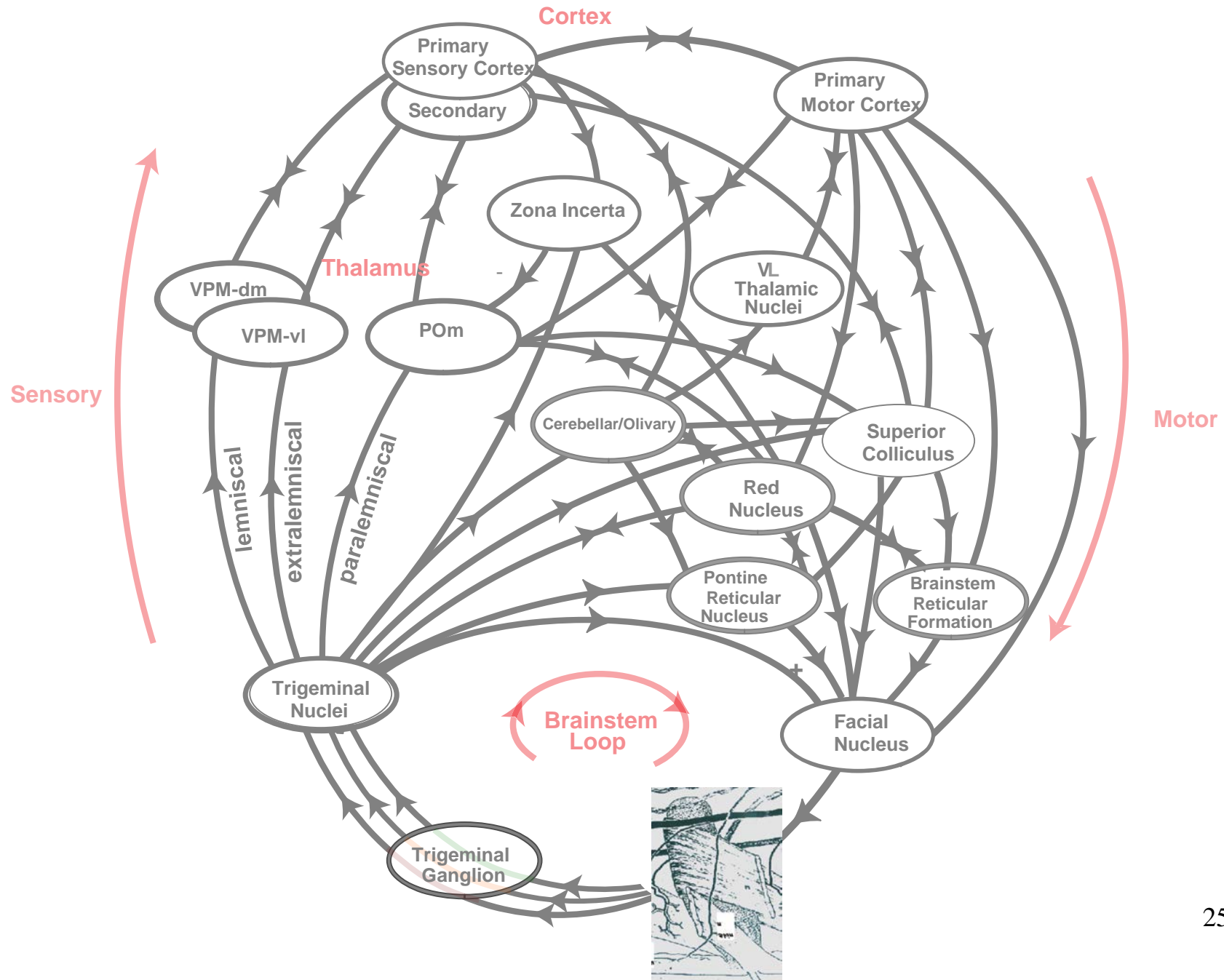

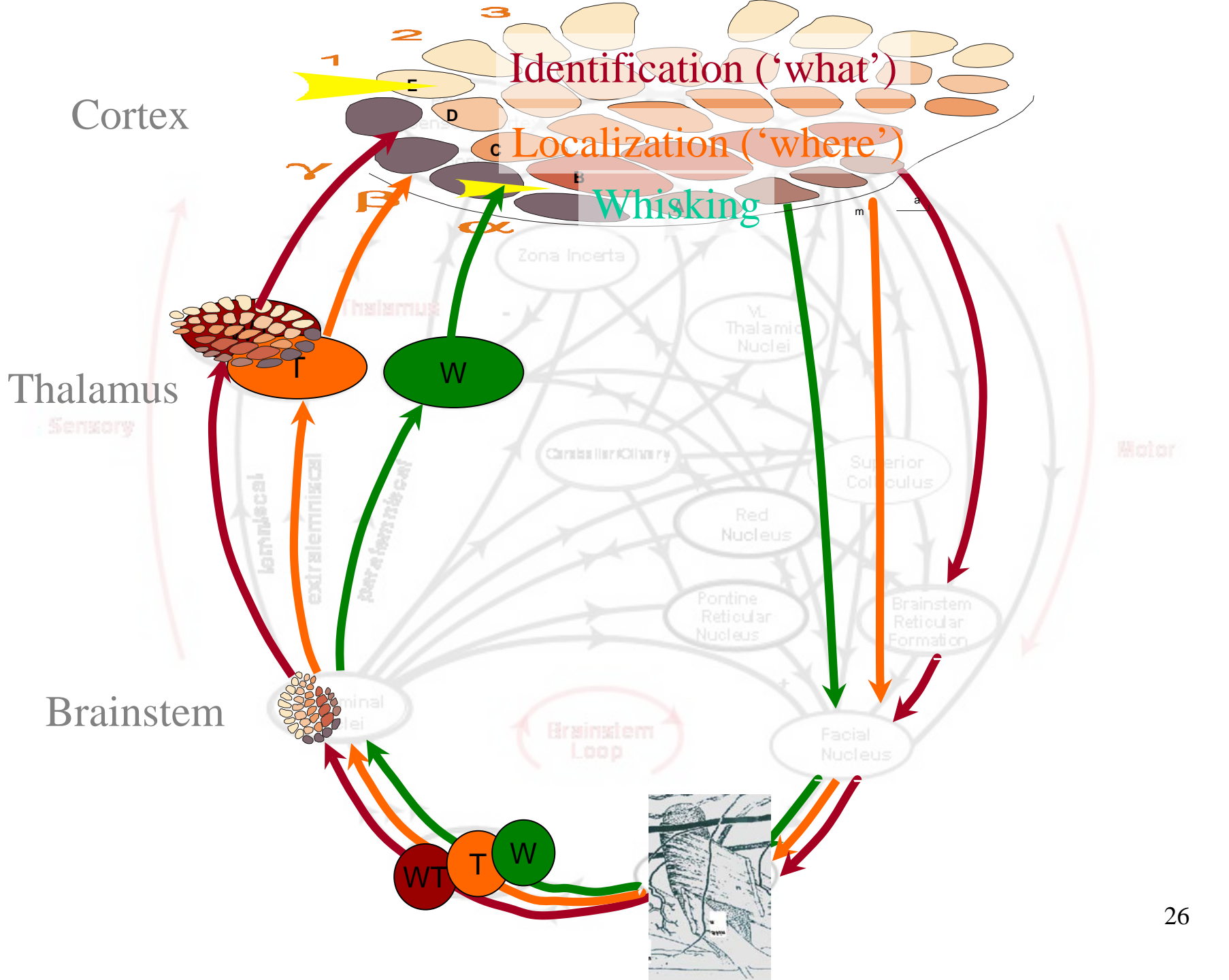

# Sensory-motor loops of the vibrissal system

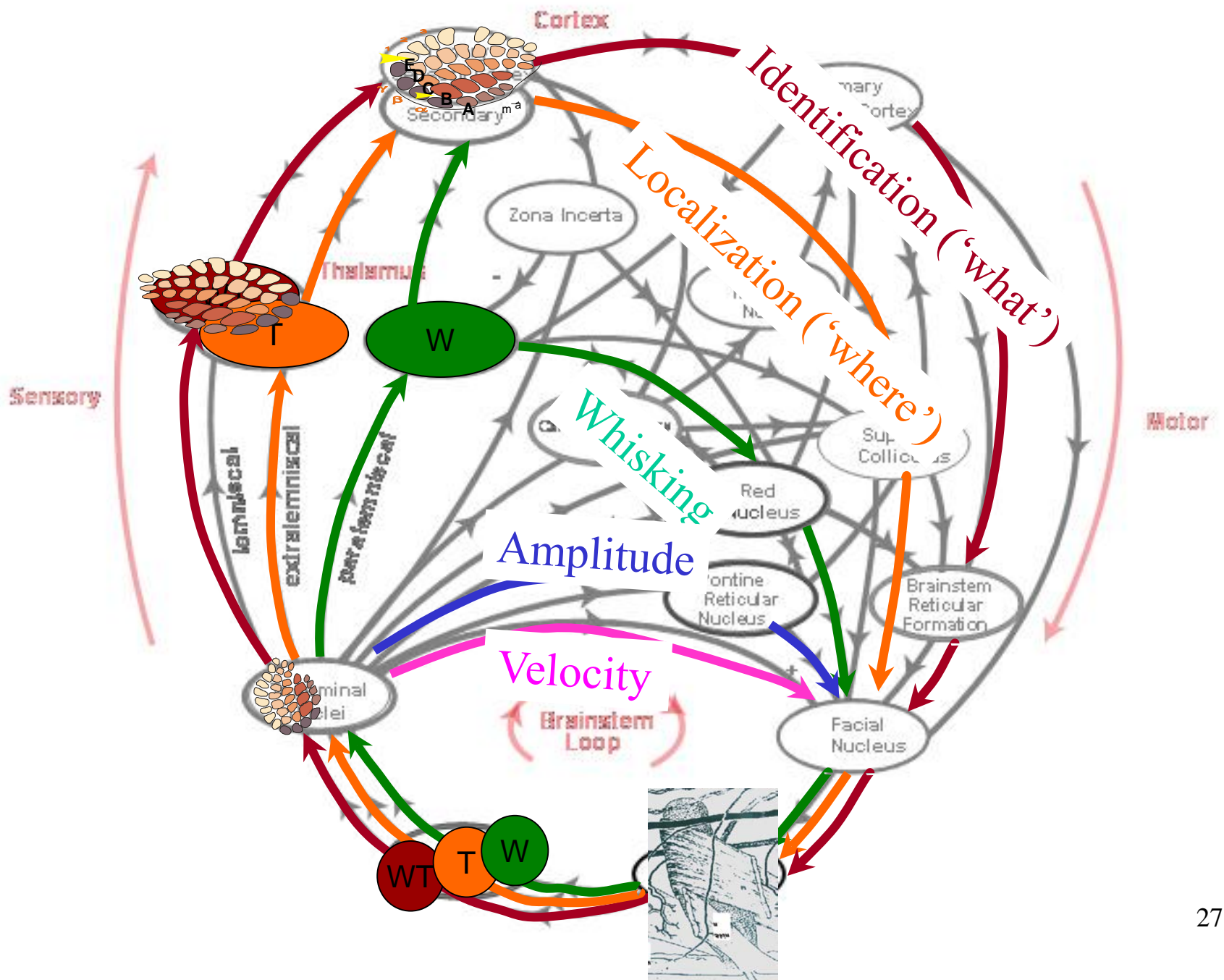

# Central processing of touch

where touch begins?

Text book: at the receptors

Active touch does not begin at the receptors

Sensor motion determines the interaction between the receptors and external objects

- Break ?

# Motor control

- Closed loops
- Proprioceptive feedback
- Reflexes – tool for probing loop function
- Controlled variables – motor vs sensory

# Motor control

- Closed loops
- Proprioceptive feedback
- Reflexes – tool for probing loop function
- Controlled variables – motor vs sensory

# Excitation Contraction Coupling

Phase 1:  
Firing of Motor Neuron

Phase 2:  
Release of Neurotransmitter

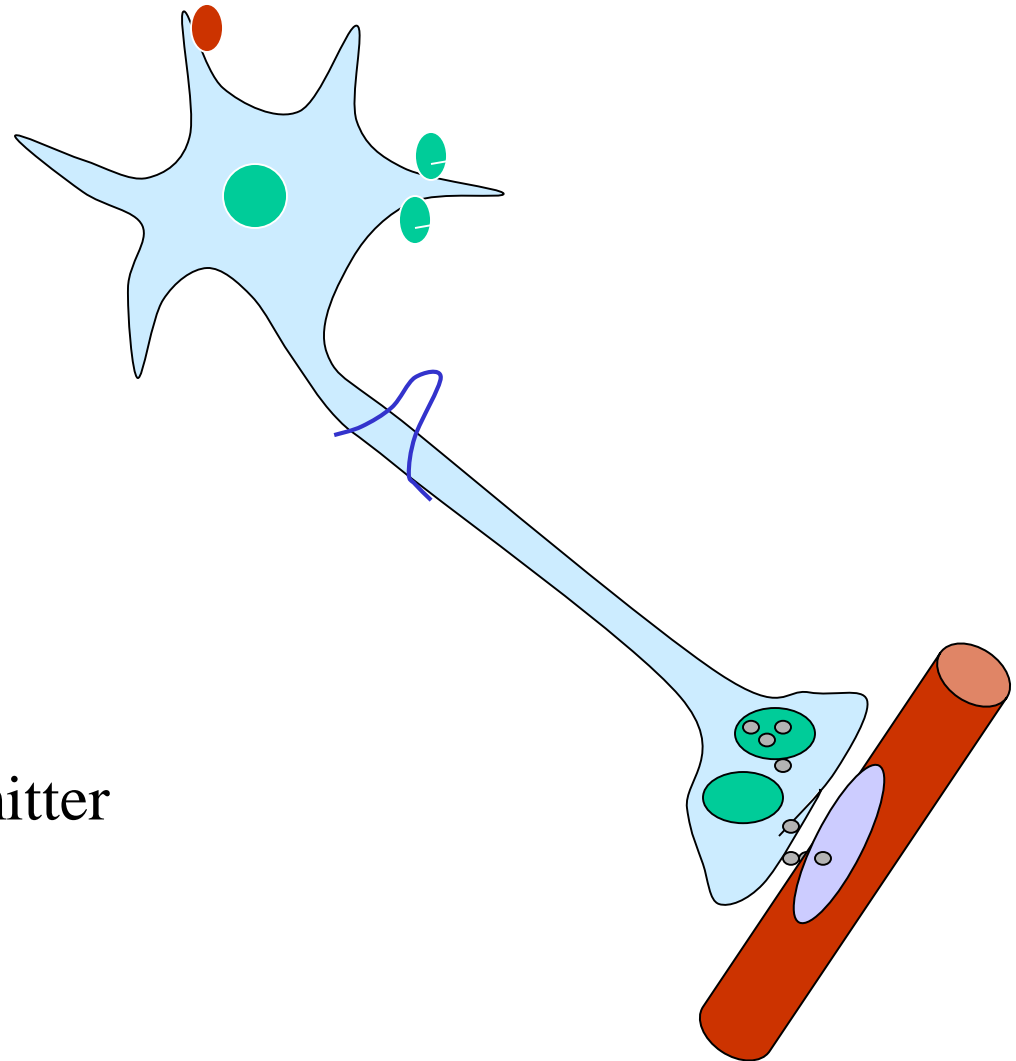

# Excitation Contraction Coupling

Phase 1:  
Firing of Motor Neuron

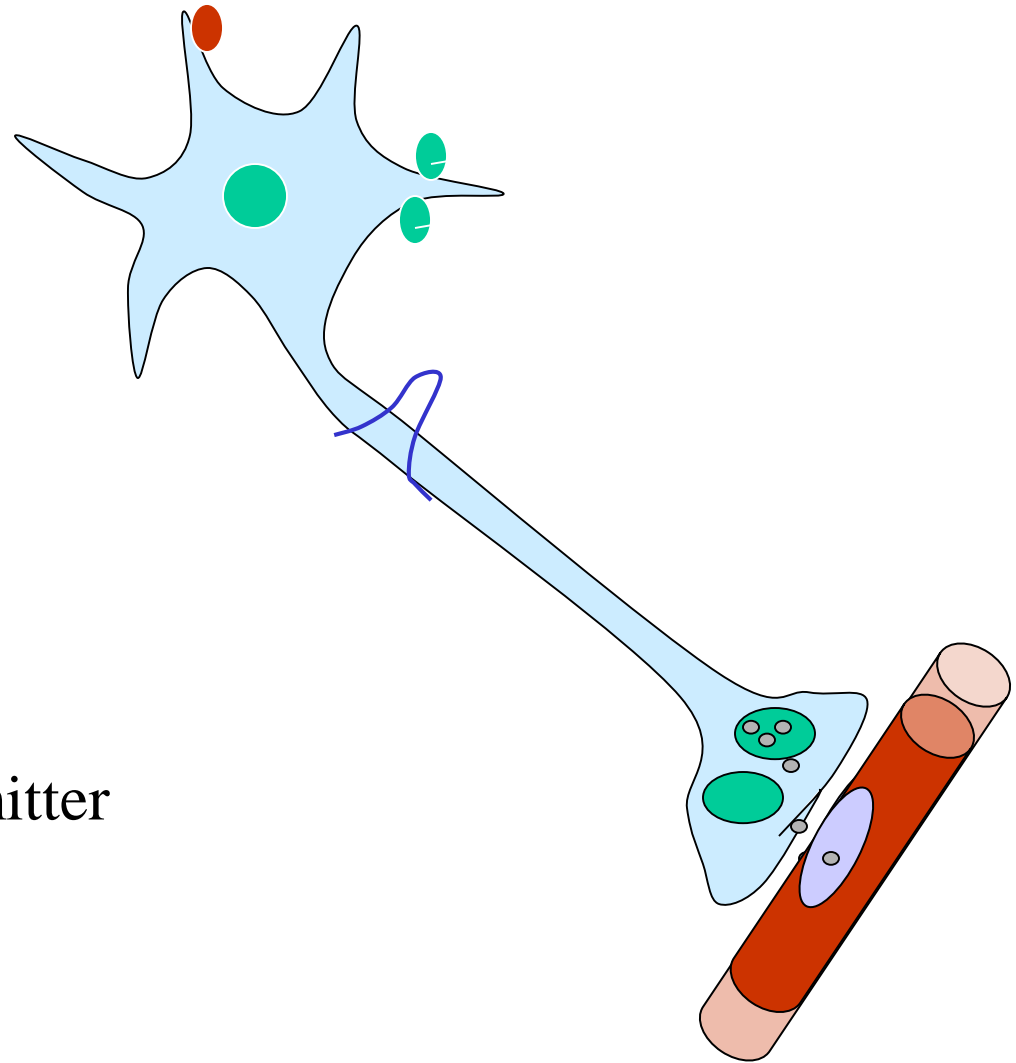

Phase 2:  
Release of Neurotransmitter

Phase 3:  
Muscle contraction

# Open-loop system

Information flows  
in one direction  
(from neurons to  
muscles)

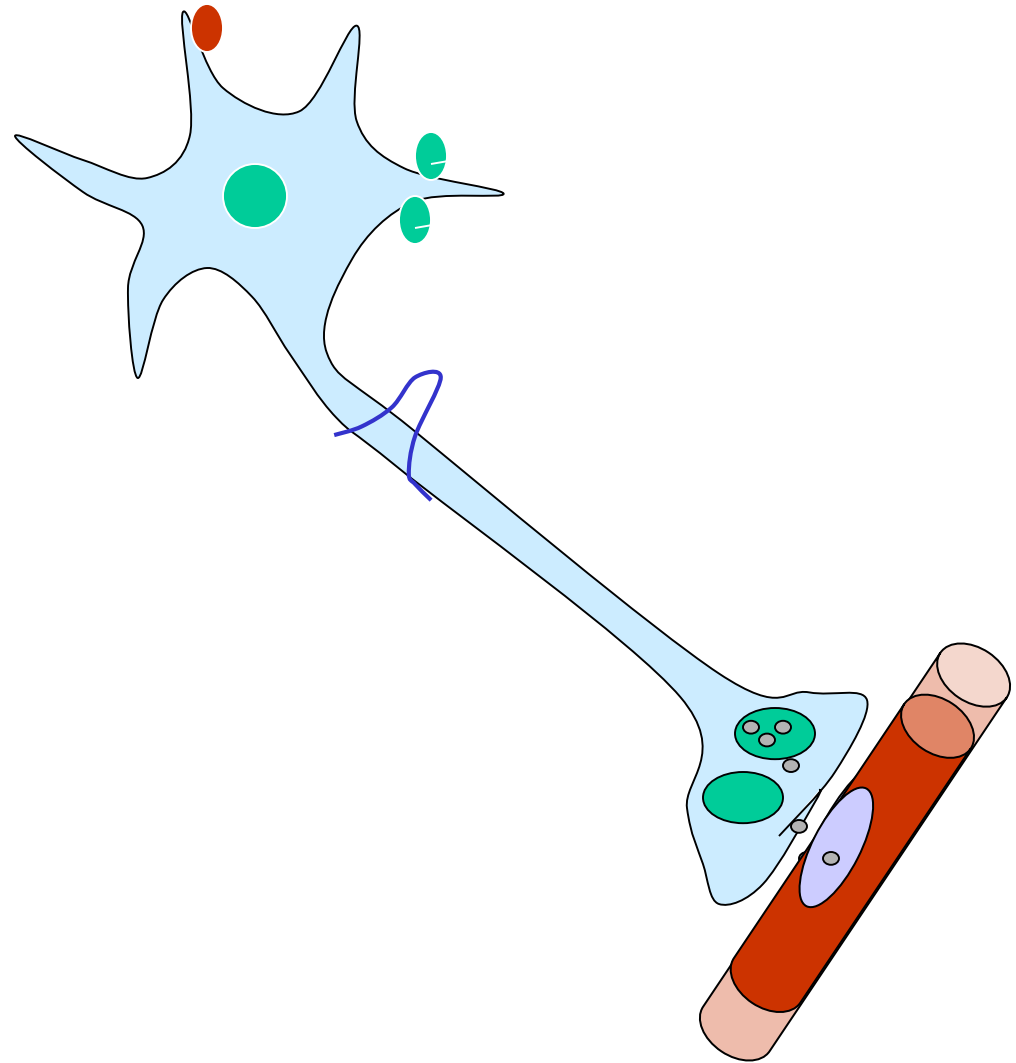

# Open-loop system

Information flows in one direction (from neurons to muscles)

# Closed-loop system

Information flows in a closed loop: from neurons to muscles and from muscles to neurons

What kind of information ?

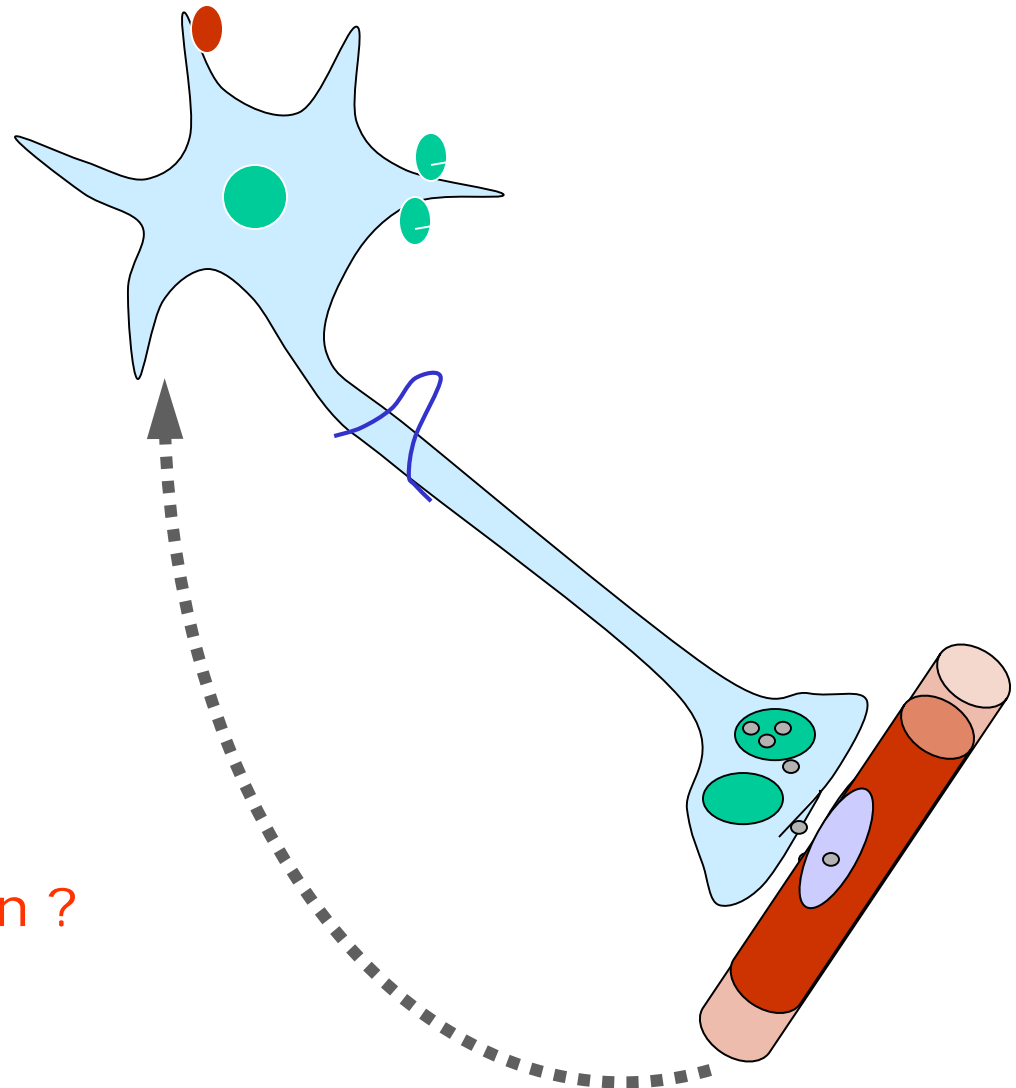

# Closed-loop system

The direct feedback from muscles and joints is mediated by **proprioceptive signals**

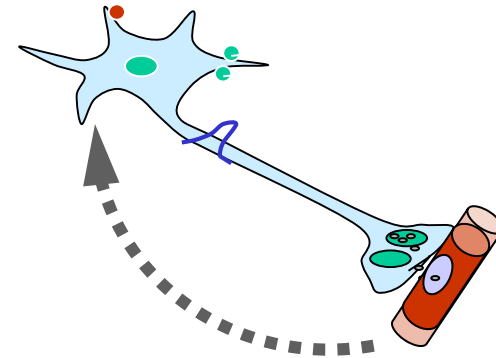

## Proprioceptive receptor types

Name:

Muscle spindle receptors

Golgi tendon organs

Joint receptors

Sensitive to:

muscle length

muscle tension

Flexion, extension

# Proprioceptive receptor types

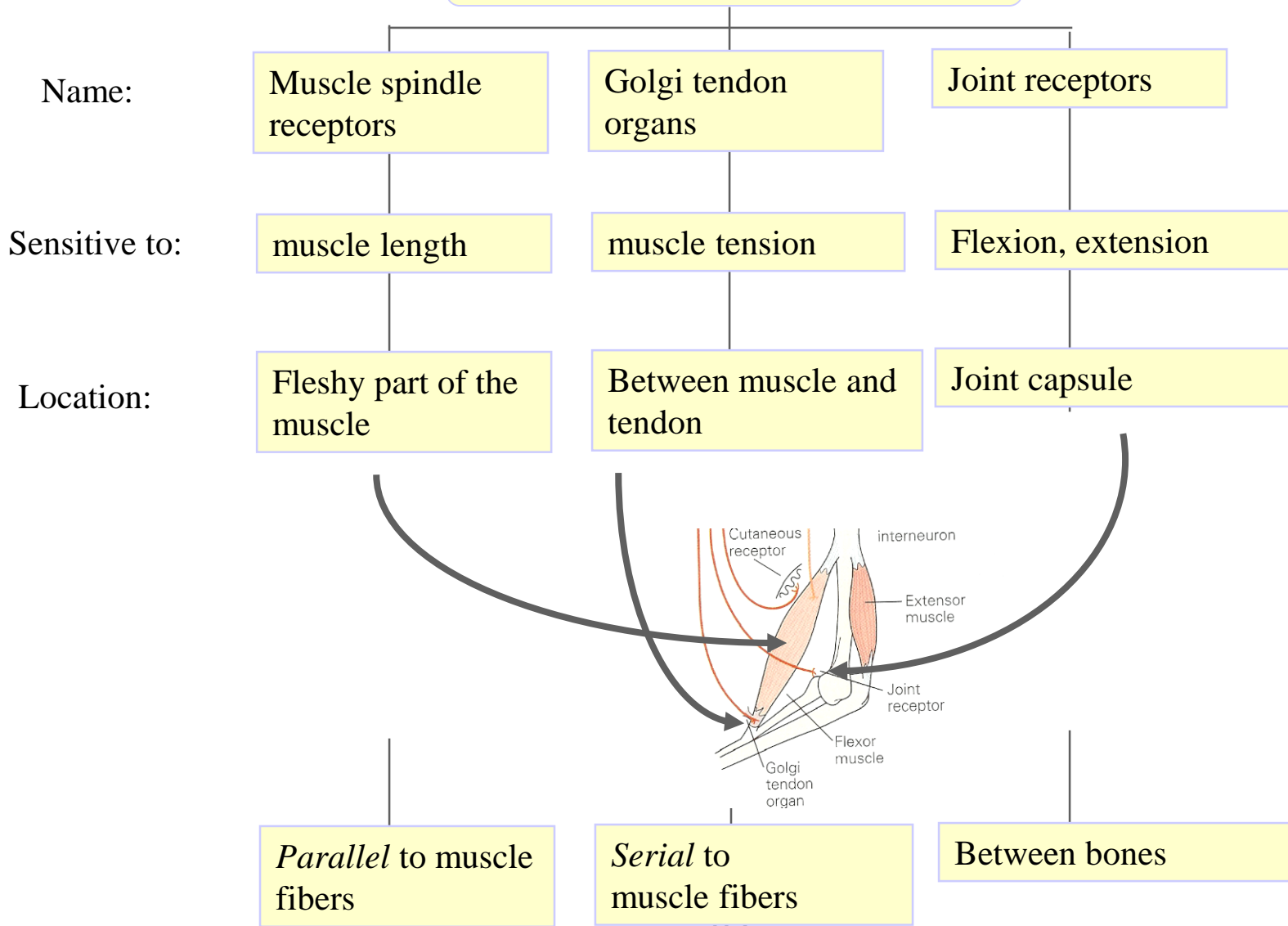

# Motor control

- Closed loops
- Proprioceptive feedback
- Reflexes – tool for probing loop function
- Controlled variables – motor vs sensory

**What proprioceptors encode?**

## Proprioceptive receptor types

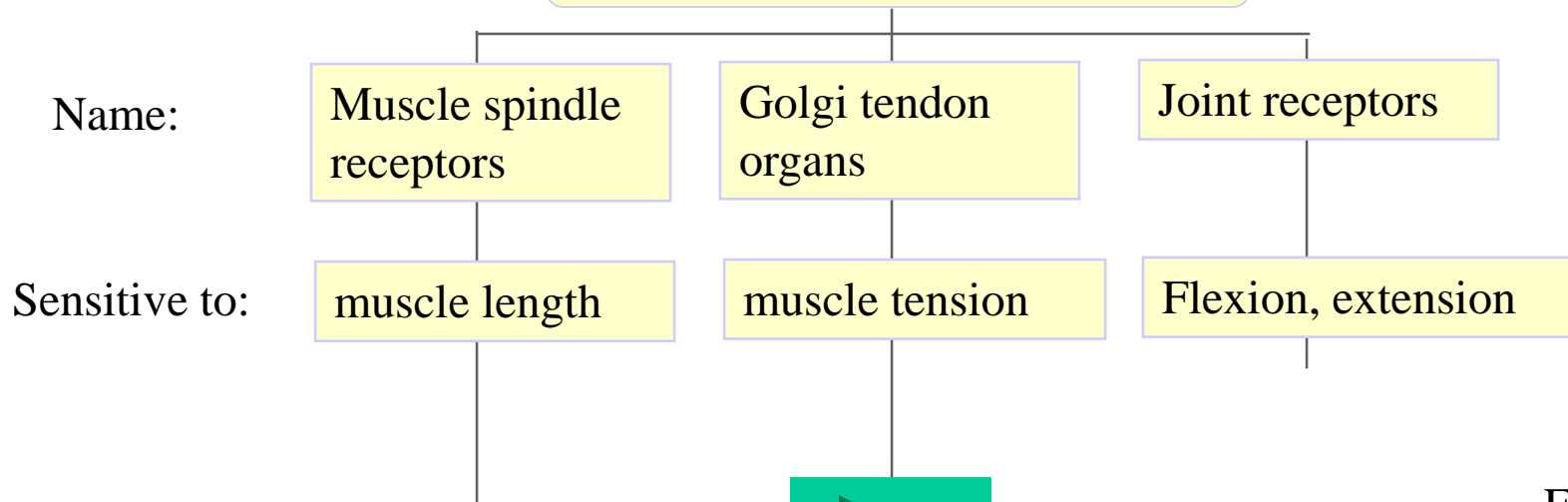

From  
Arthur Prochazka,  
University of Alberta

## Proprioceptive receptor types

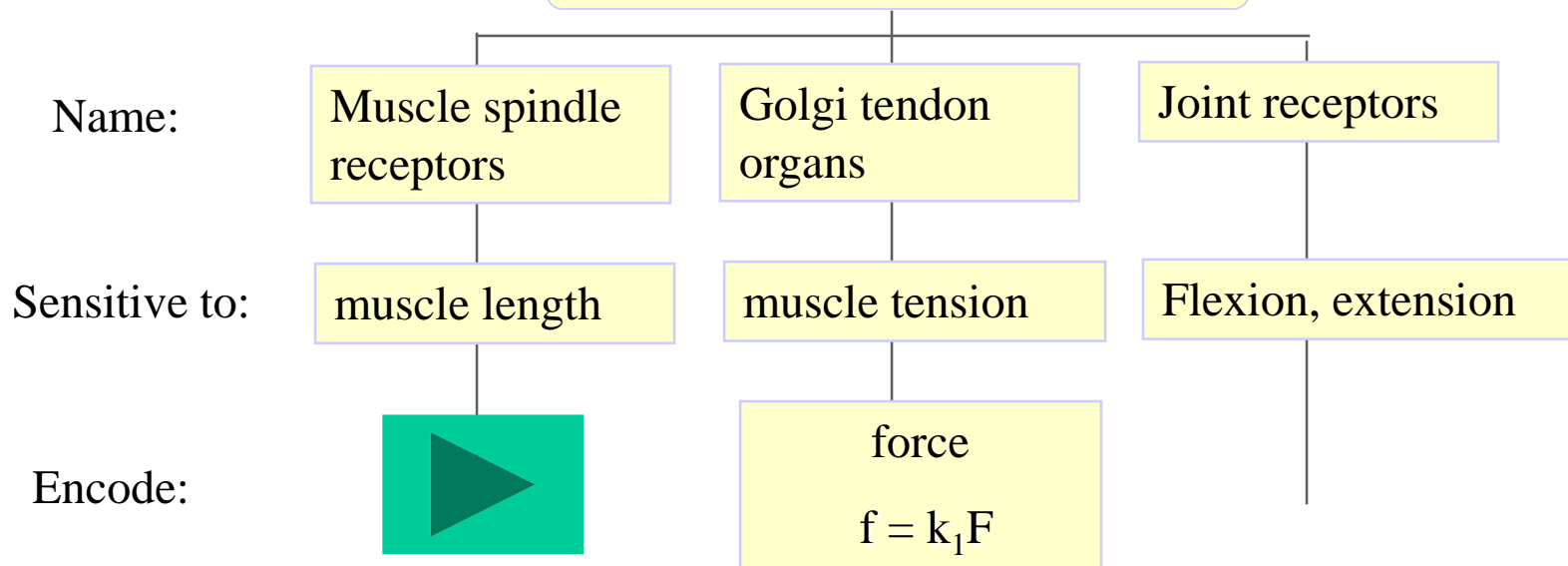

## Proprioceptive receptor types

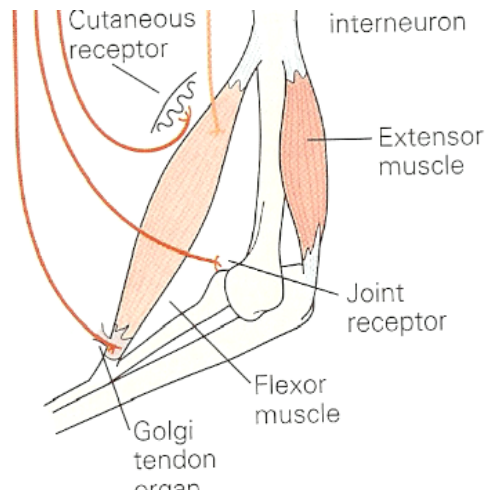
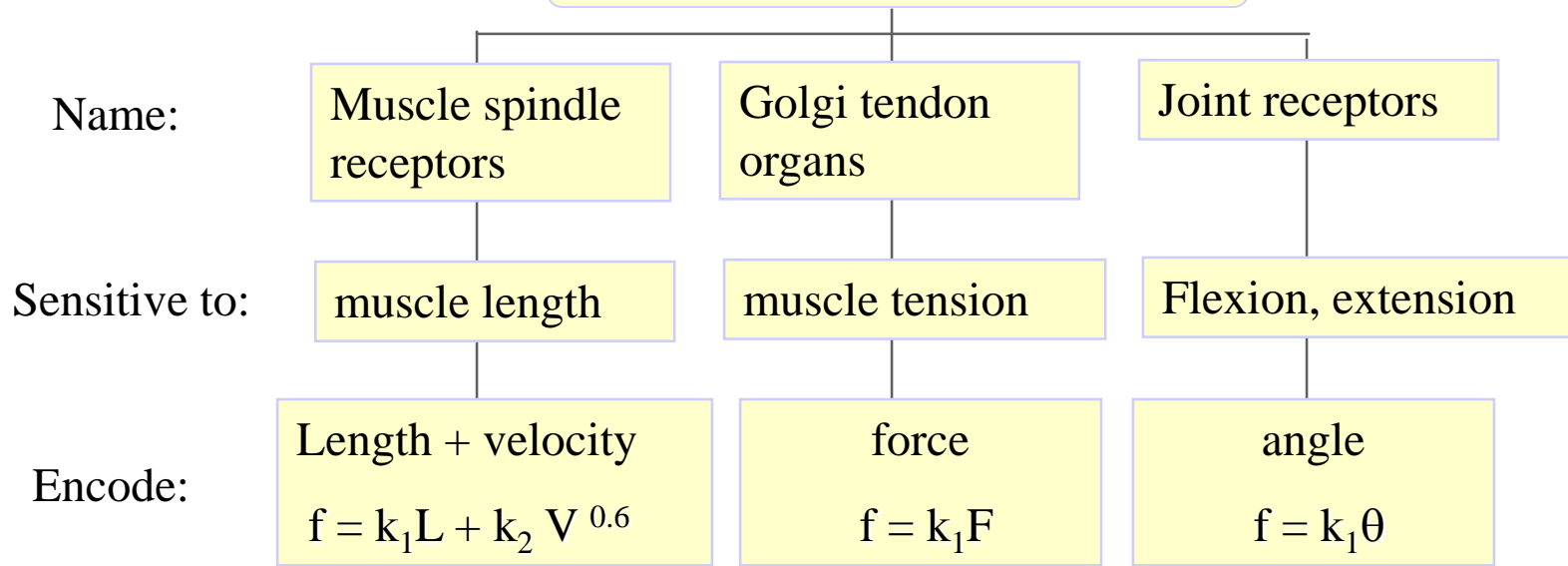

## Proprioceptive receptor types

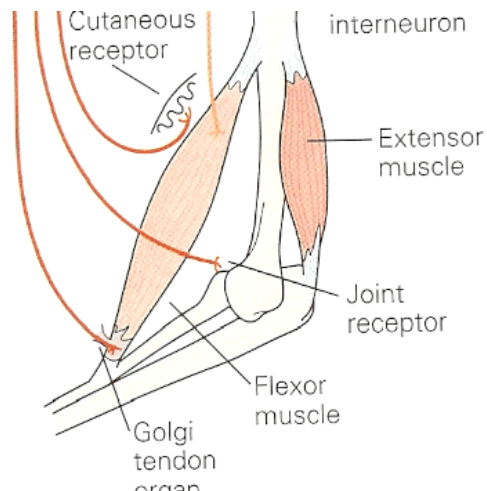
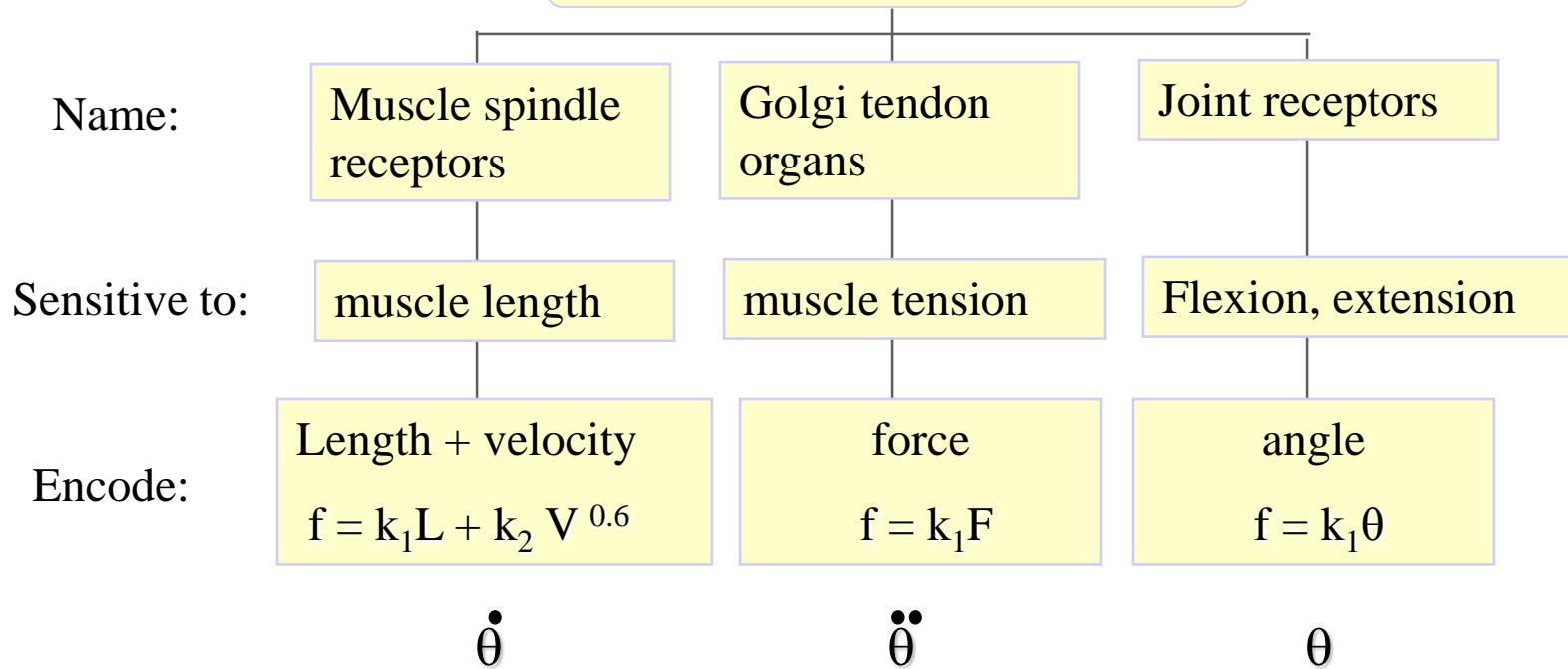

# PID control

- Proportional (to the controlled variable)
- Integral (of the controlled variable)
- Derivative (of the controlled variable)

Present  $\dot{\theta}$

Past  $\theta$

Future  $\ddot{\theta}$

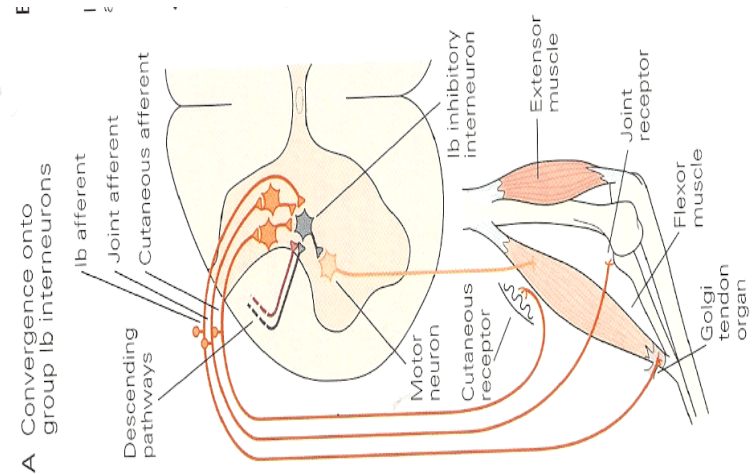
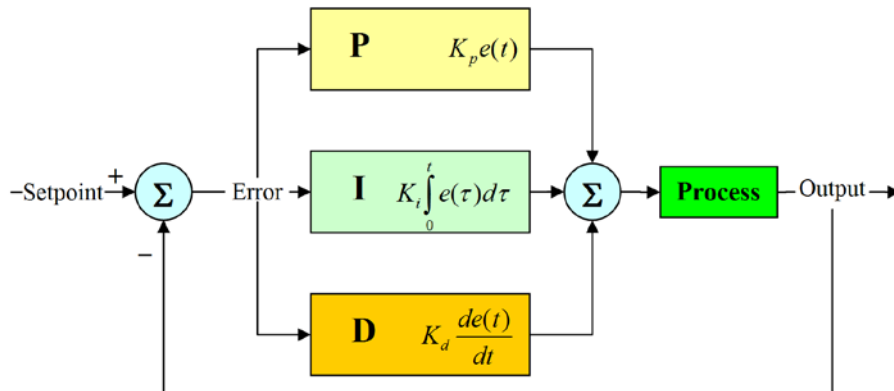

# Negative feedback loop

- **Characteristic:** The effect of a perturbation is in the opposite direction
- **Requirement:** The cumulative sign along the loop is negative
- **Function:** Can keep stable fixed points

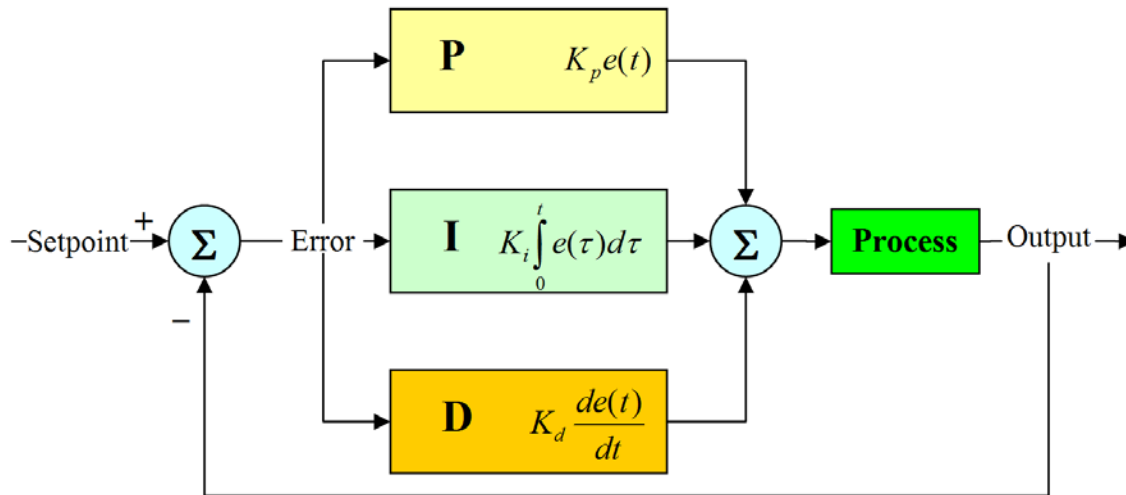

# Positive feedback loop

- **Characteristic:** The effect of a perturbation is in the same direction
- **Requirement:** The cumulative sign along the loop is positive
- **Function:** amplifies perturbations

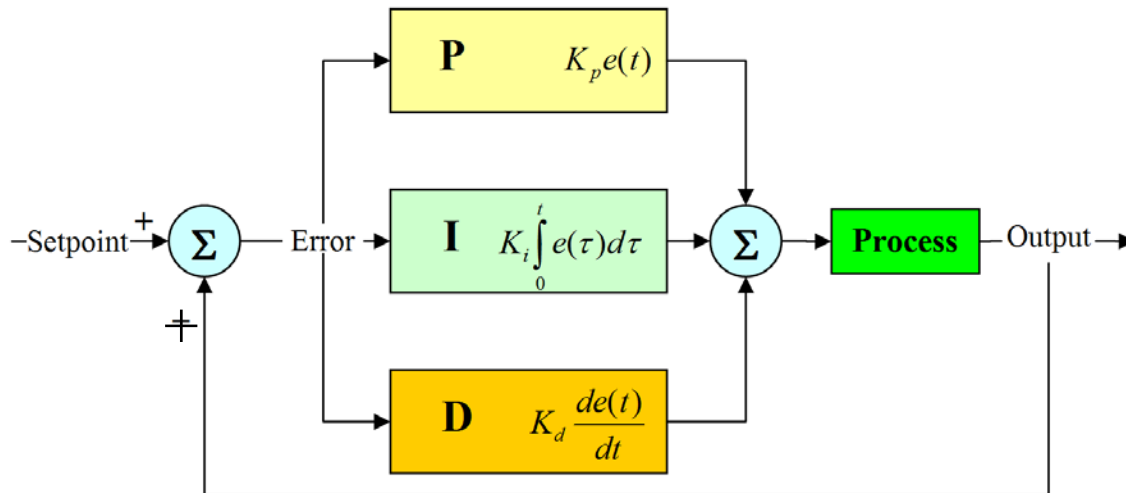

# Motor control

- Closed loops
- Proprioceptive feedback
- Reflexes – tool for probing loop function
- Controlled variables – motor vs sensory

# The stretch reflex probes the control function of muscle spindles

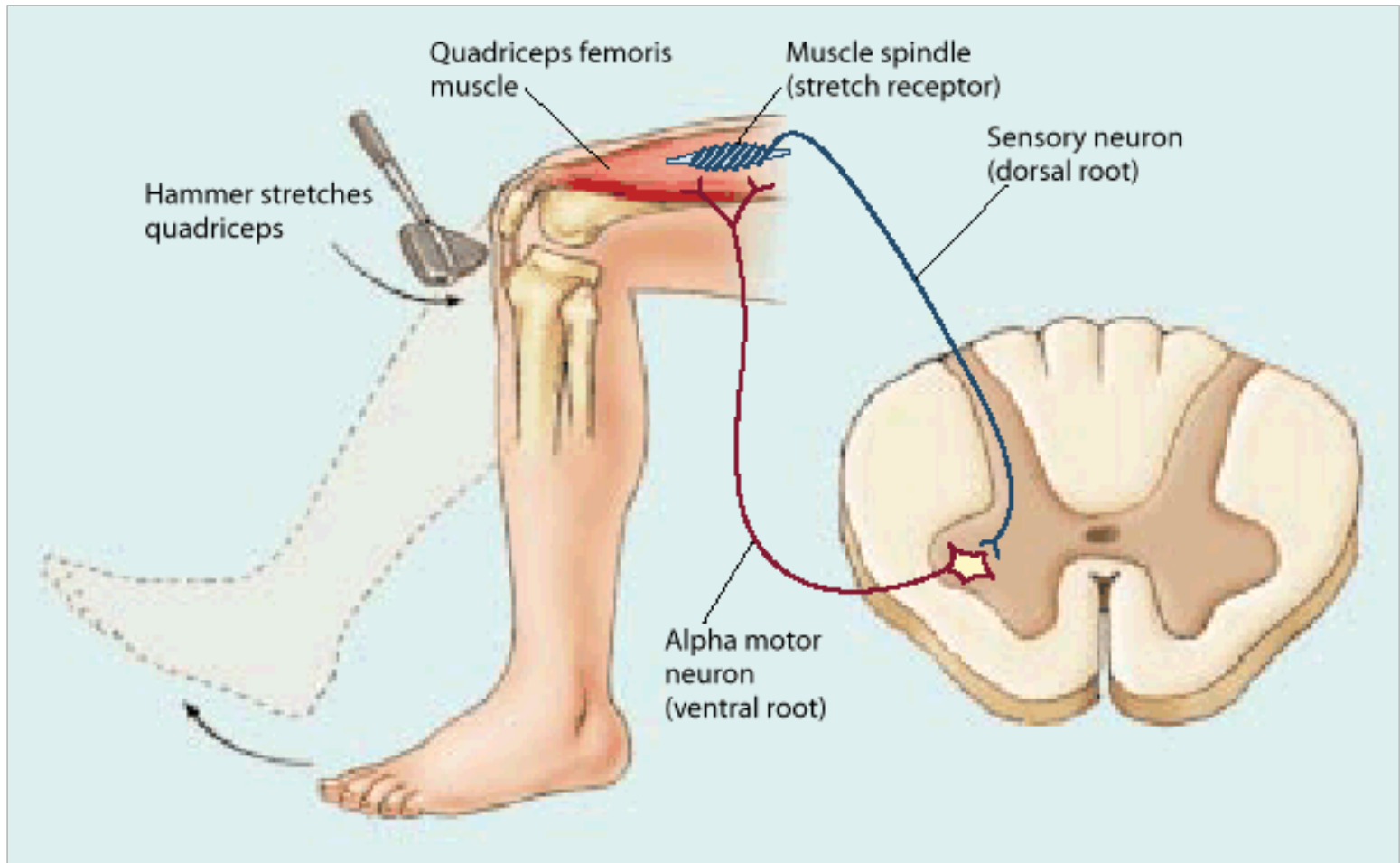

# Is the loop positive or negative?

- ◆ The stroke **stretches** the muscle
  - ◆ As a result the muscle **contracts**
  - ◆ The result opposes the perturbation
- => negative FB loop

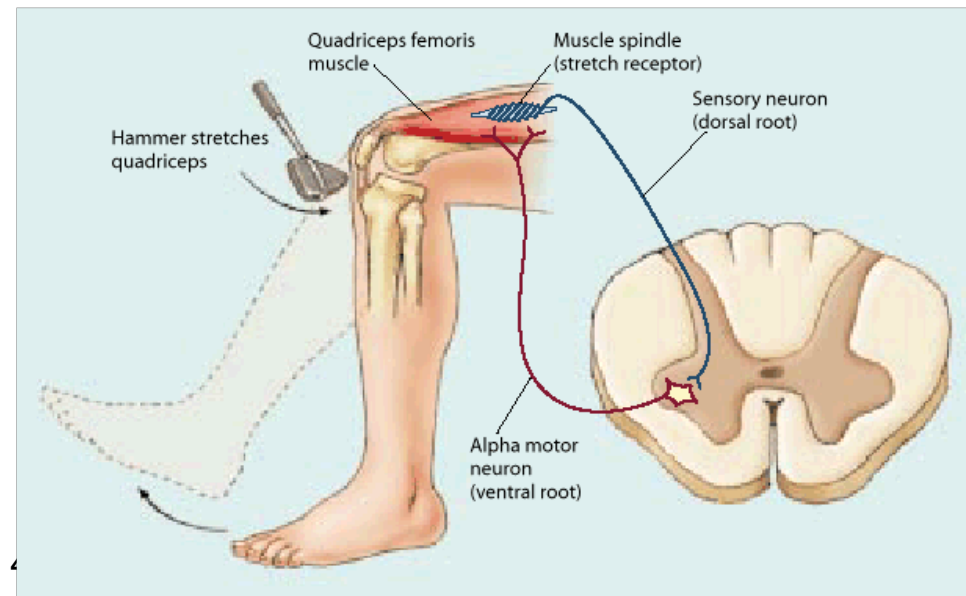

# the anatomical loop

- ◆ Muscle spindle **excites** the motor neuron
- ◆ Motor neuron **excites** muscle fibers
- ◆ Muscle contraction **suppresses** spindle response

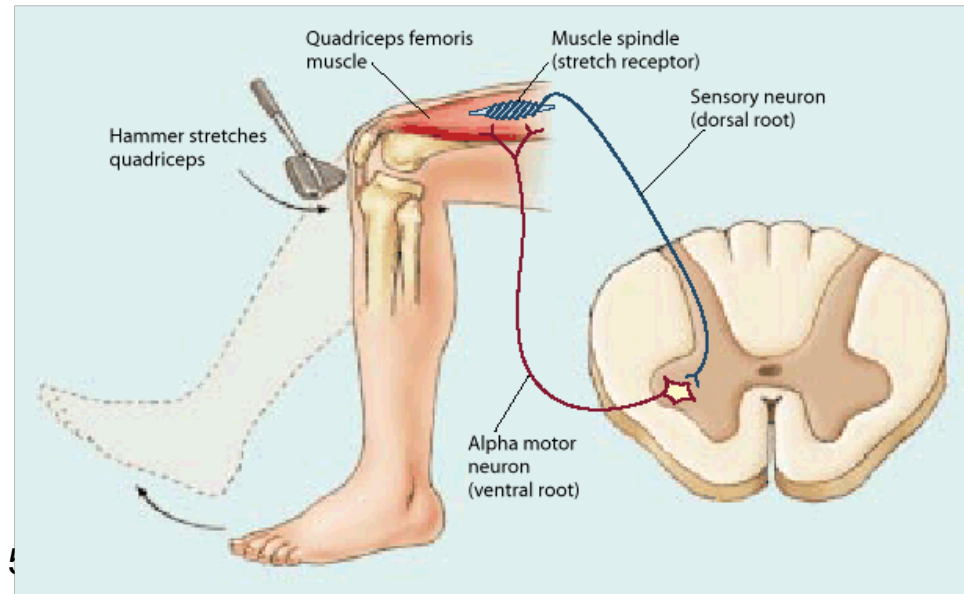
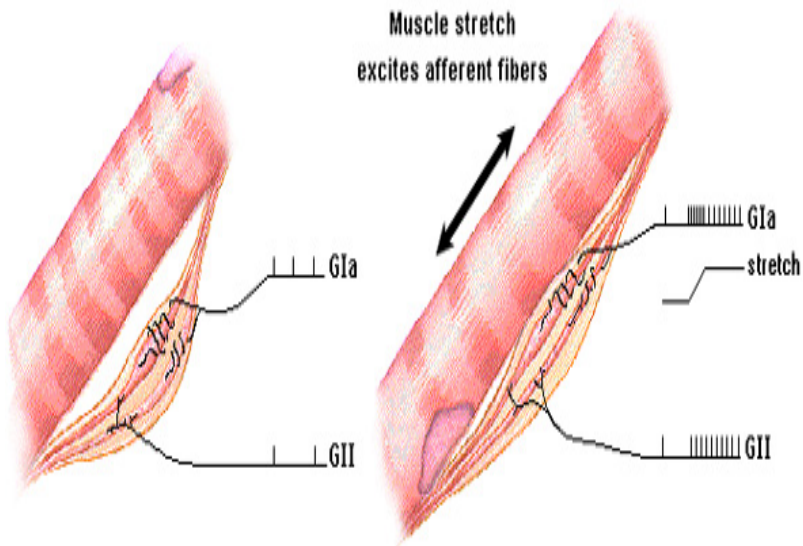

## Proprioceptive receptor types

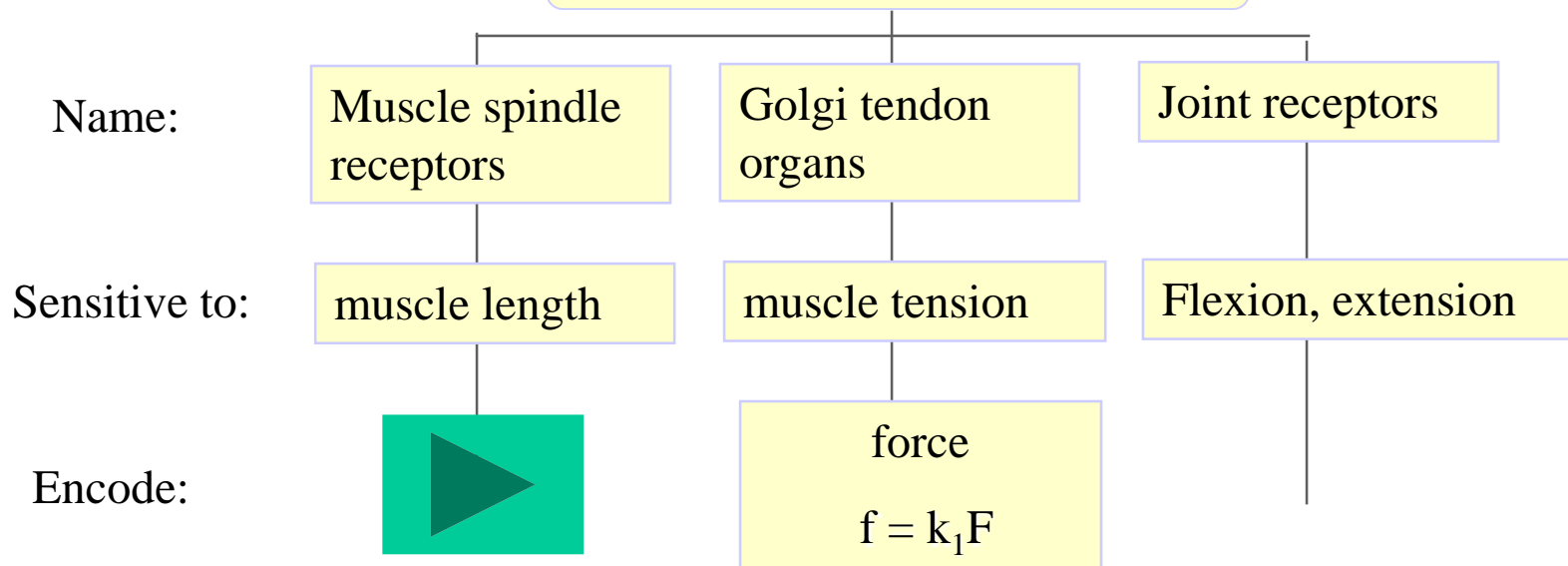

Why proprioceptors fire at rest?

And why aren't we aware of it?

**What about the flexor muscles?**

**Positive or negative loop?**

**What is the underlying circuit?**

**Take it as homework – may appear in the exam**

# Pain reflex

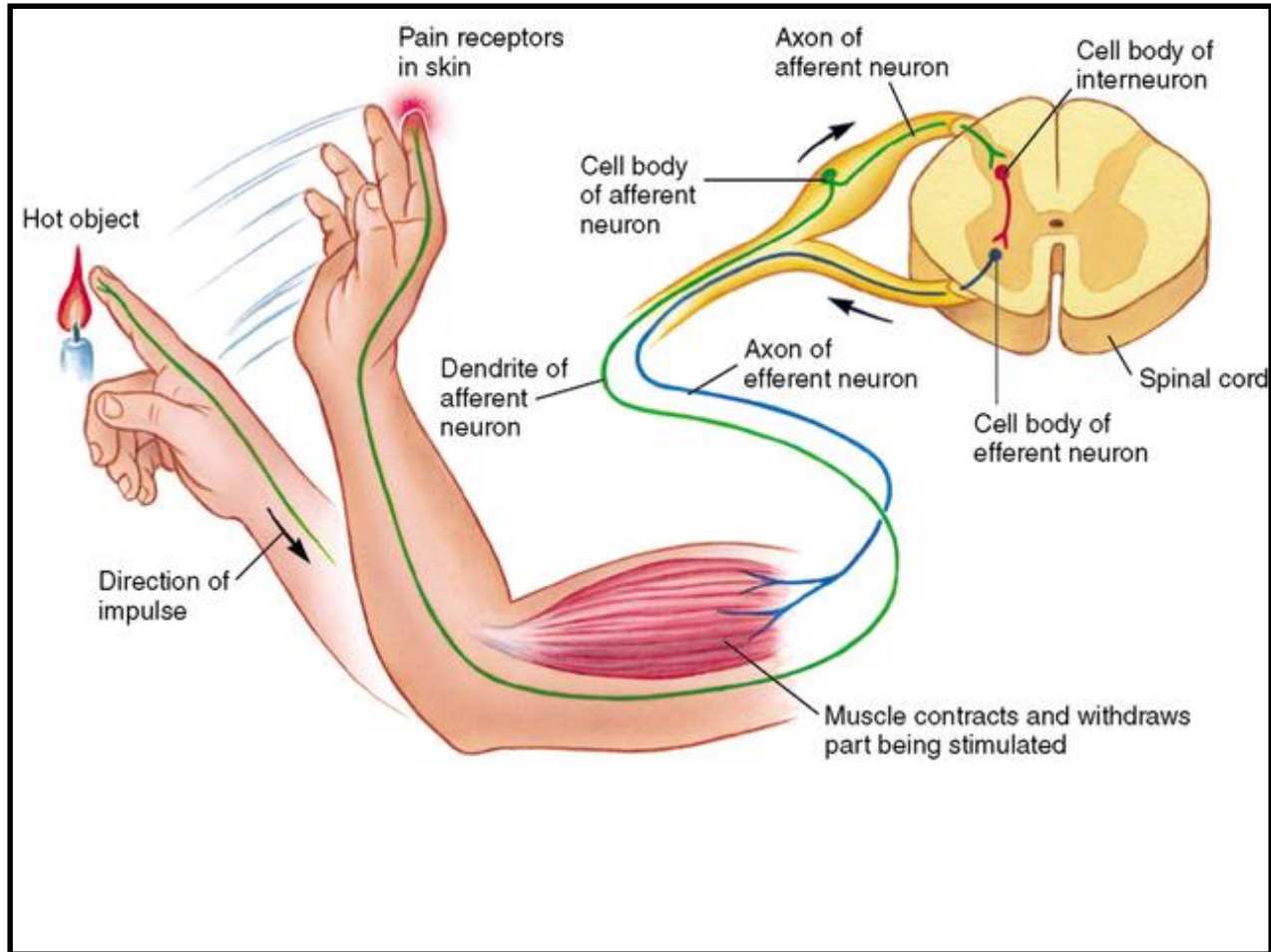

**Positive or negative?**

**What is the underlying circuit?**

**Same...**

# Motor control

- Closed loops
- Proprioceptive feedback
- Reflexes – tool for probing loop function
- Controlled variables – motor vs sensory

- Break ?

# Sensory-motor loops of the vibrissal system

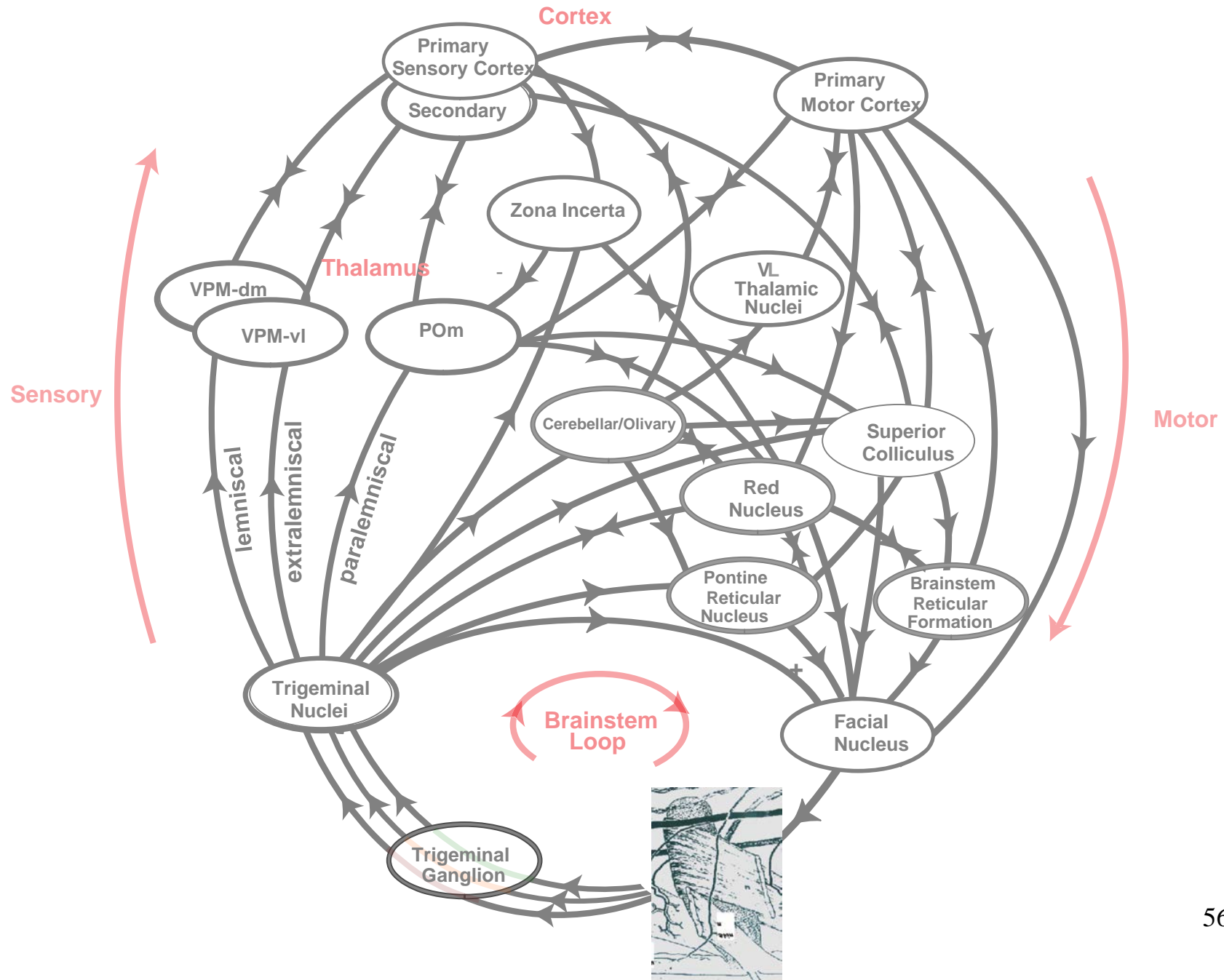

# Basic principles of closed-loop control

# Set point

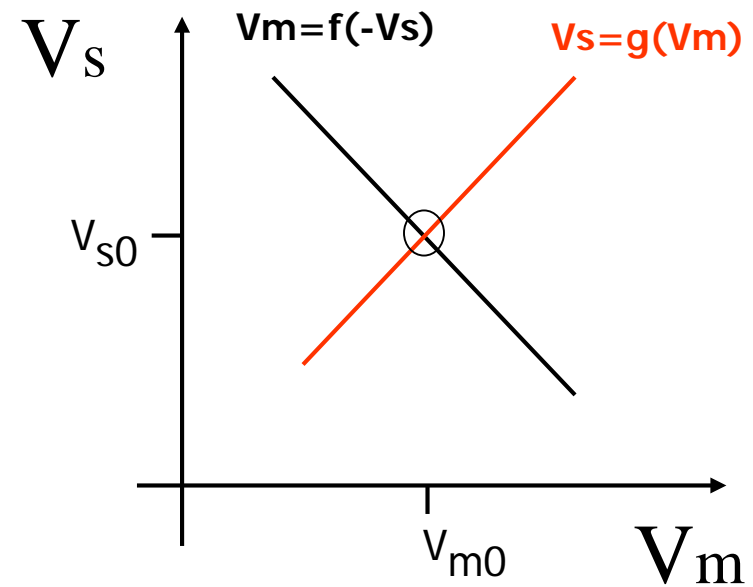
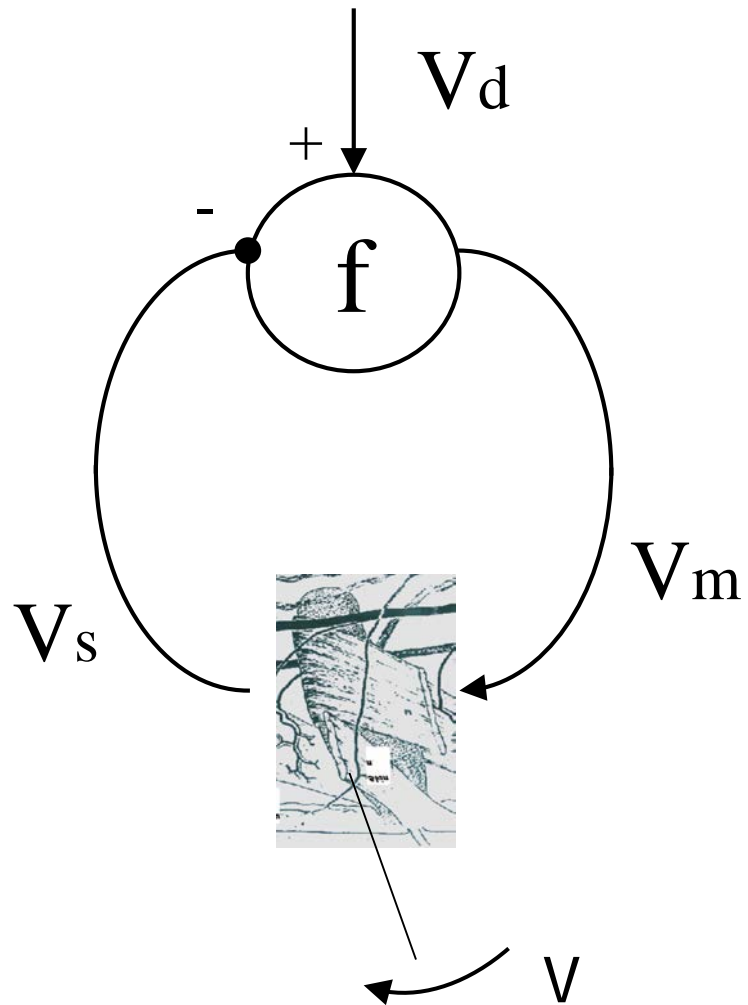

# Set point

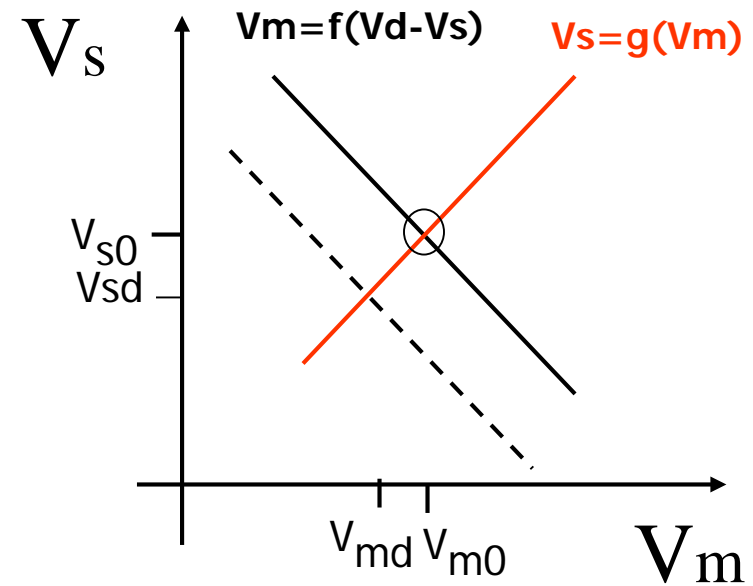
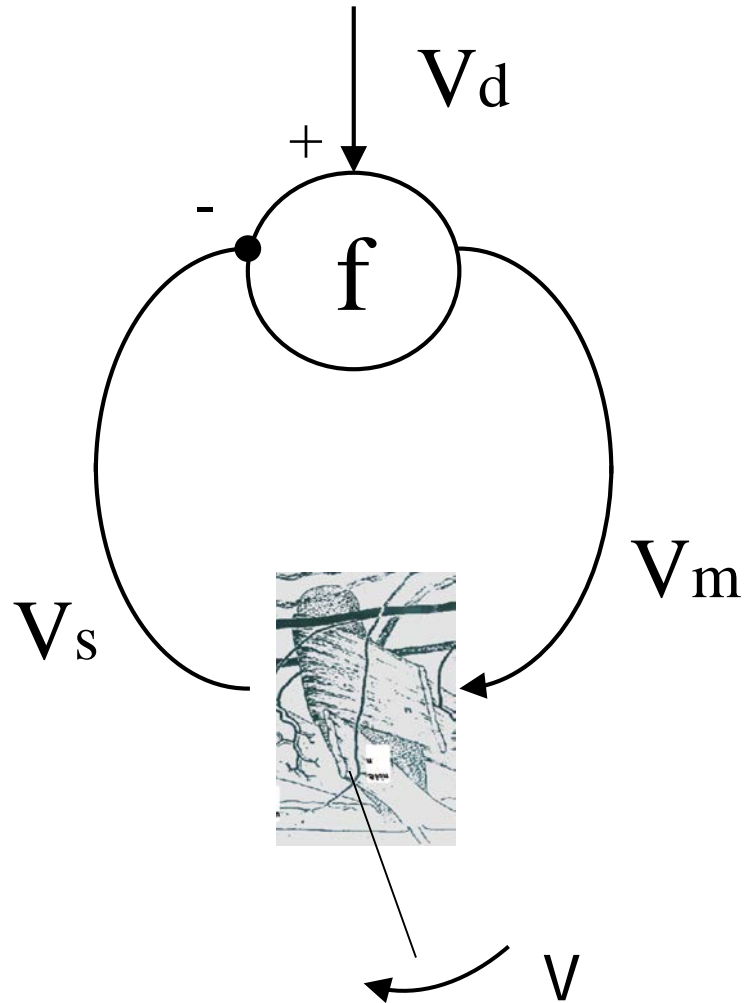

# Direct control without direct connection

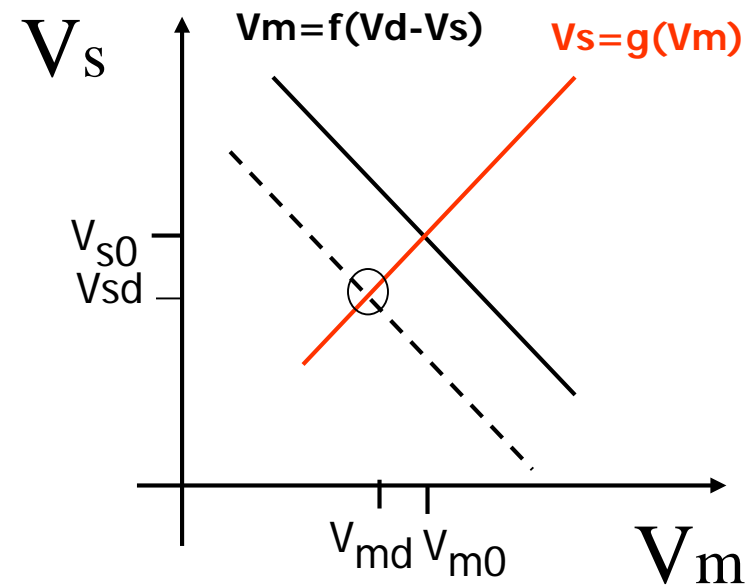
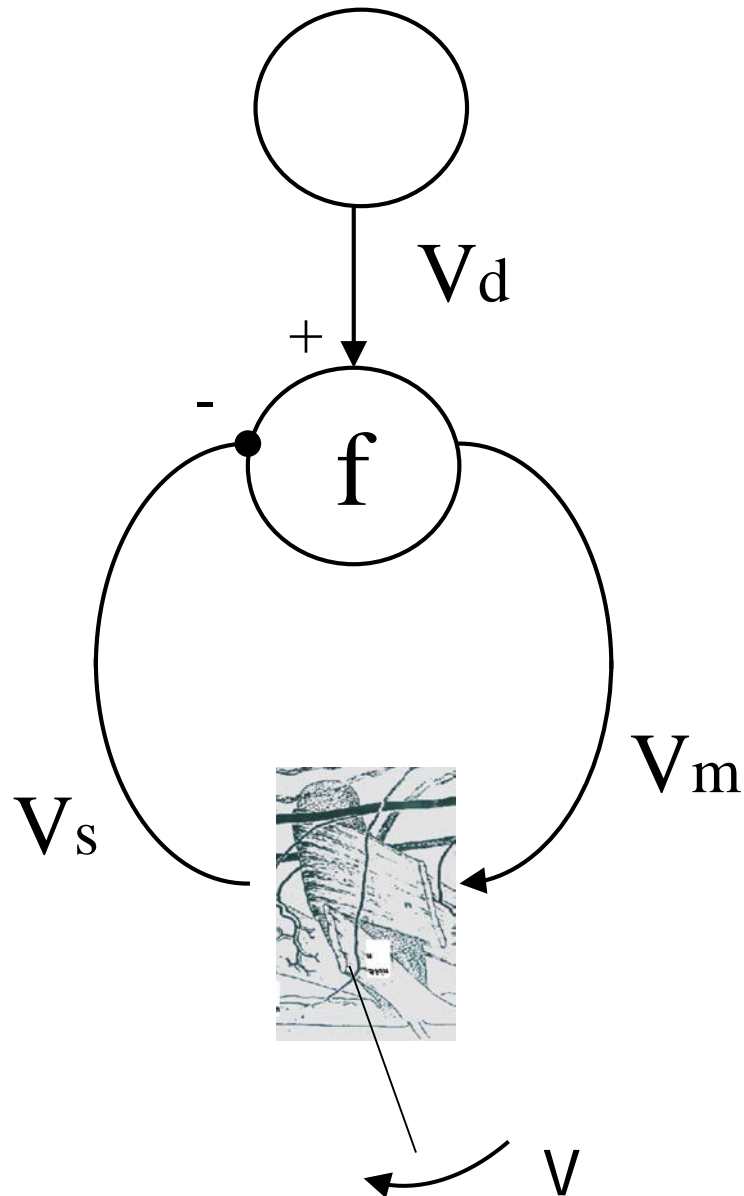

# Nested loops

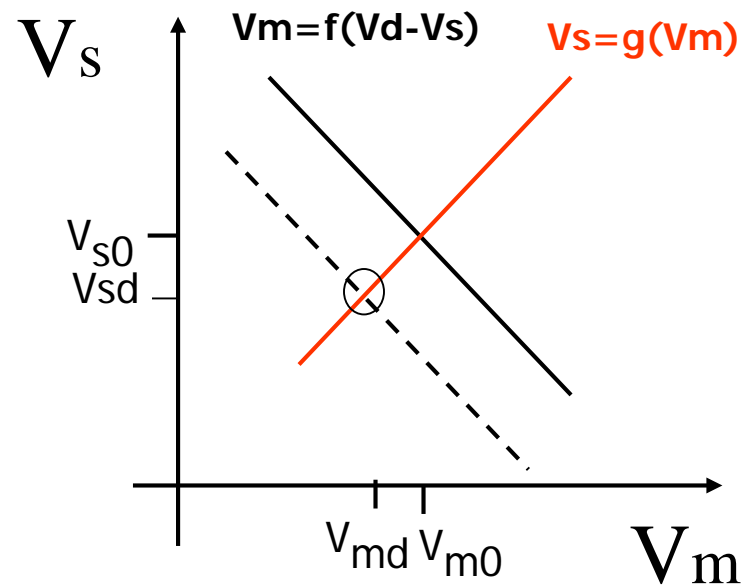
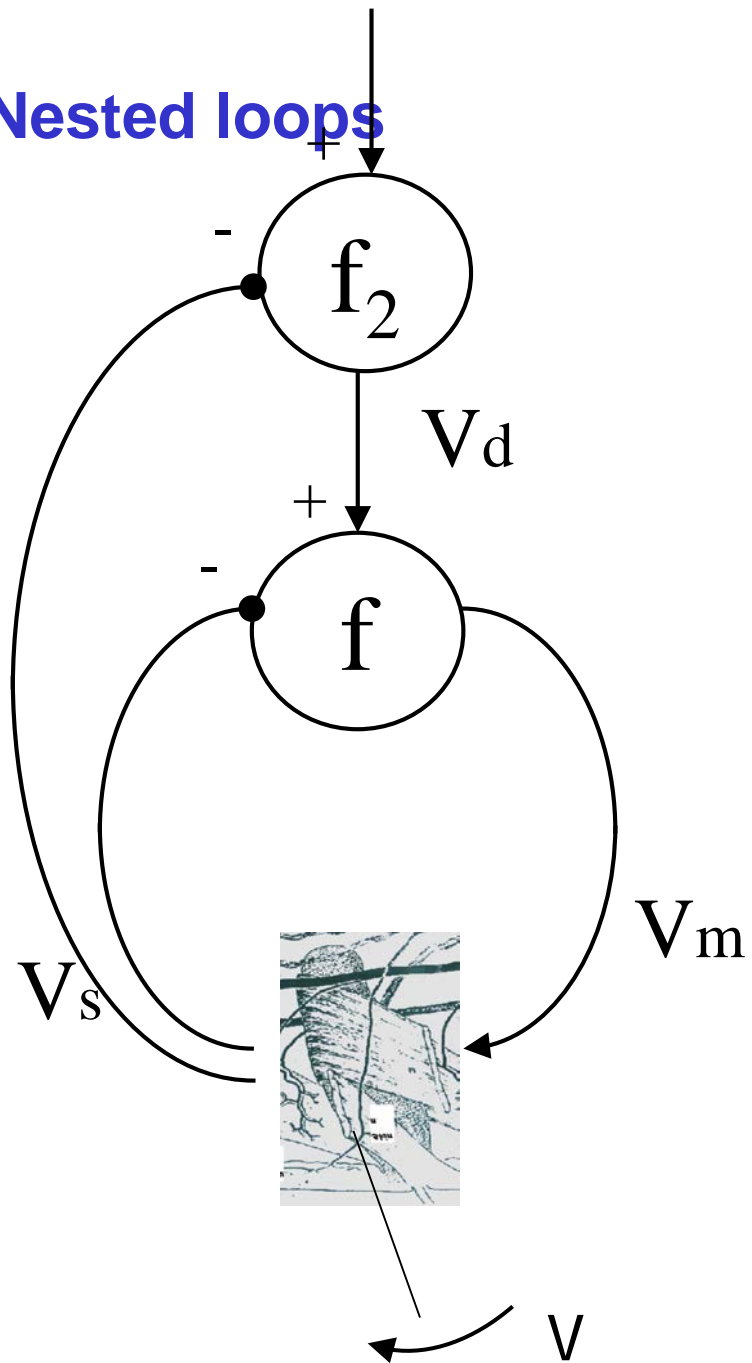

# Parallel loops

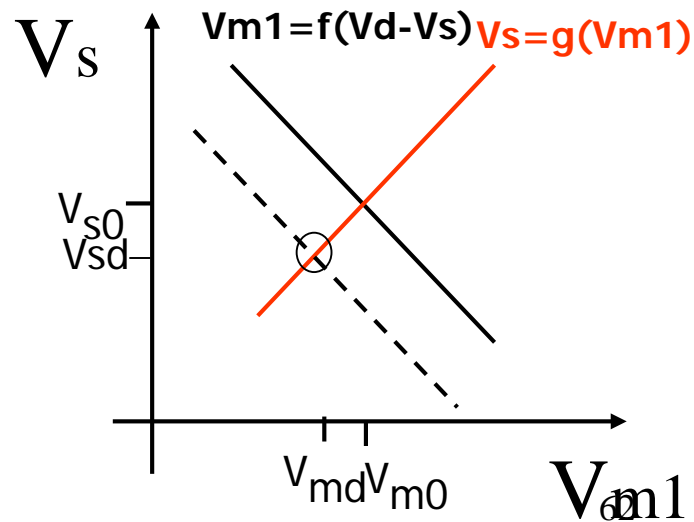
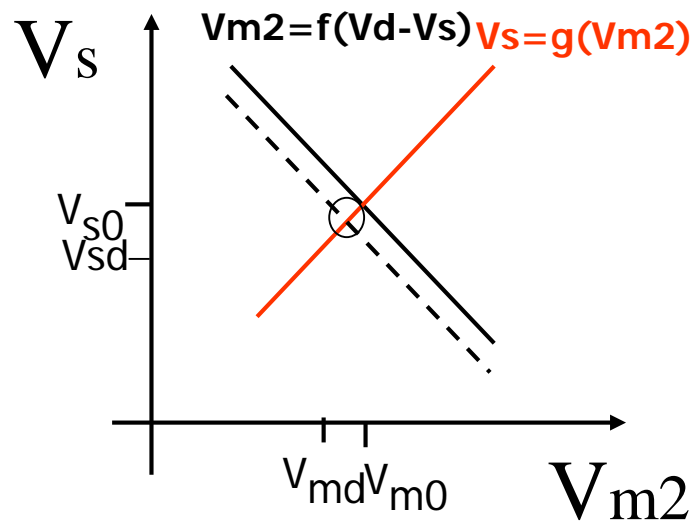
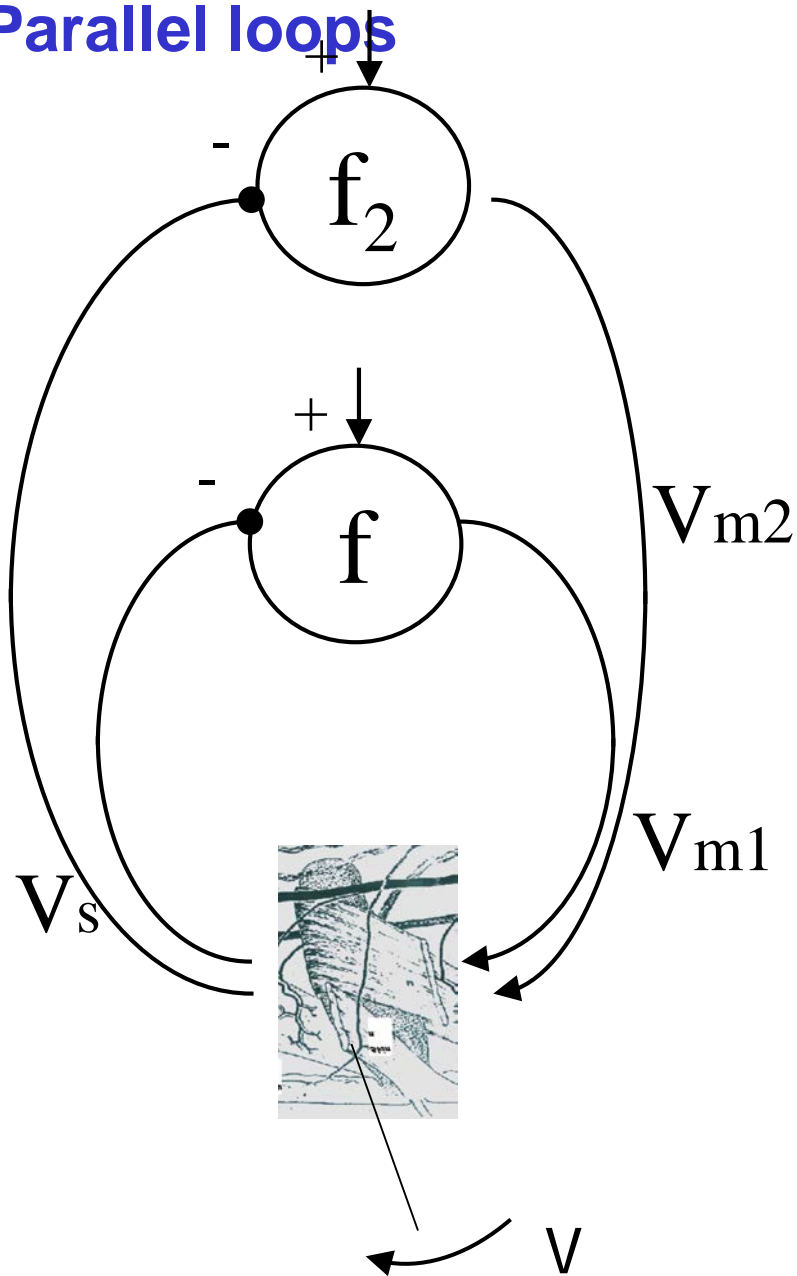

# Parallel loops

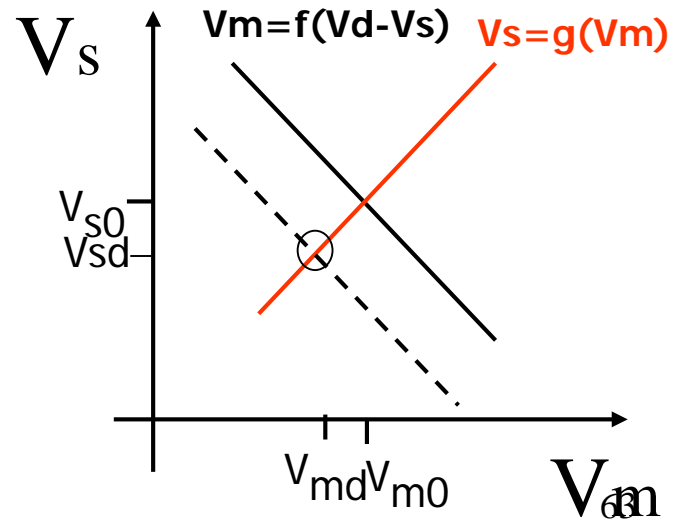
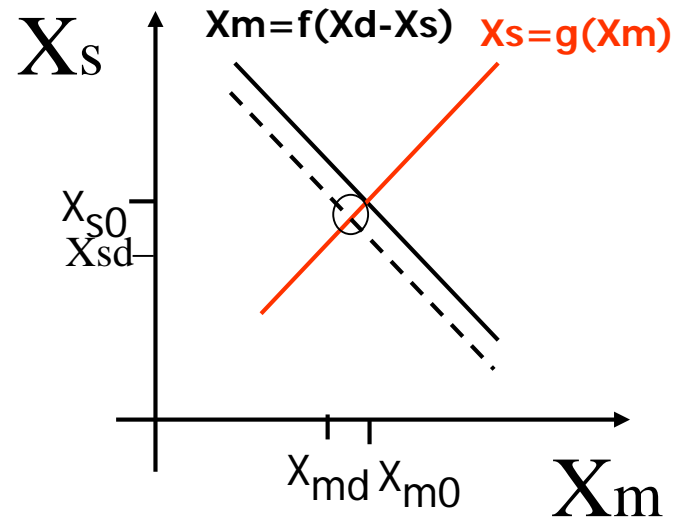
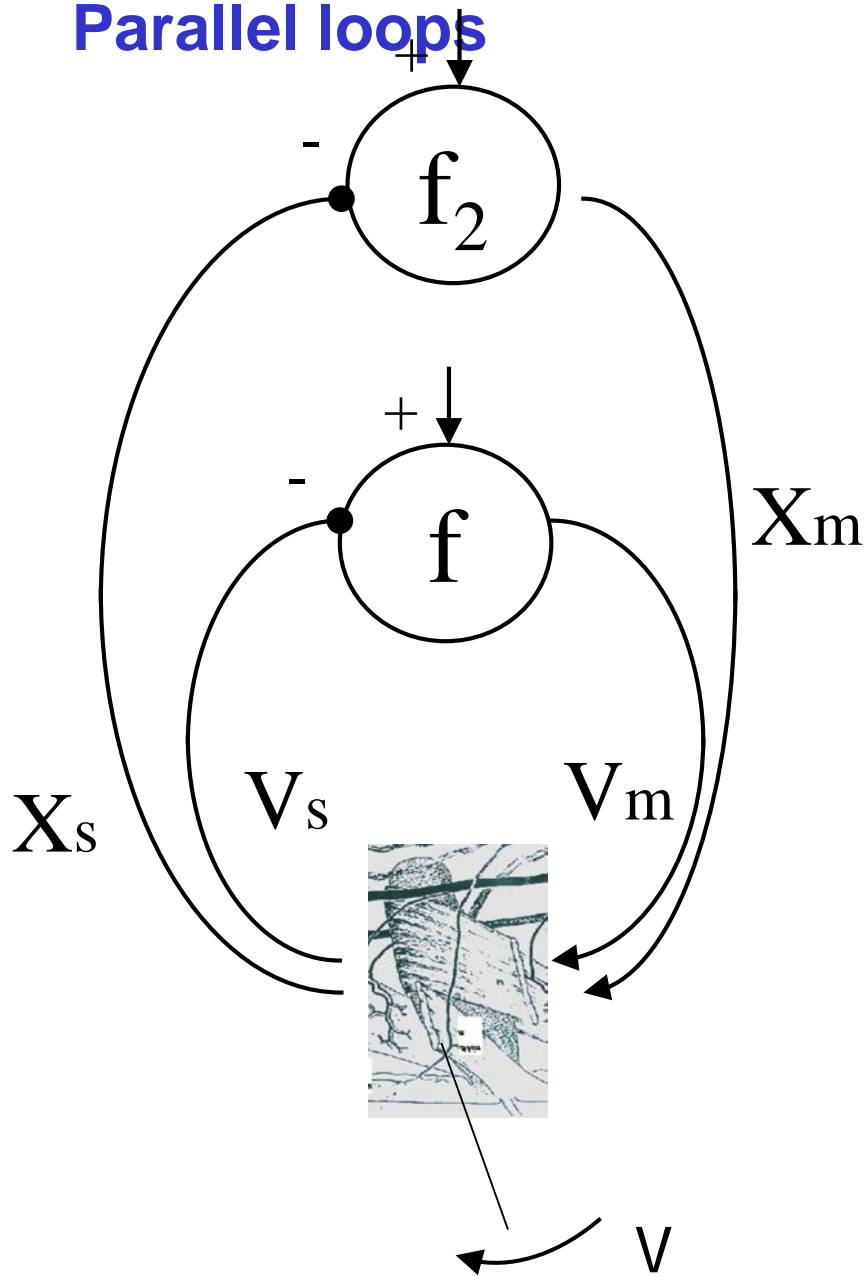

# Closed loops in active sensing

The controlled variables can be

- Motor ( $X_m$ )  
(velocity, amplitude, duration, direction, ...)
- Sensory ( $X_s$ )  
(Intensity, phase, ...)
- Object (via  $X_m - X_s$  relationships)  
(location, SF, identity, ...)

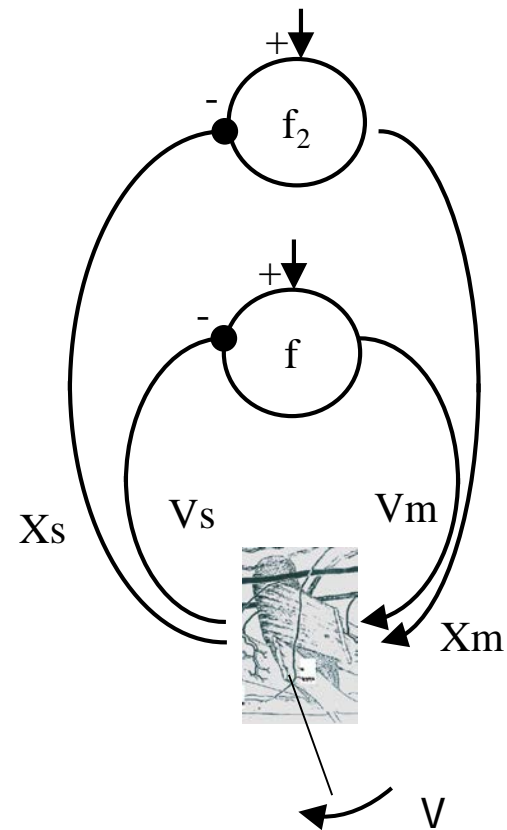

# Sensory-motor loops of the vibrissal system

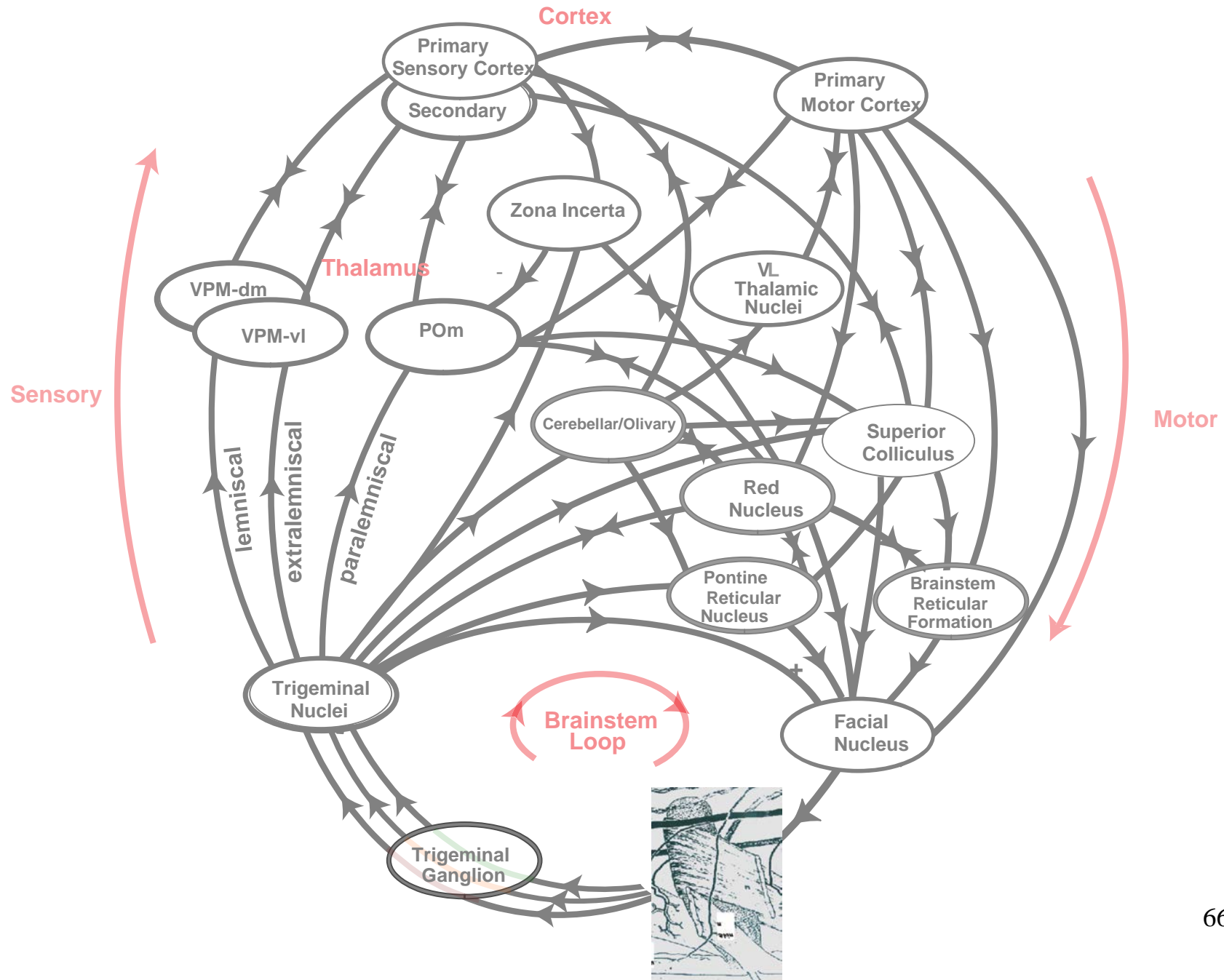

# Sensory-motor loops of the vibrissal system

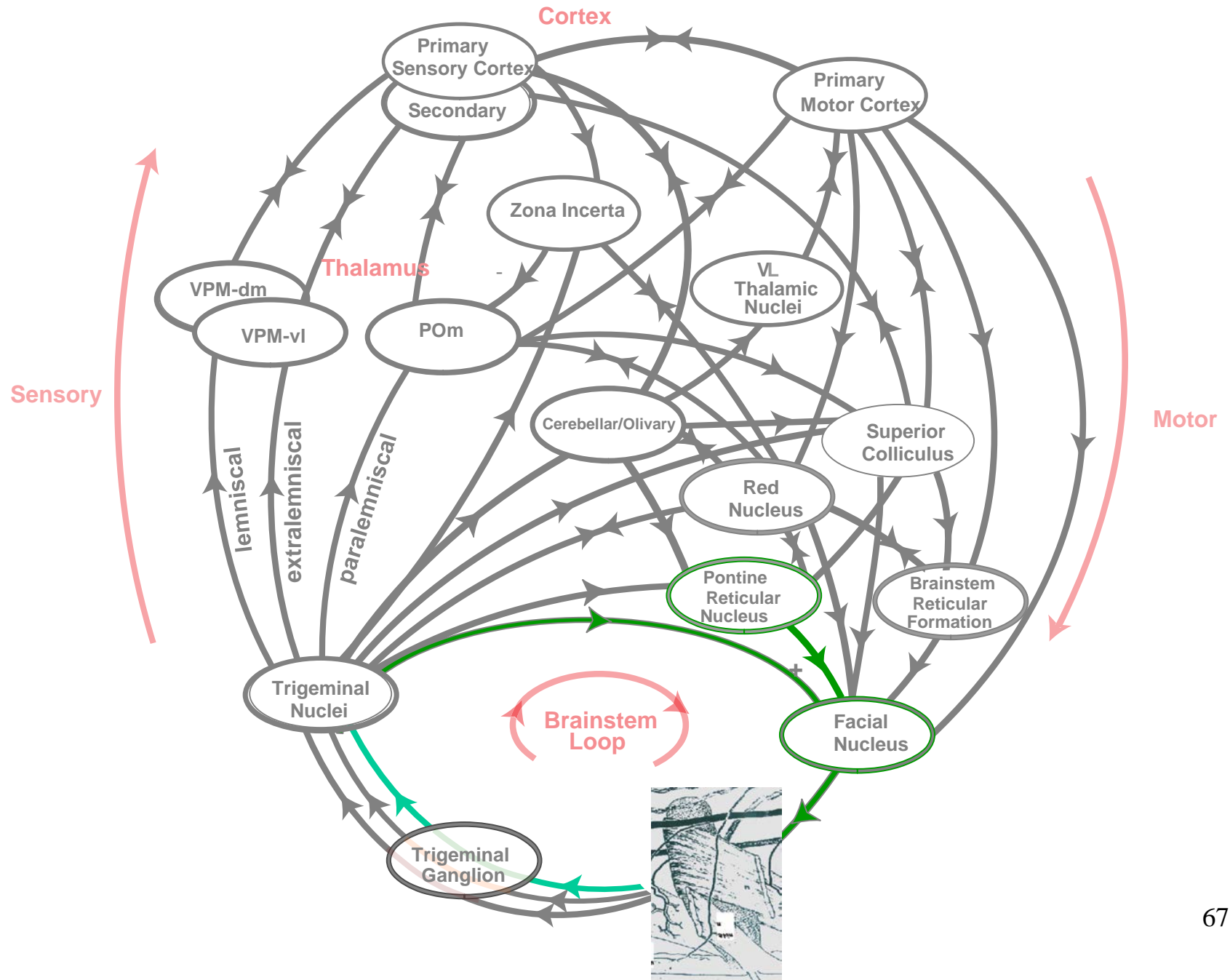

# Sensory-motor loops of the vibrissal system

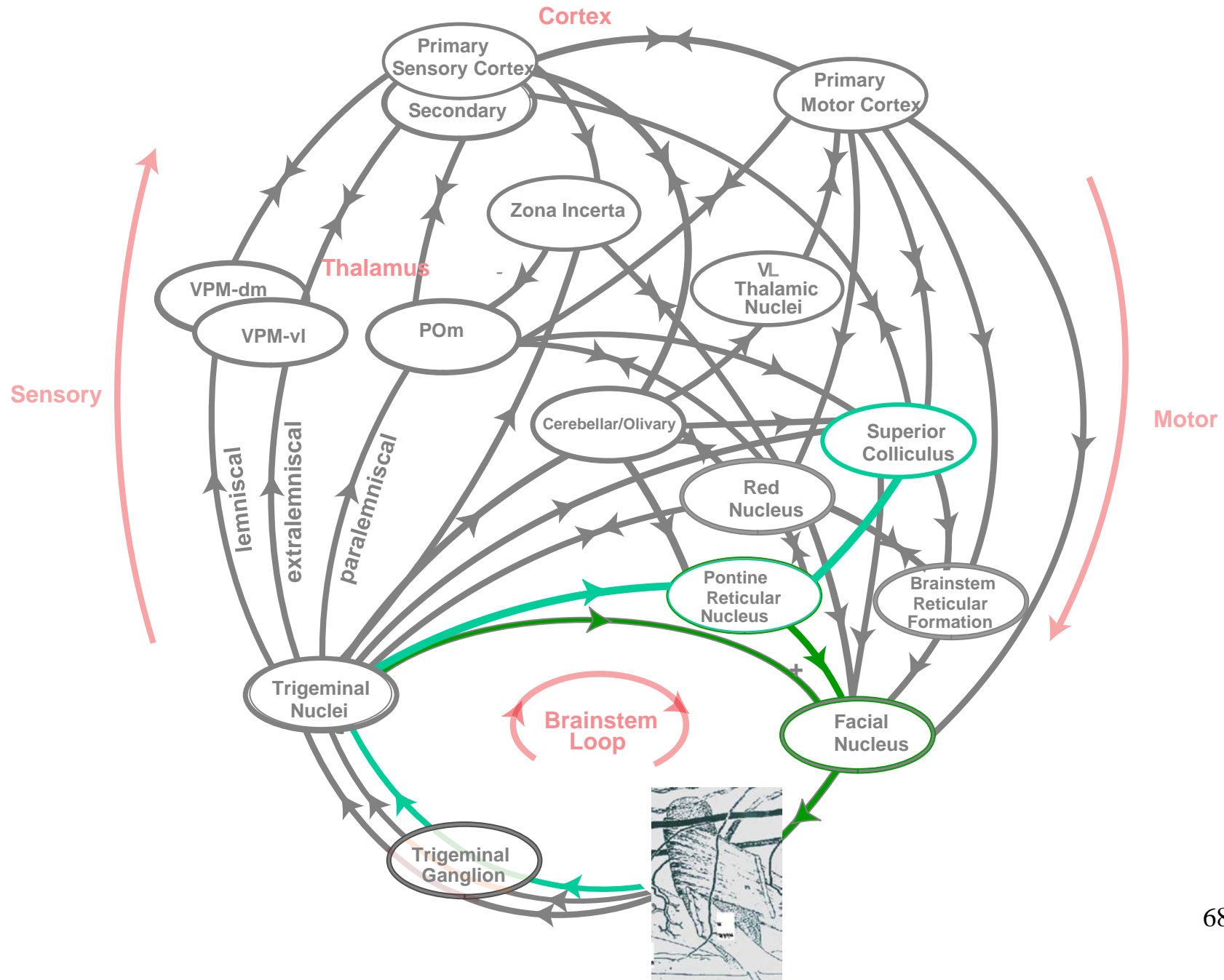

# Sensory-motor loops of the vibrissal system

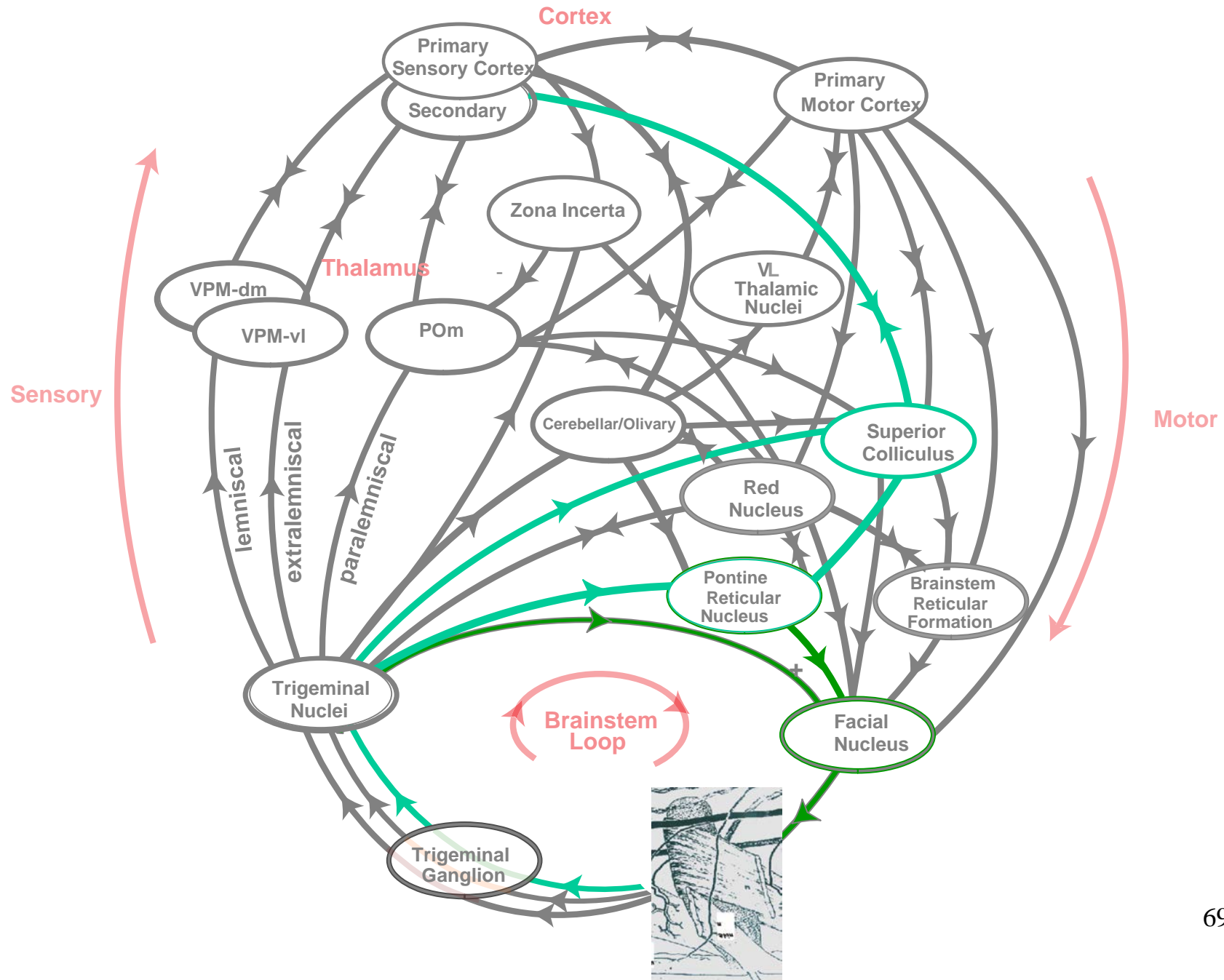

**Active sensing  
in  
the vibrissal system**

# Sensory signal conduction

## The vibrissal system

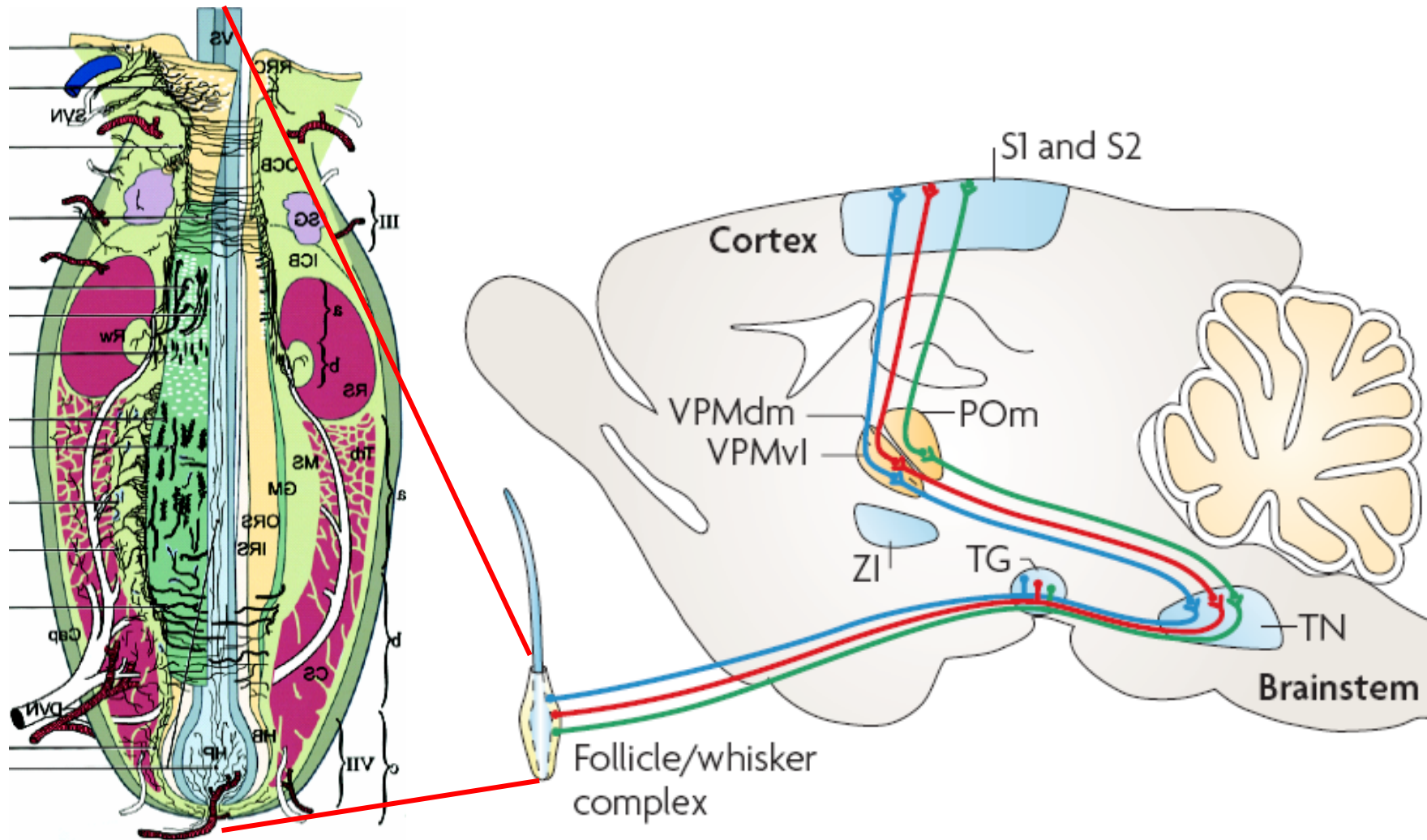

# Sensory signal conduction

## The vibrissal system

whisker

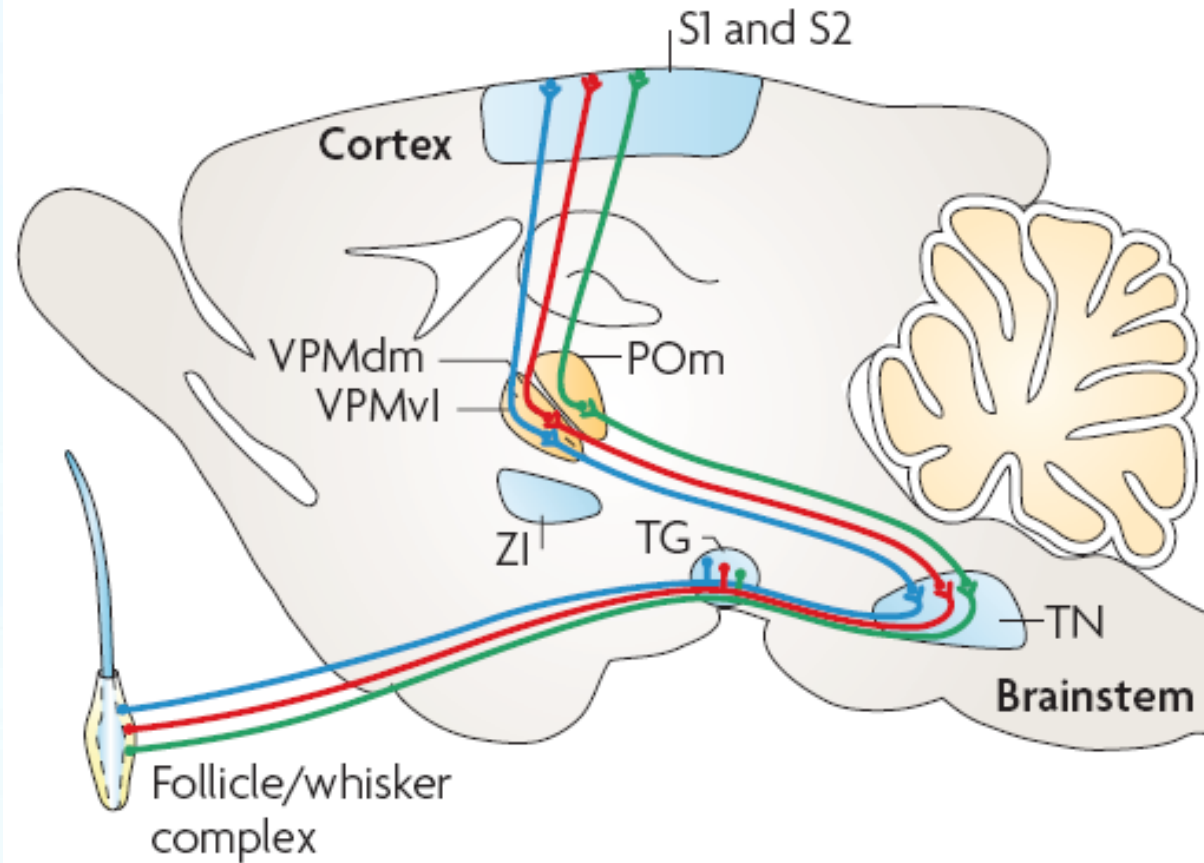
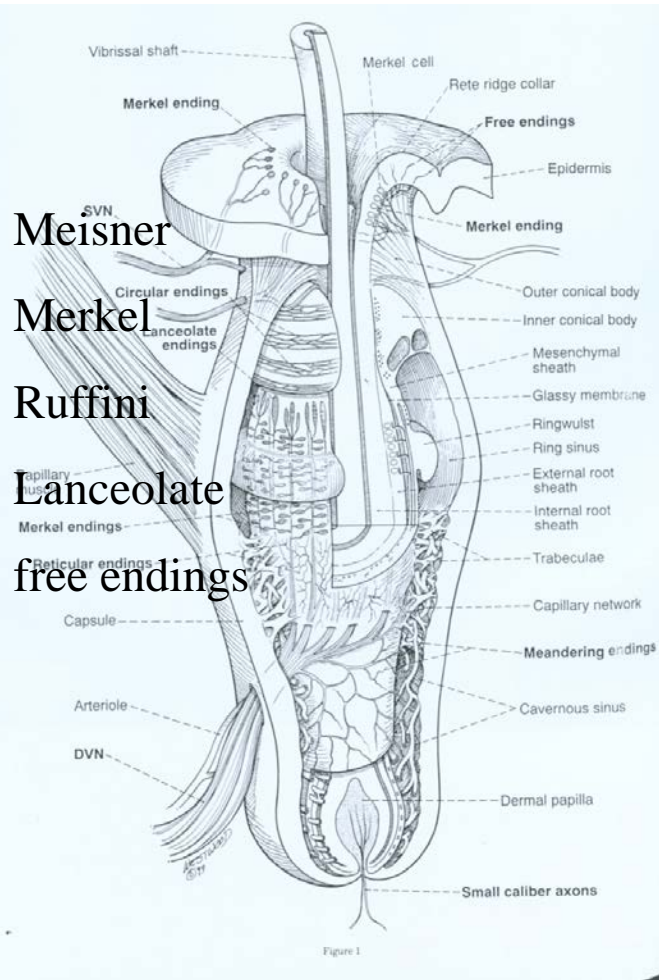

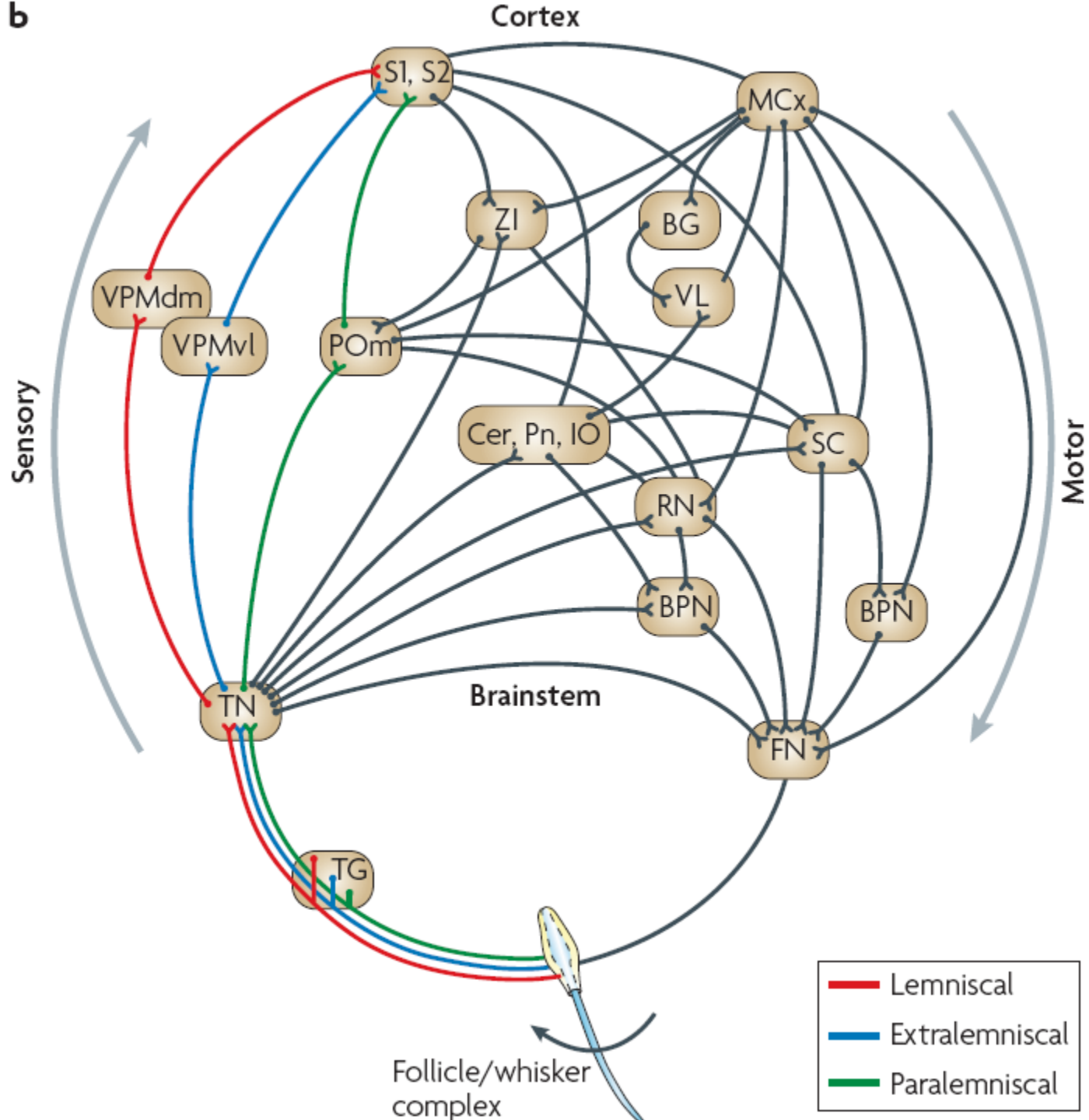
**b**

# Sensory-motor loops of the vibrissal system

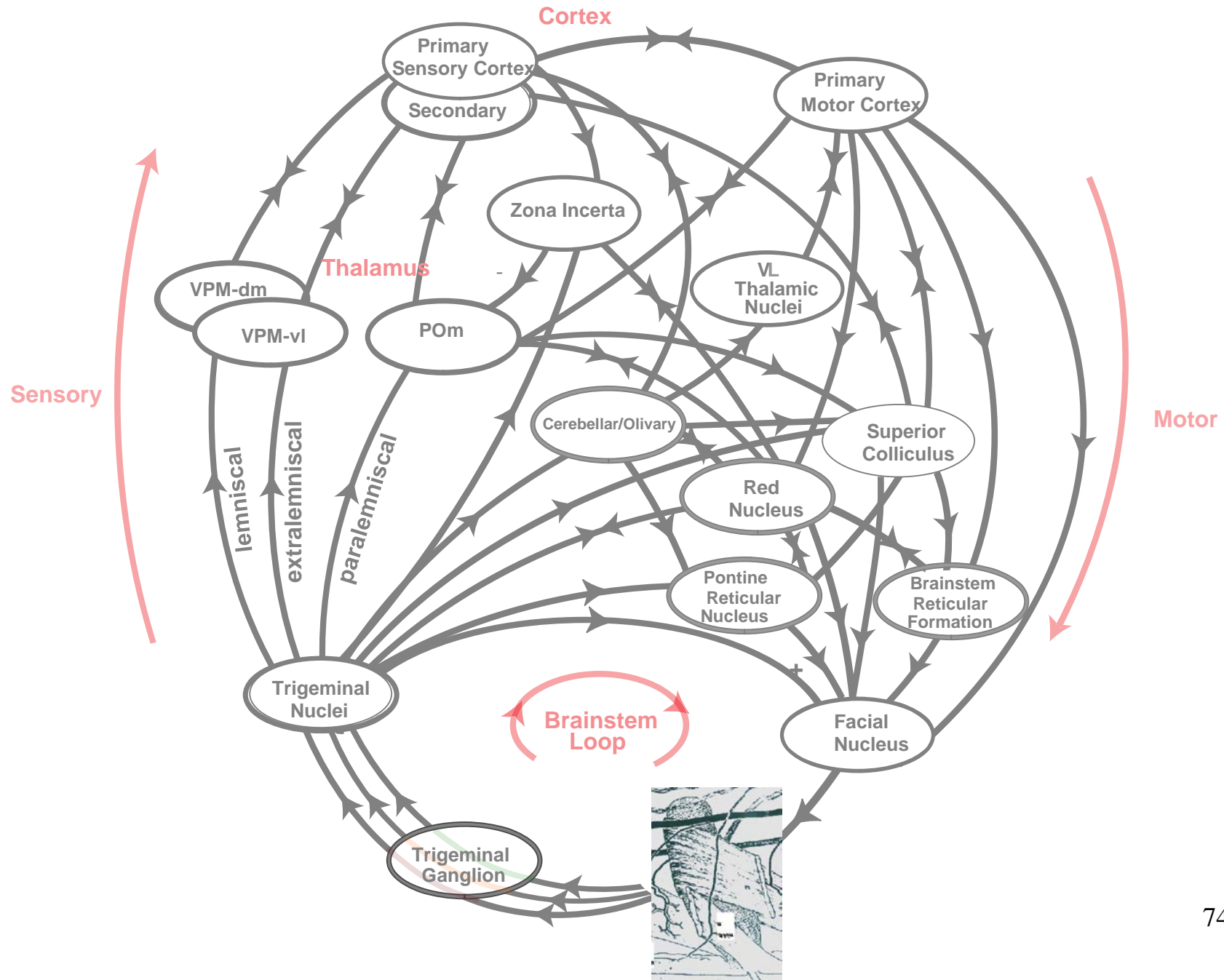

# Motor control of whiskers

## Intrinsic muscles

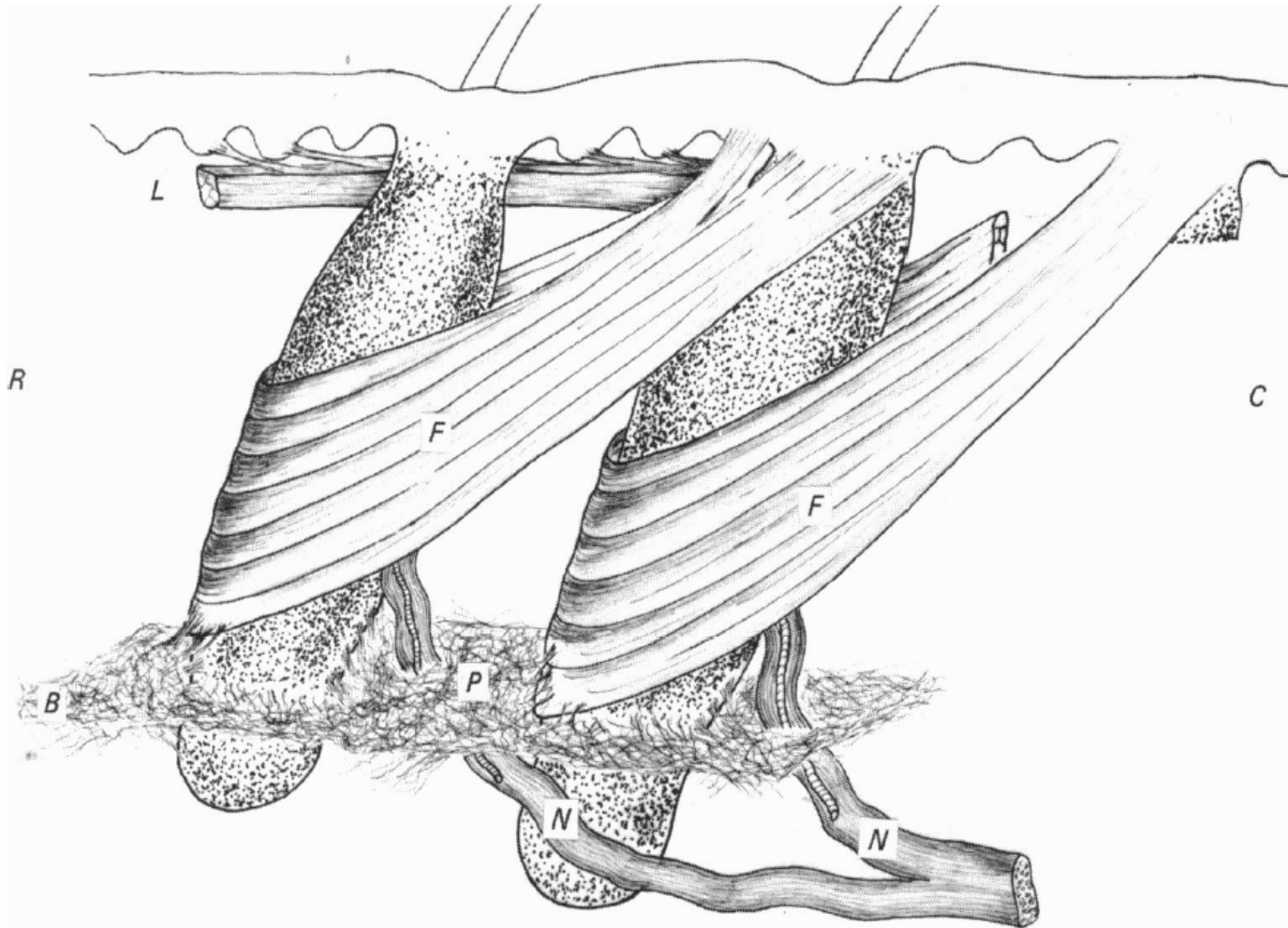

# Follicle as a motor-sensory junction

- Motor signals move the follicle and whisker
- Follicle receptors report back details of self motion = proprioception
- Plus perturbations of this motion caused by the external world

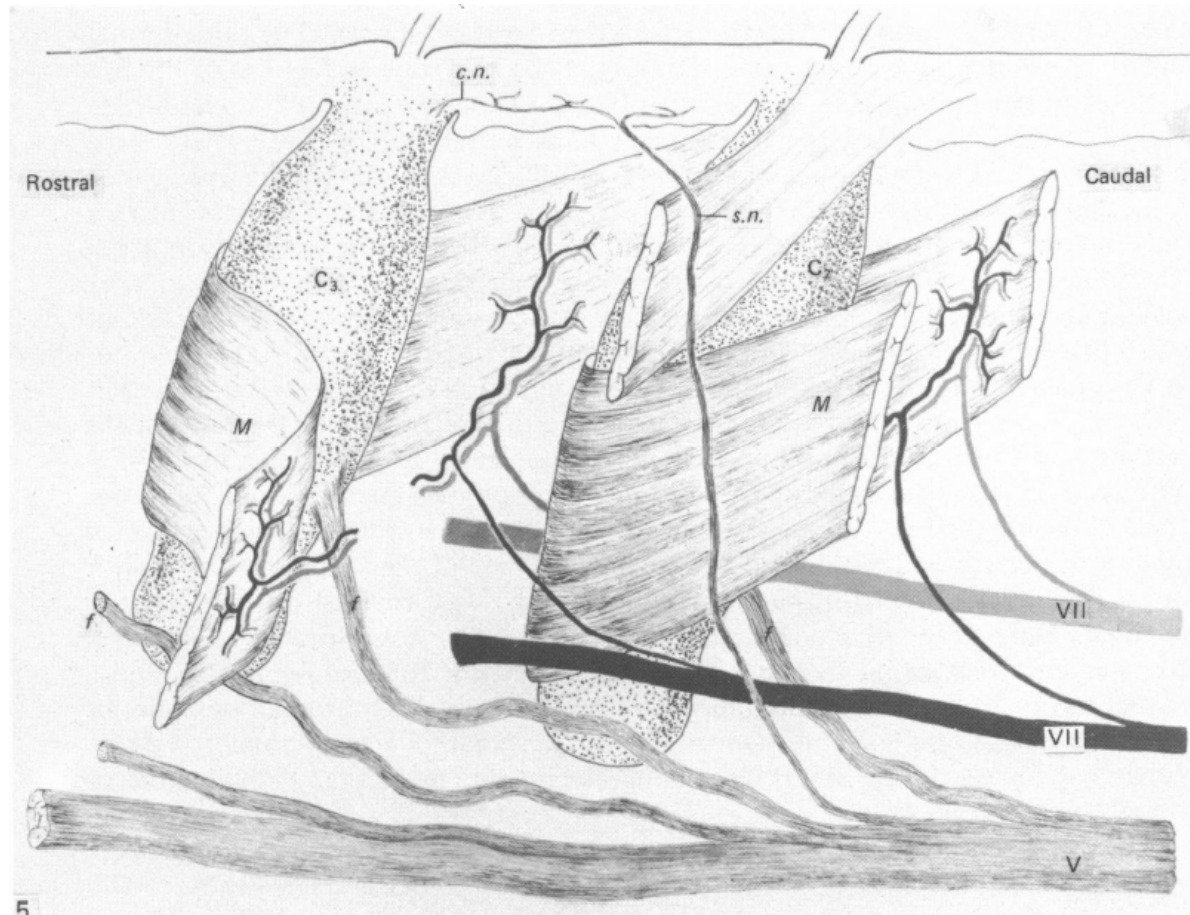

# Motor control of whiskers

## Intrinsic muscles

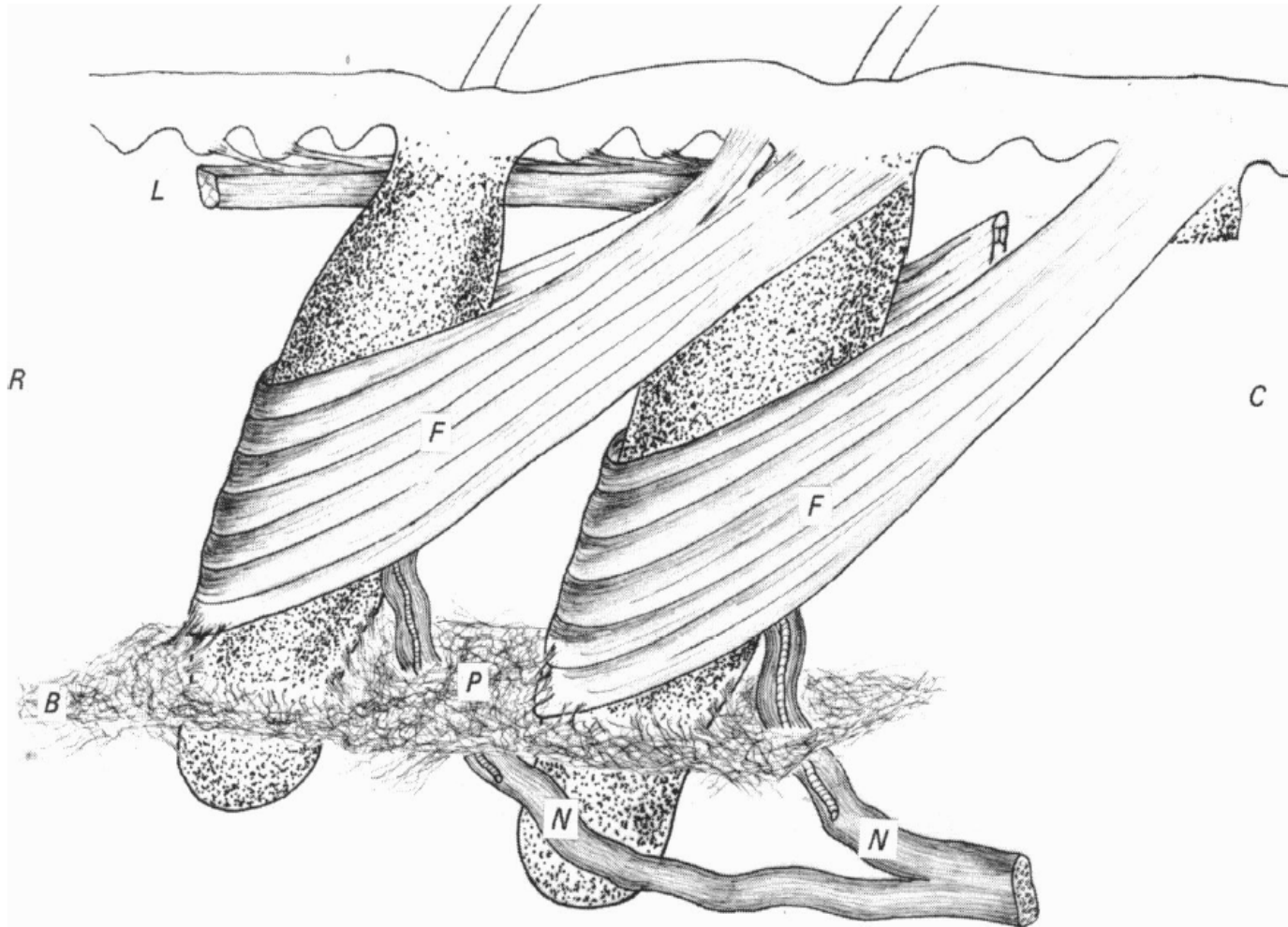

# Vibrissal proprioception

- Each follicle contains ~2000 receptors
- About 20% of them convey pure proprioceptive information

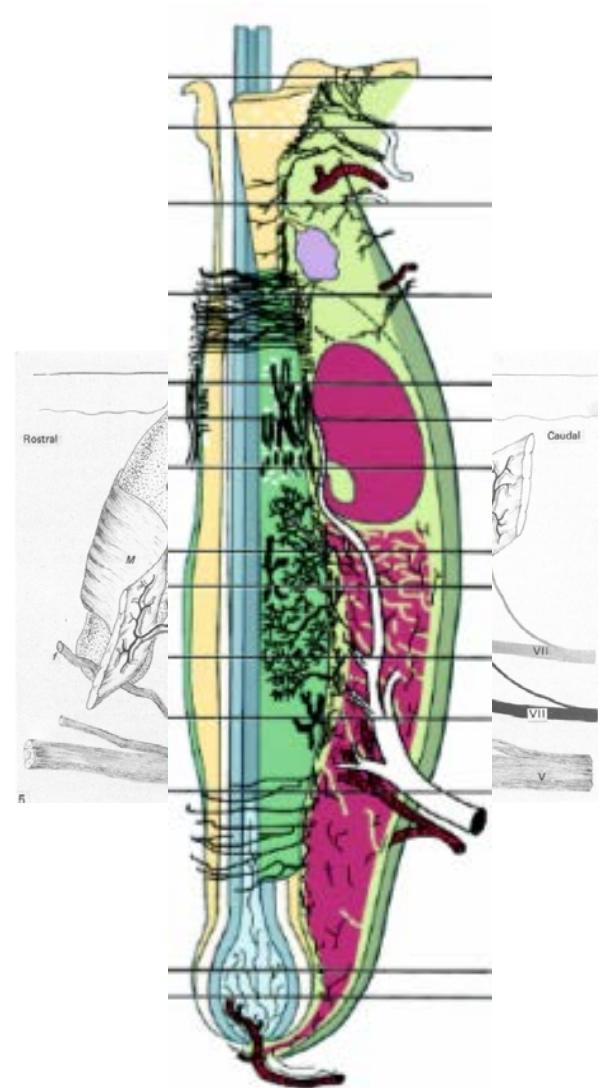

# Vibrissal system

## Proprioceptive loop

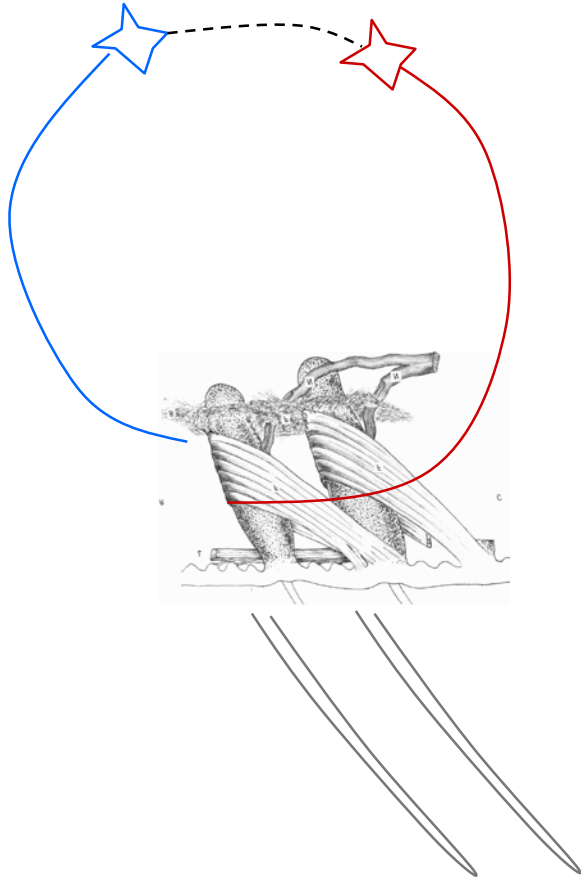

# Skeletal system

## Proprioceptive loop

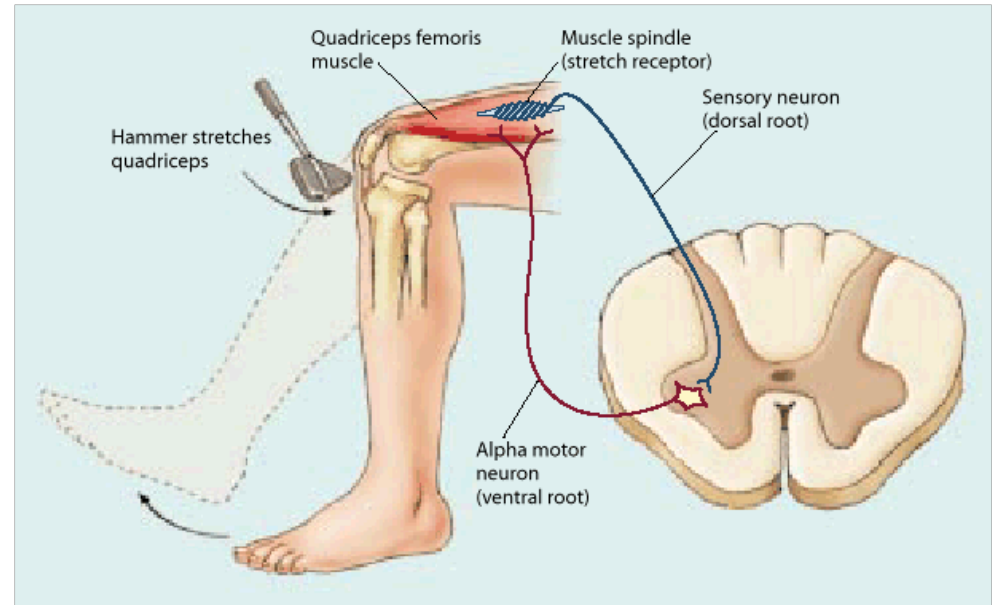

# Whiskers come with different muscle sizes

## Intrinsic muscles

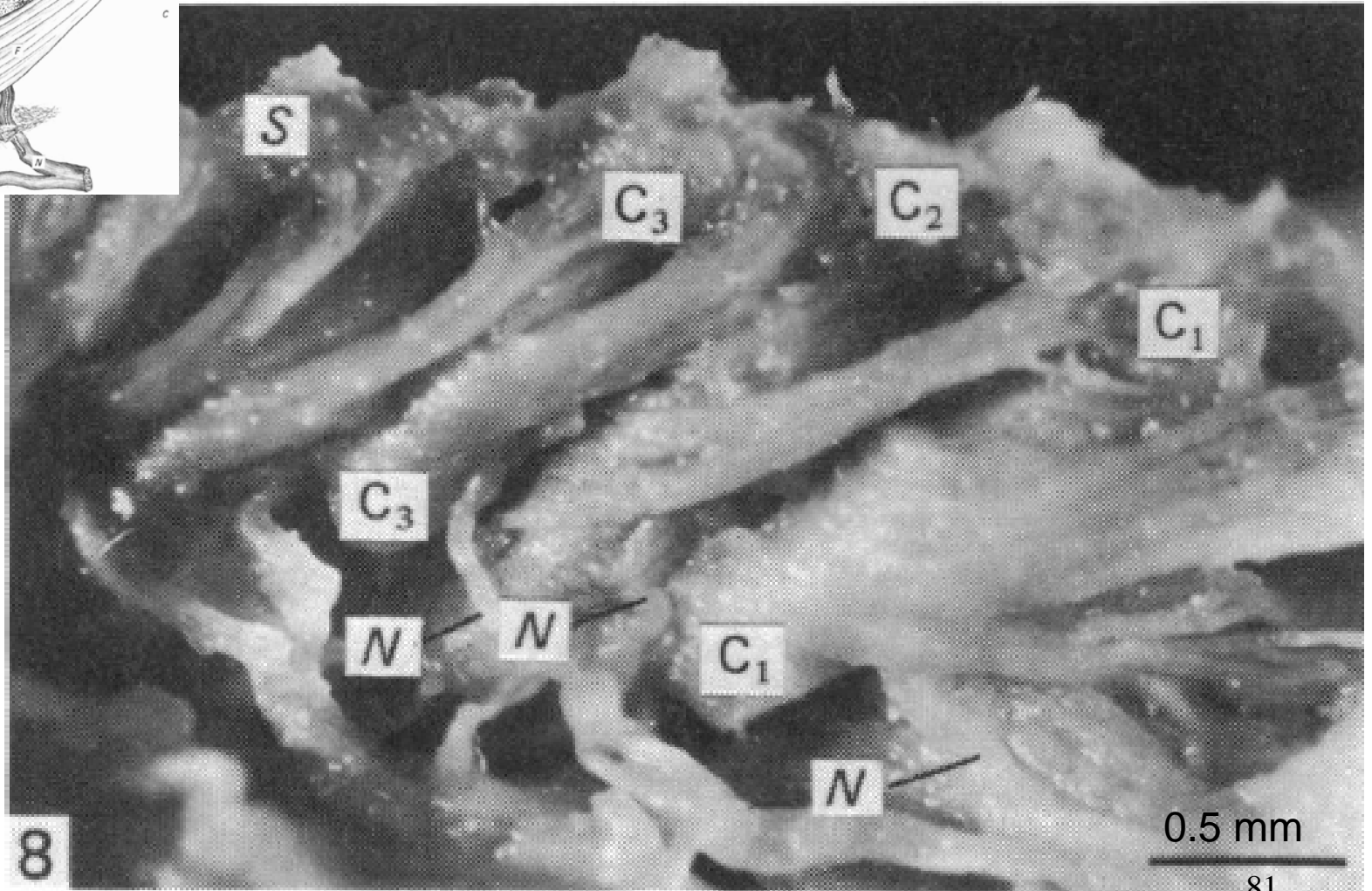
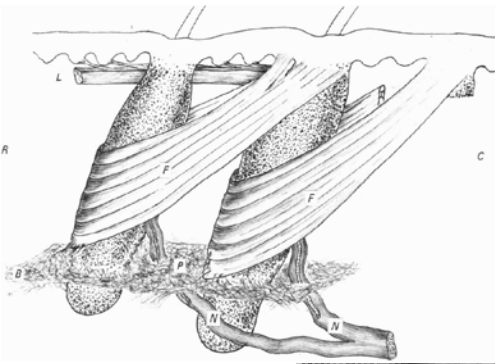

# Whisking behavior – reflections of control loops

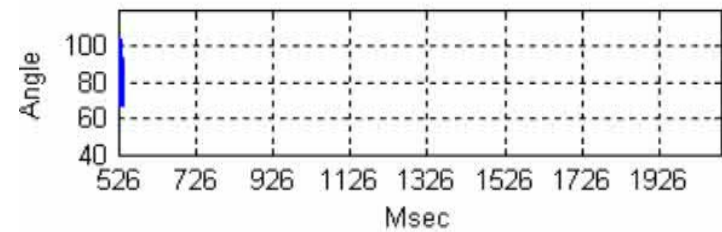
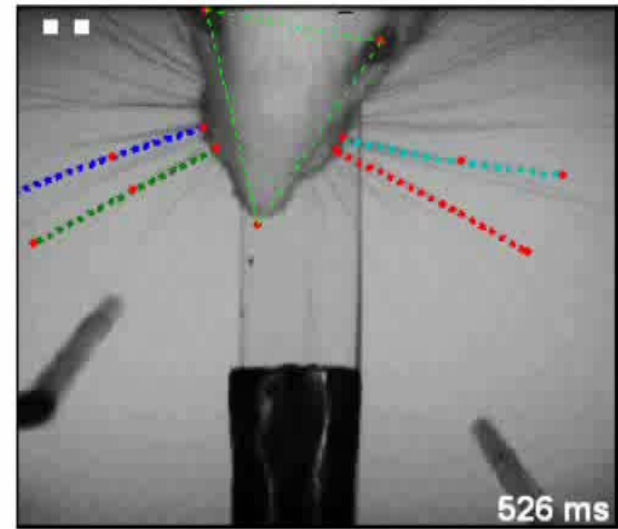
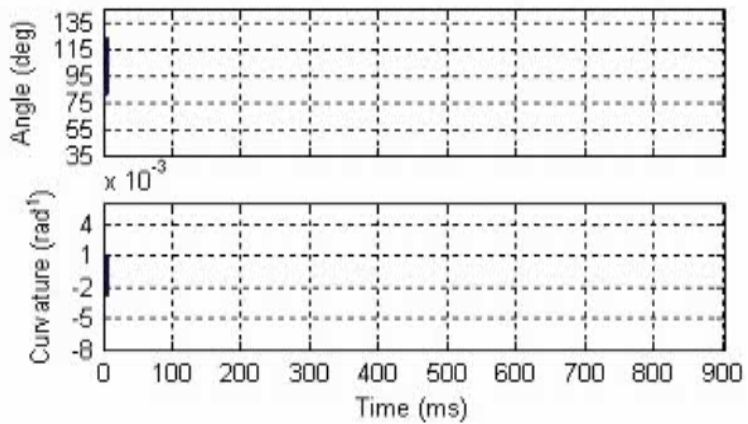
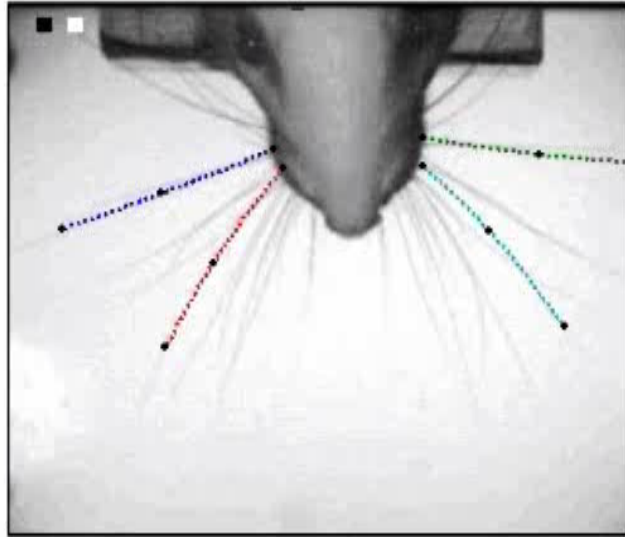

# Perception of external objects

## Object localization

- What signals must the brain process in order to infer a location of an external object in space?
- Reafferent + exafferent signals

# What the whiskers tell the rat brain

**Reafference:**

**Their own movement**

**(“Whisking”)**

**Exafference:**

**Touch**

# What the whiskers tell the rat brain

## Whisking

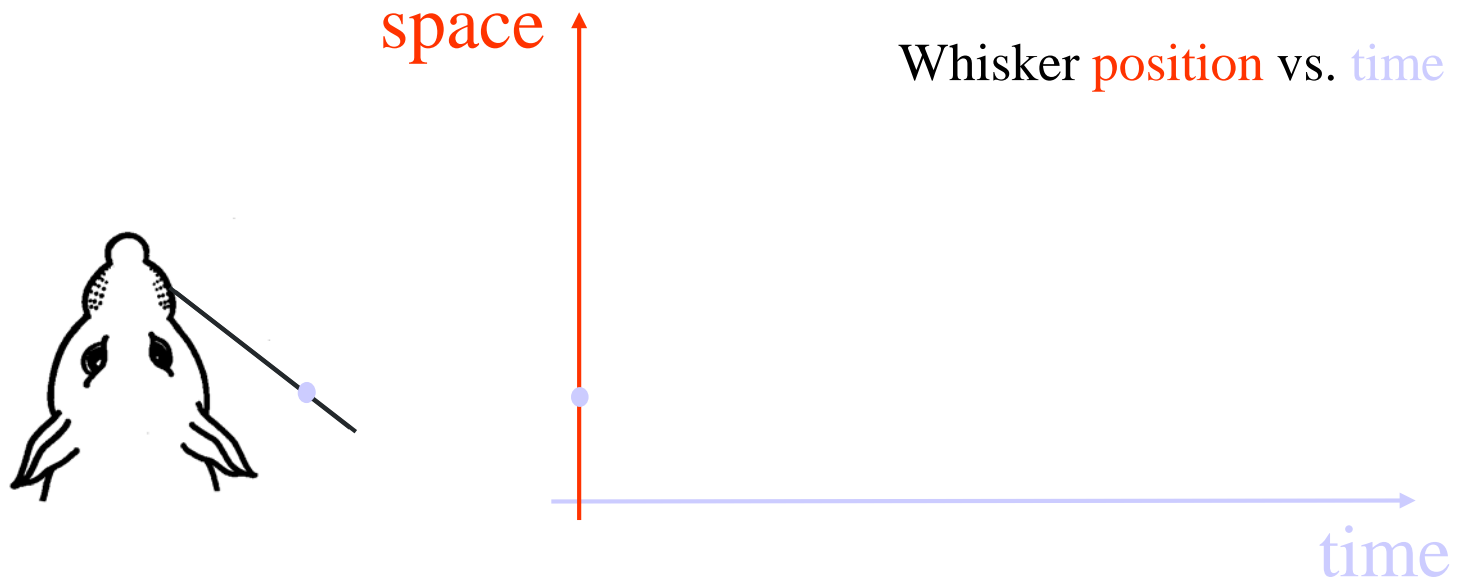

# What the whiskers tell the rat brain

## Whisking

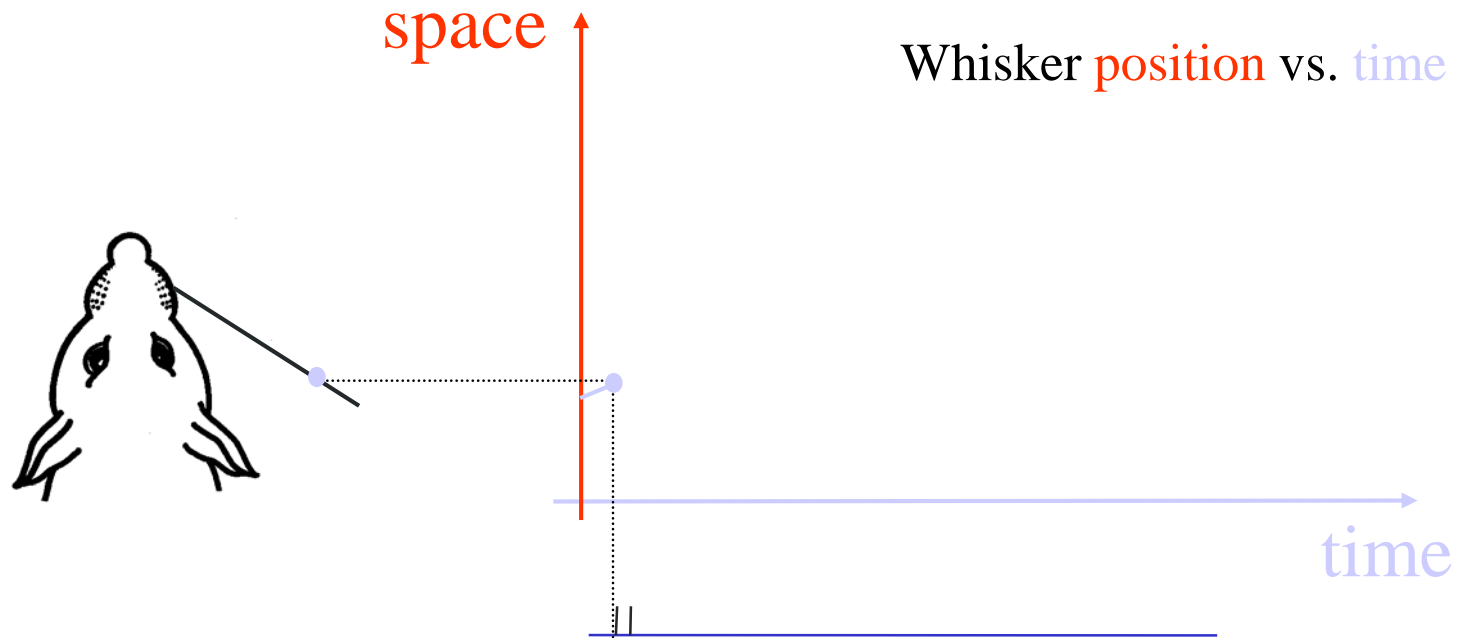

# What the whiskers tell the rat brain

## Whisking

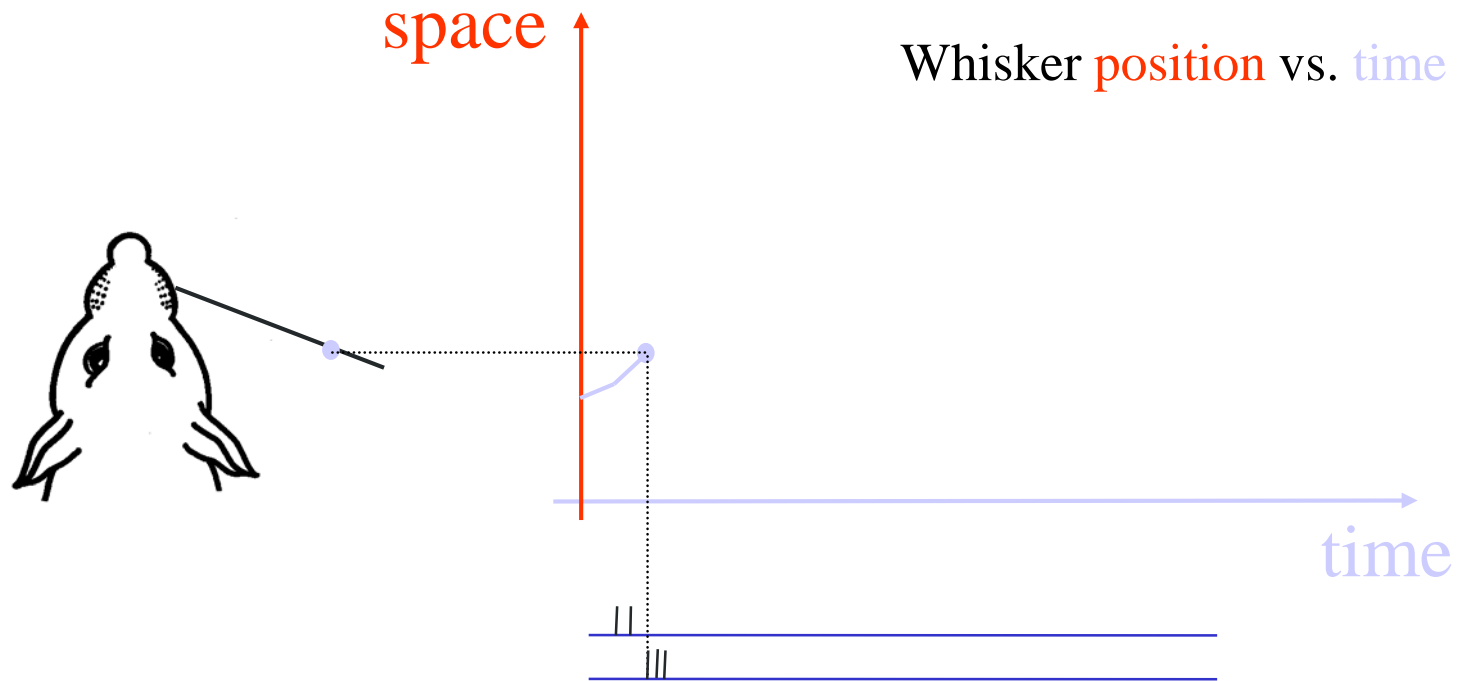

# What the whiskers tell the rat brain

## Whisking

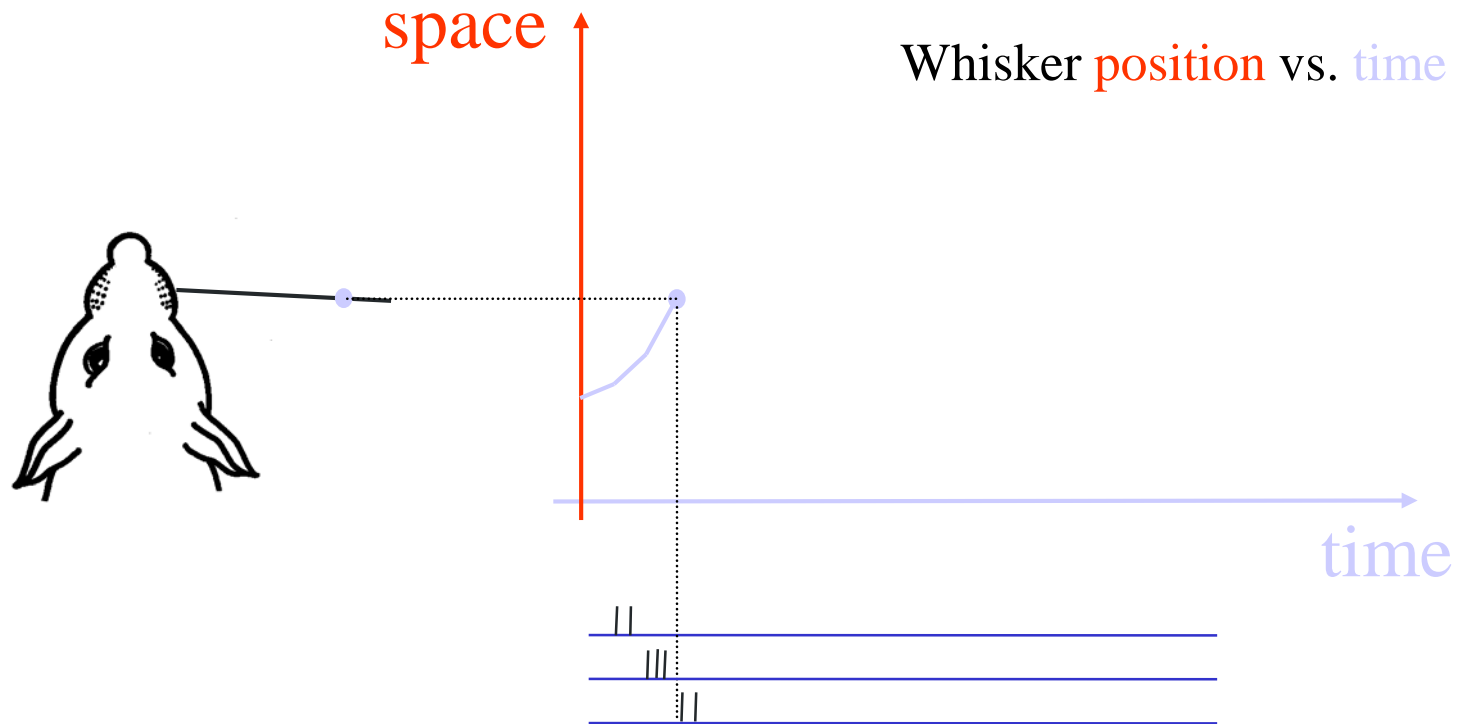

# What the whiskers tell the rat brain

## Whisking

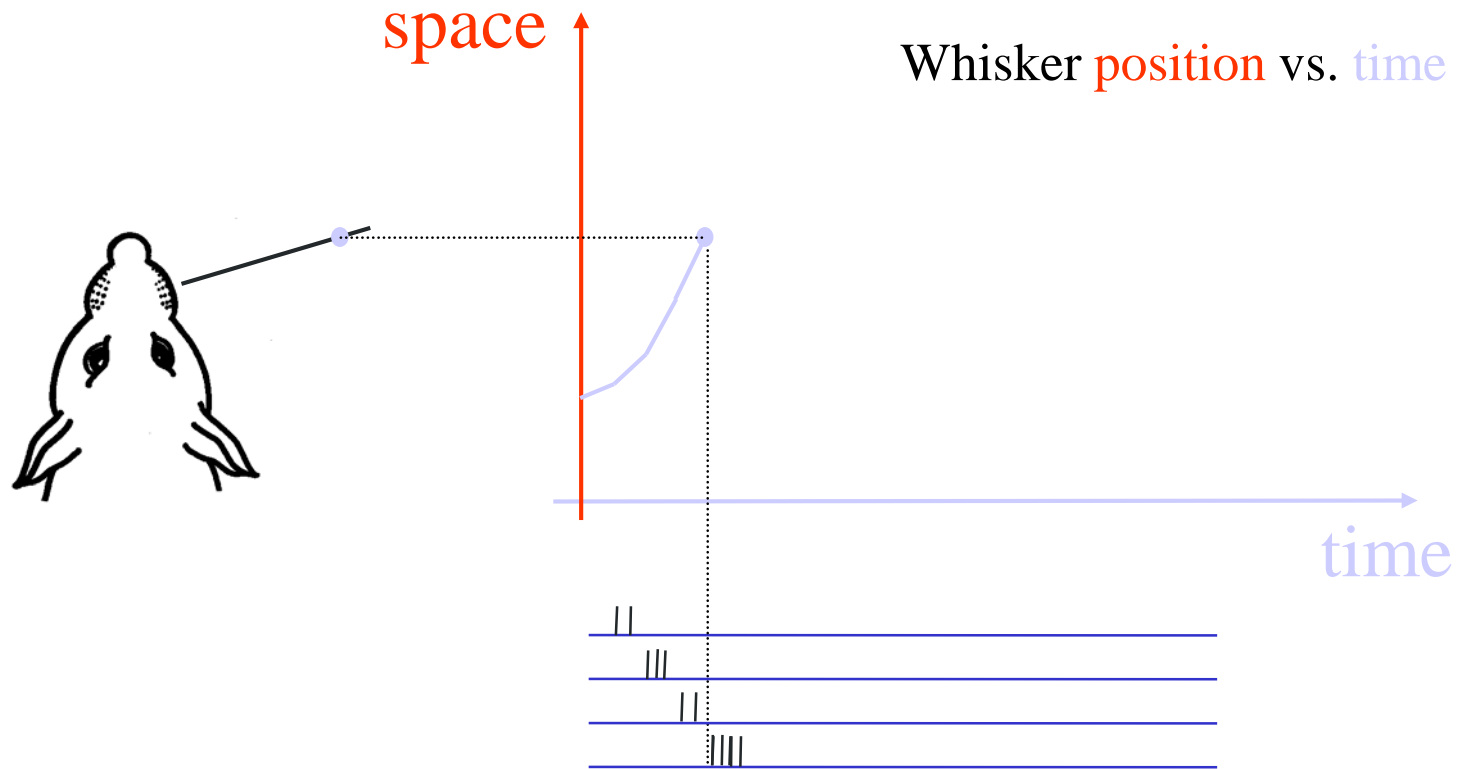

# What the whiskers tell the rat brain

## Whisking

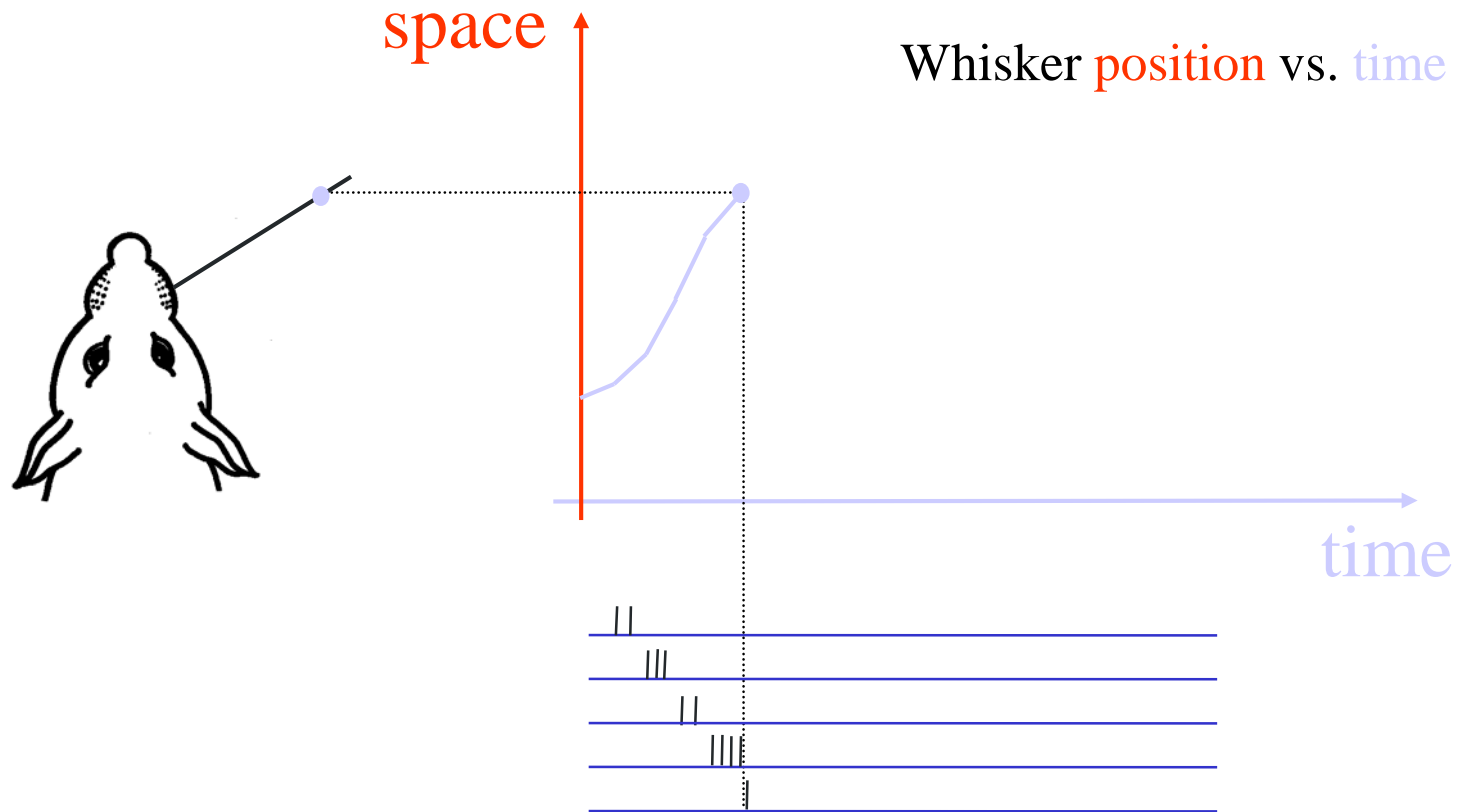

# What the whiskers tell the rat brain

## Whisking

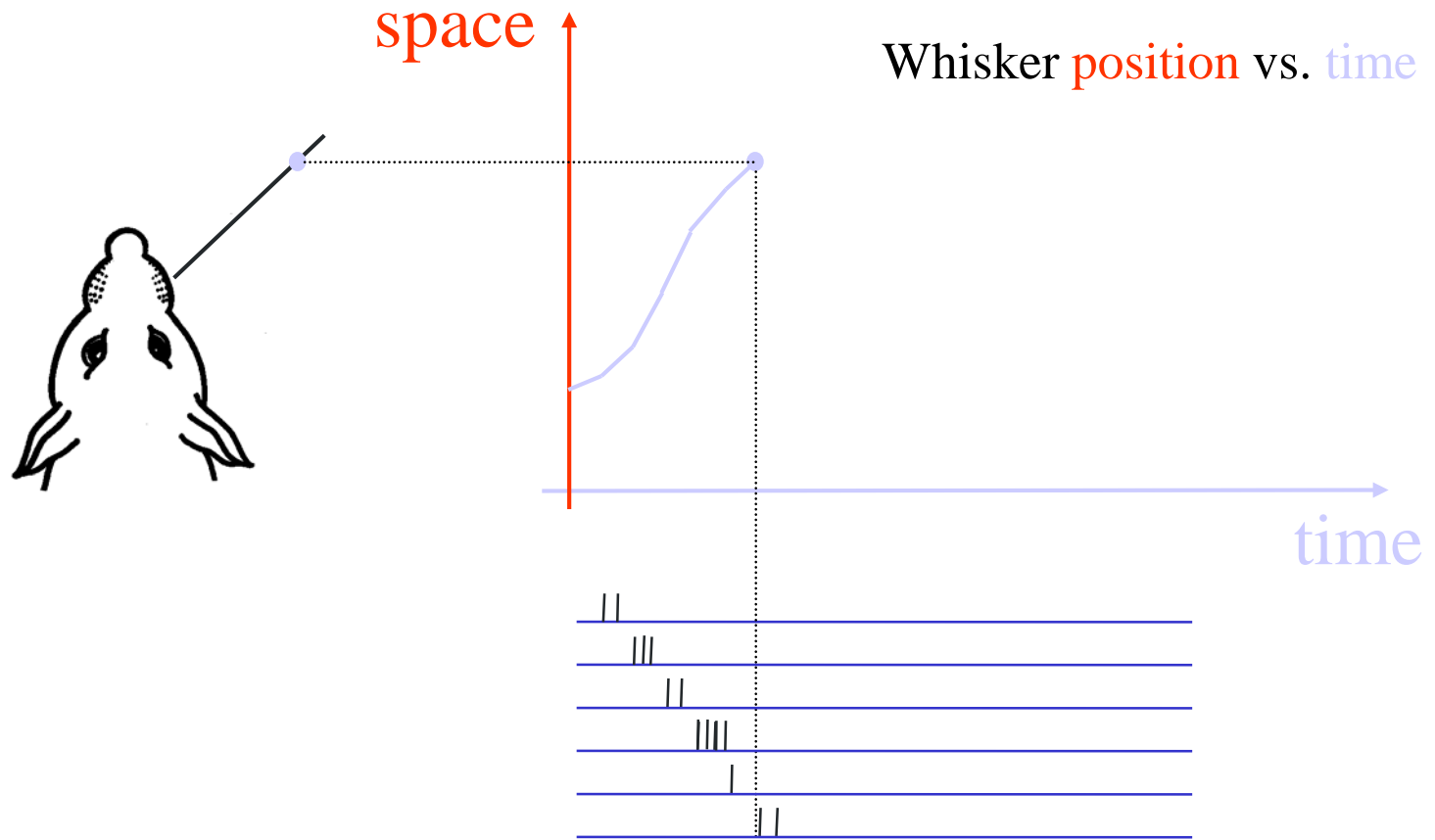

# What the whiskers tell the rat brain

## Whisking

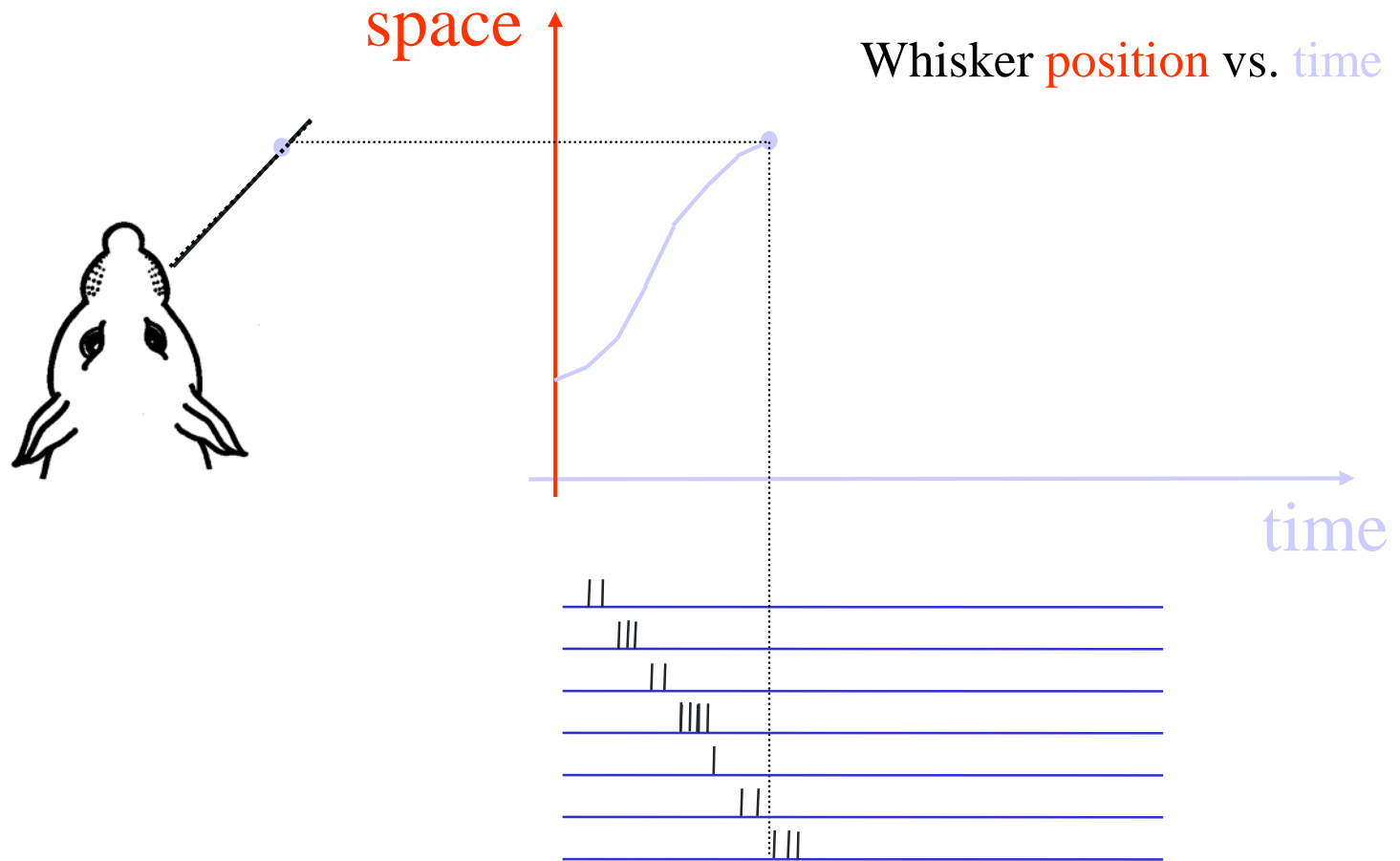

# What the whiskers tell the rat brain

## Whisking

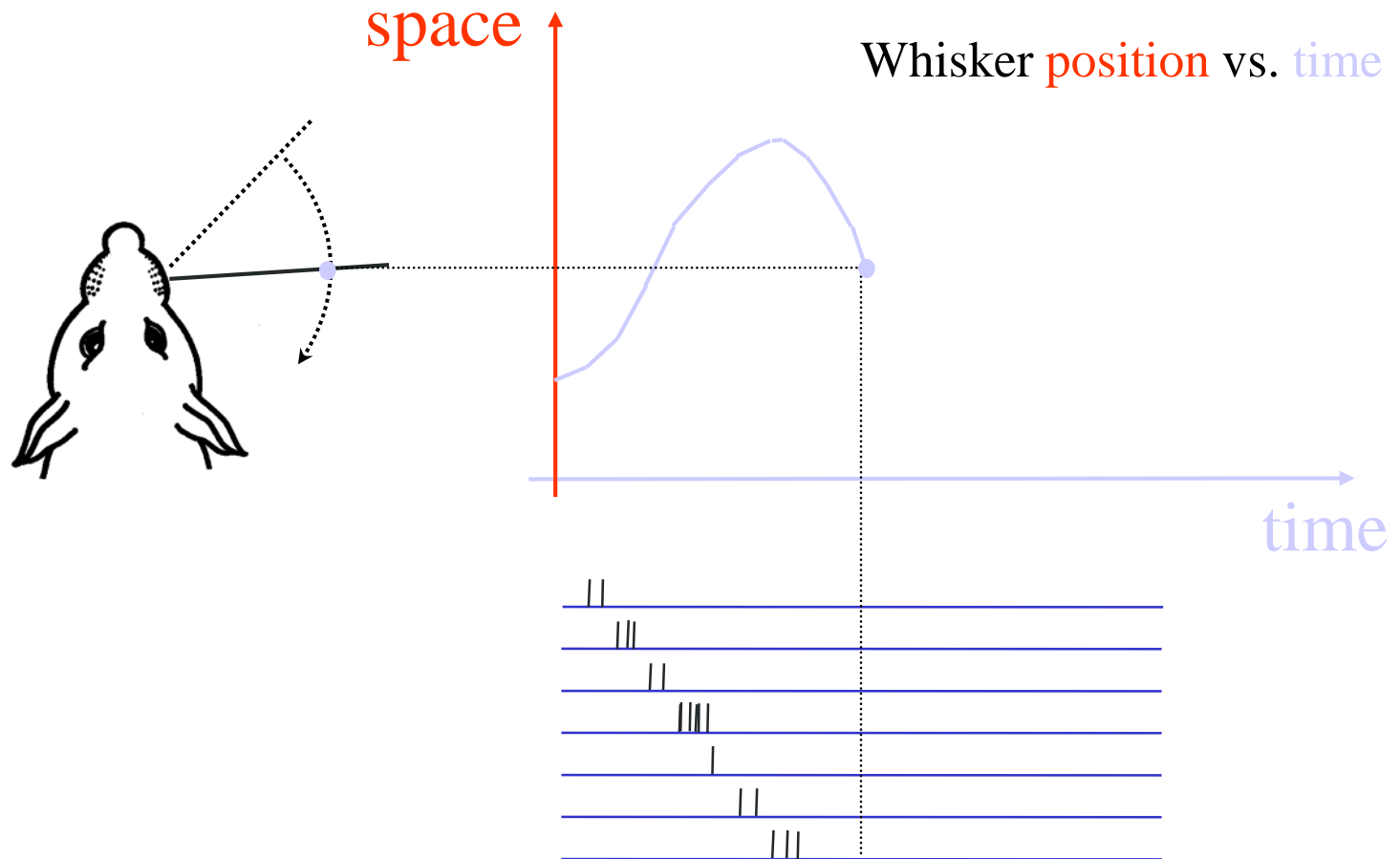

# What the whiskers tell the rat brain

## Whisking

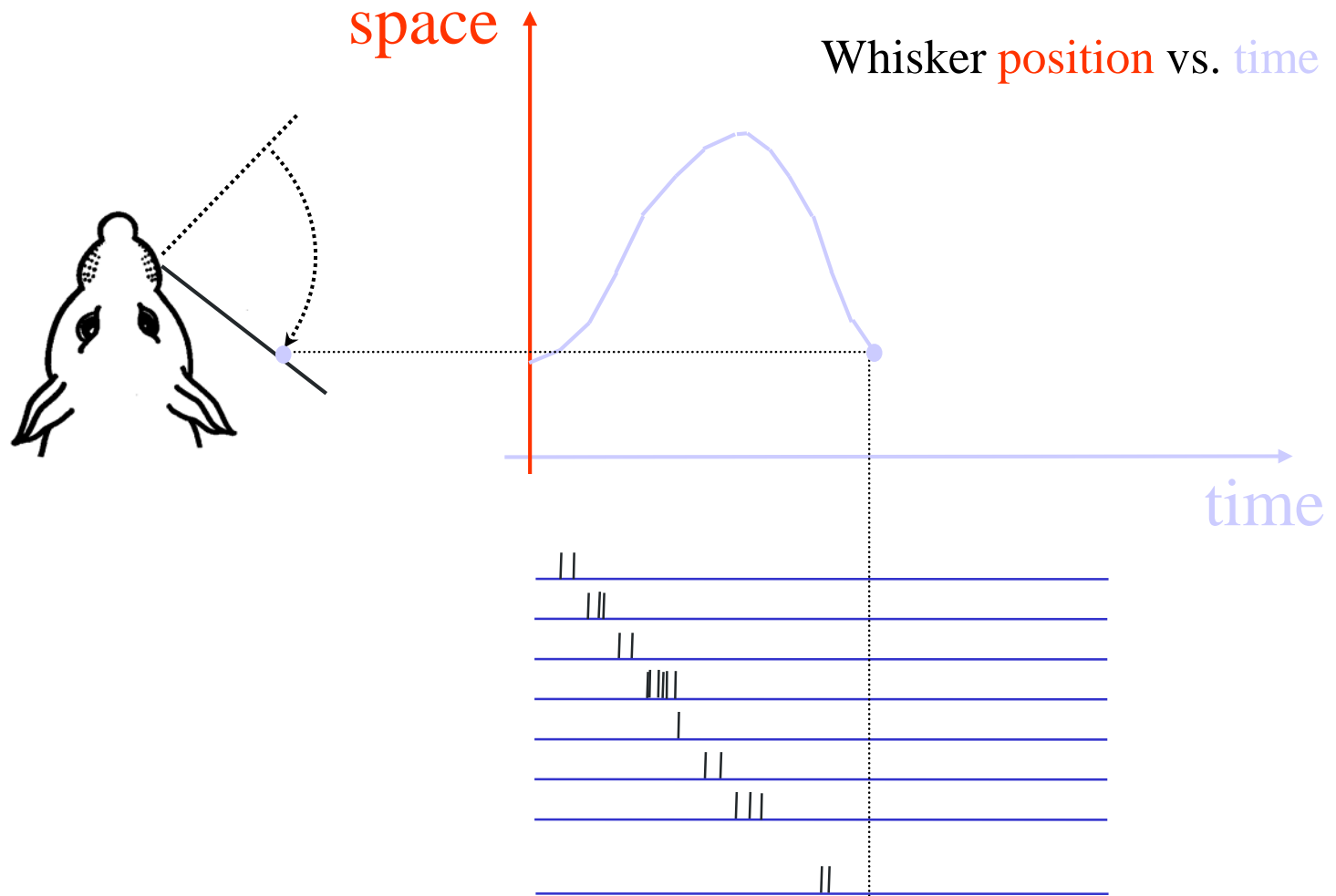

# What the whiskers tell the rat brain

## Whisking

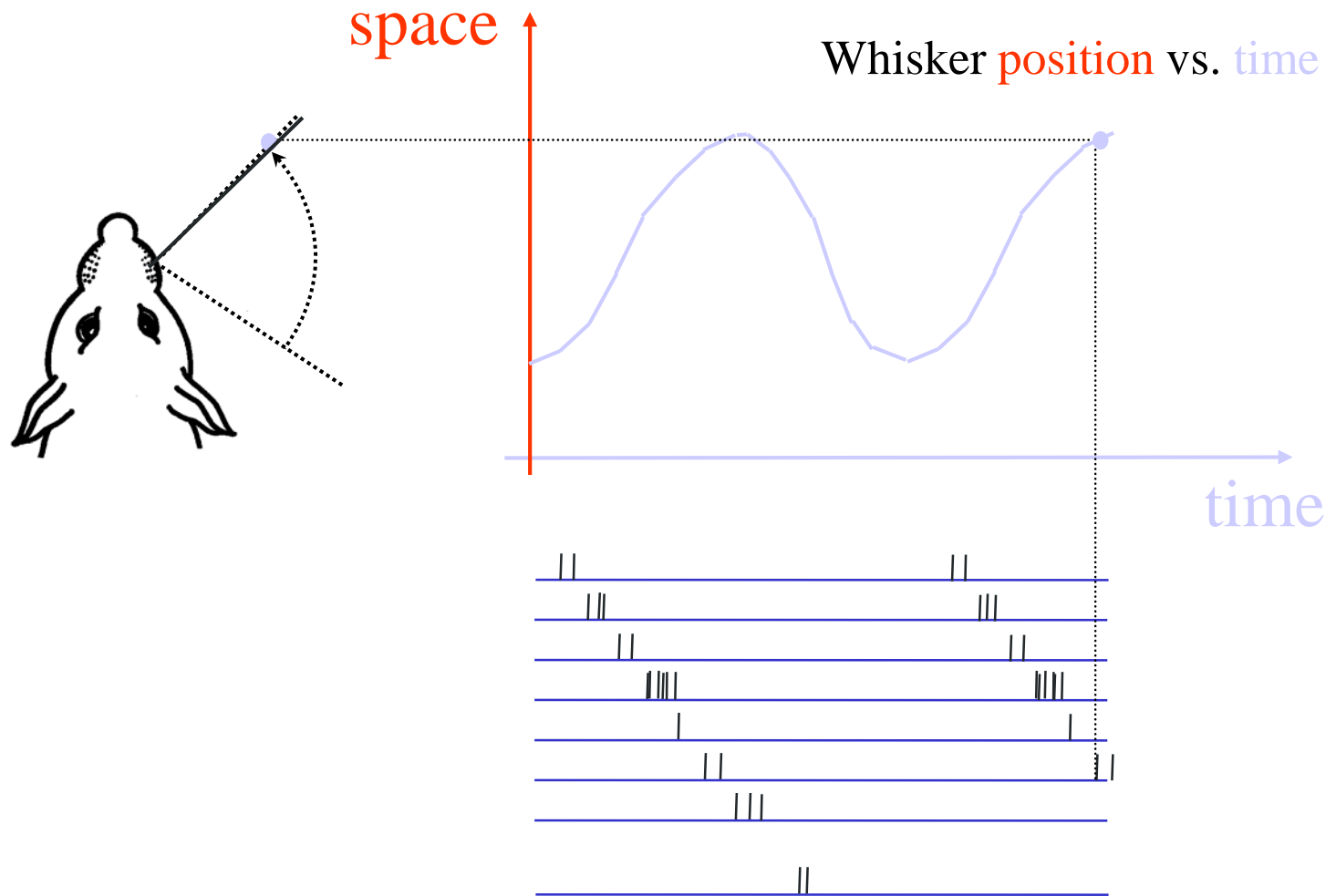

# What the whiskers tell the rat brain

Reafference:

Their own movement

(“Whisking”)

Exafference:

Touch

# What the whiskers tell the rat brain

## Touch



# What the whiskers tell the rat brain

## Touch

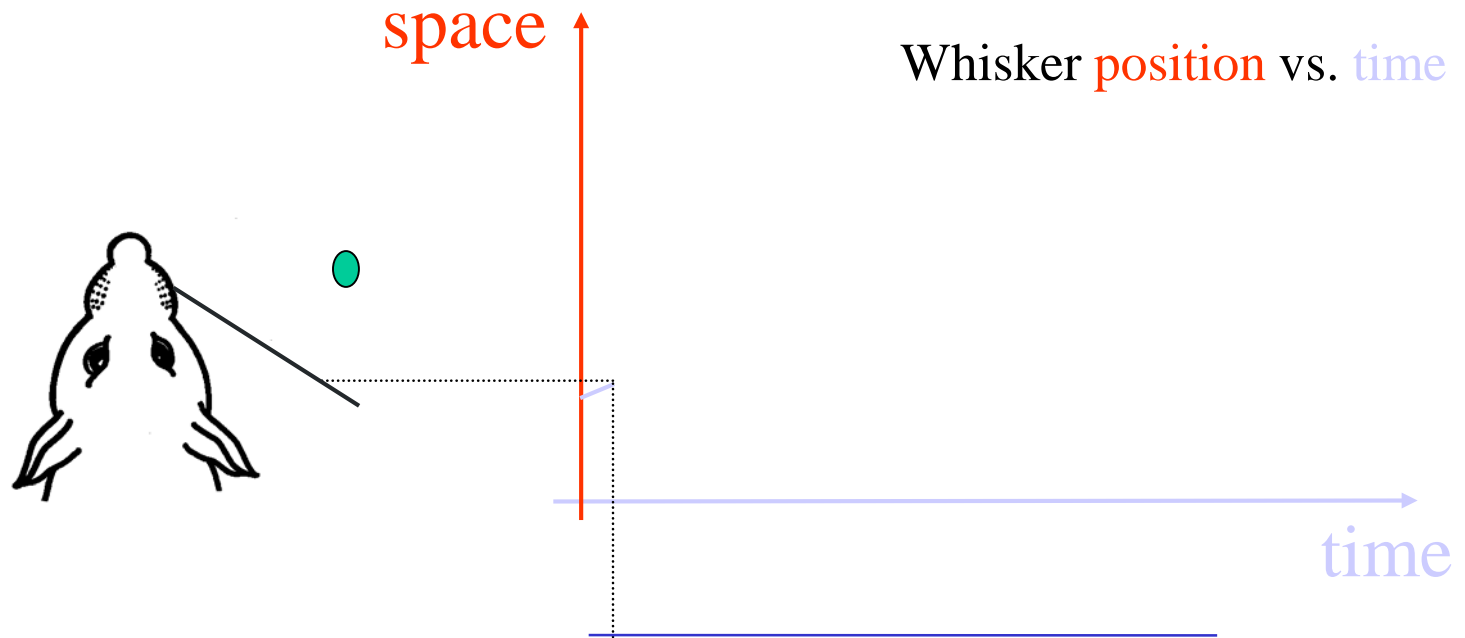

# What the whiskers tell the rat brain

## Touch

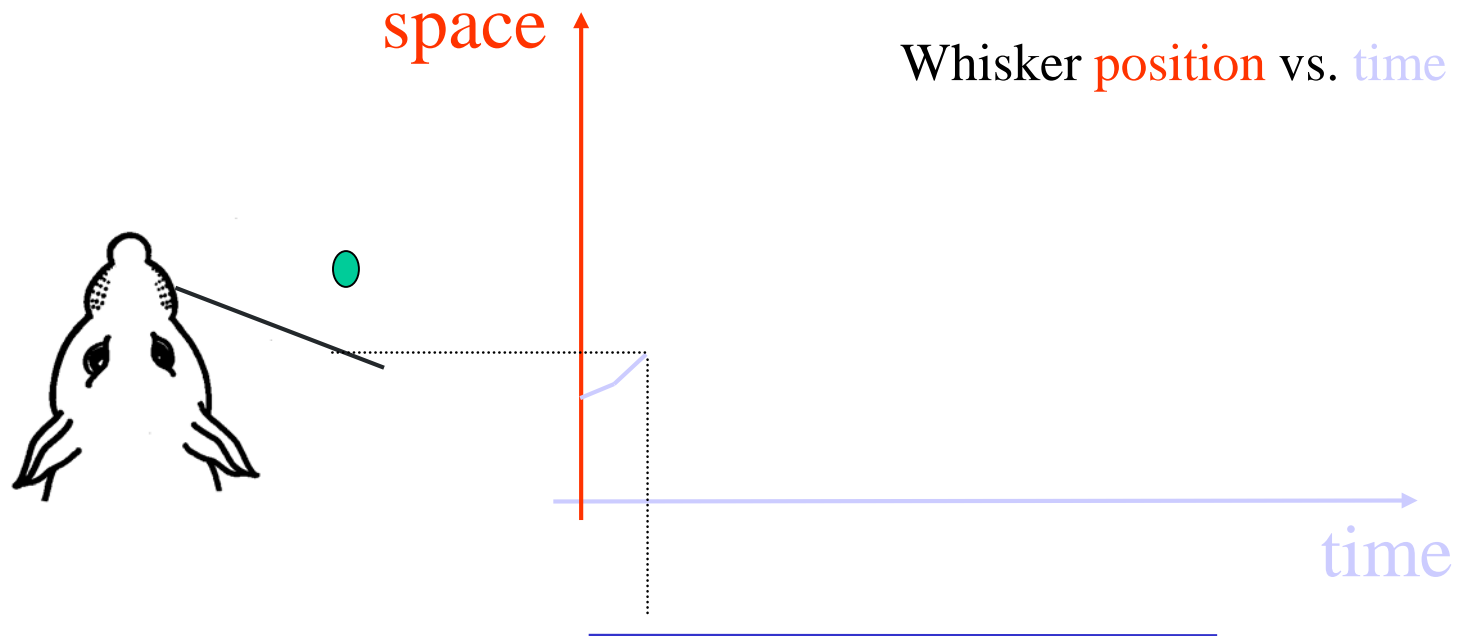

# What the whiskers tell the rat brain

## Touch

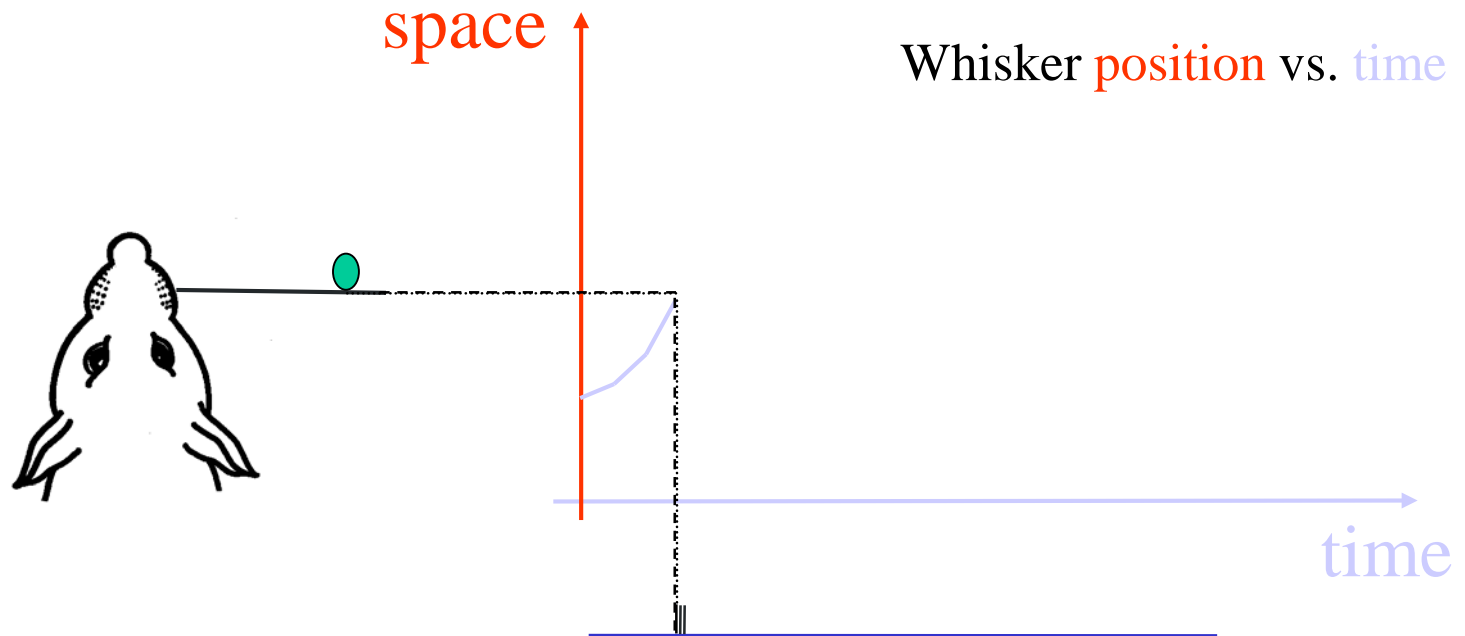

# What the whiskers tell the rat brain

## Touch

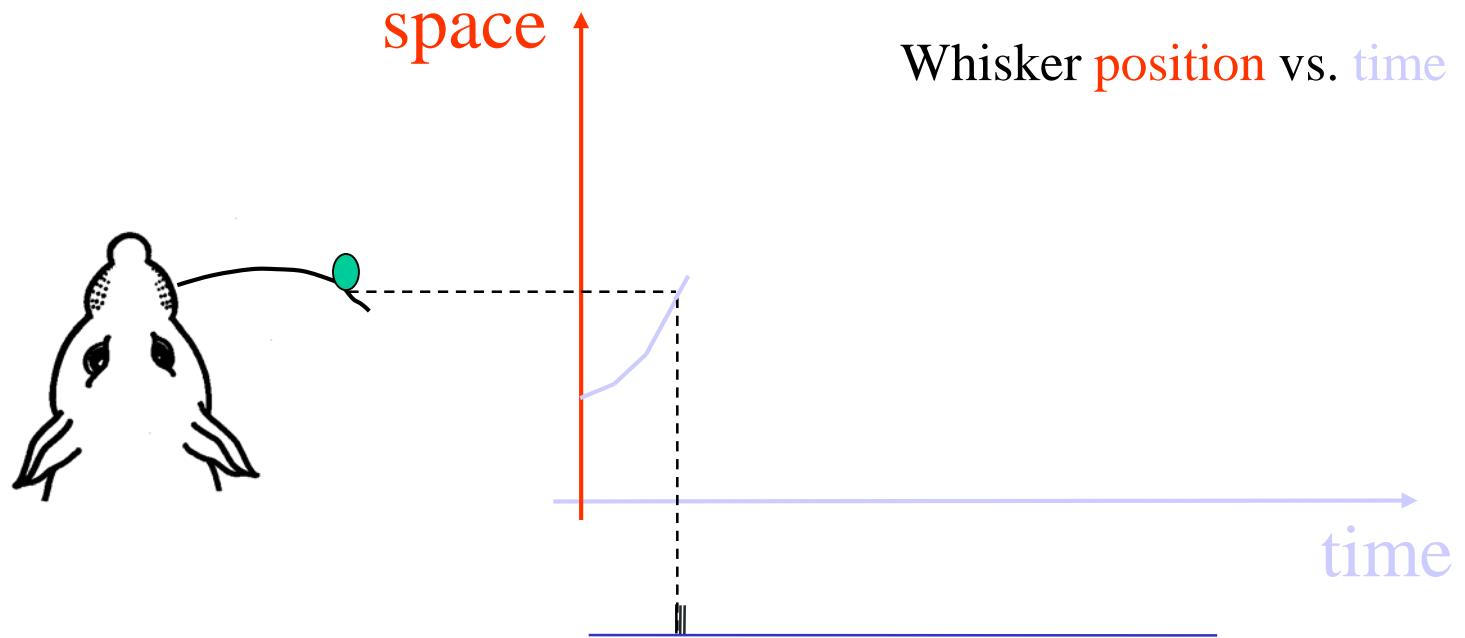

# What the whiskers tell the rat brain

## Touch

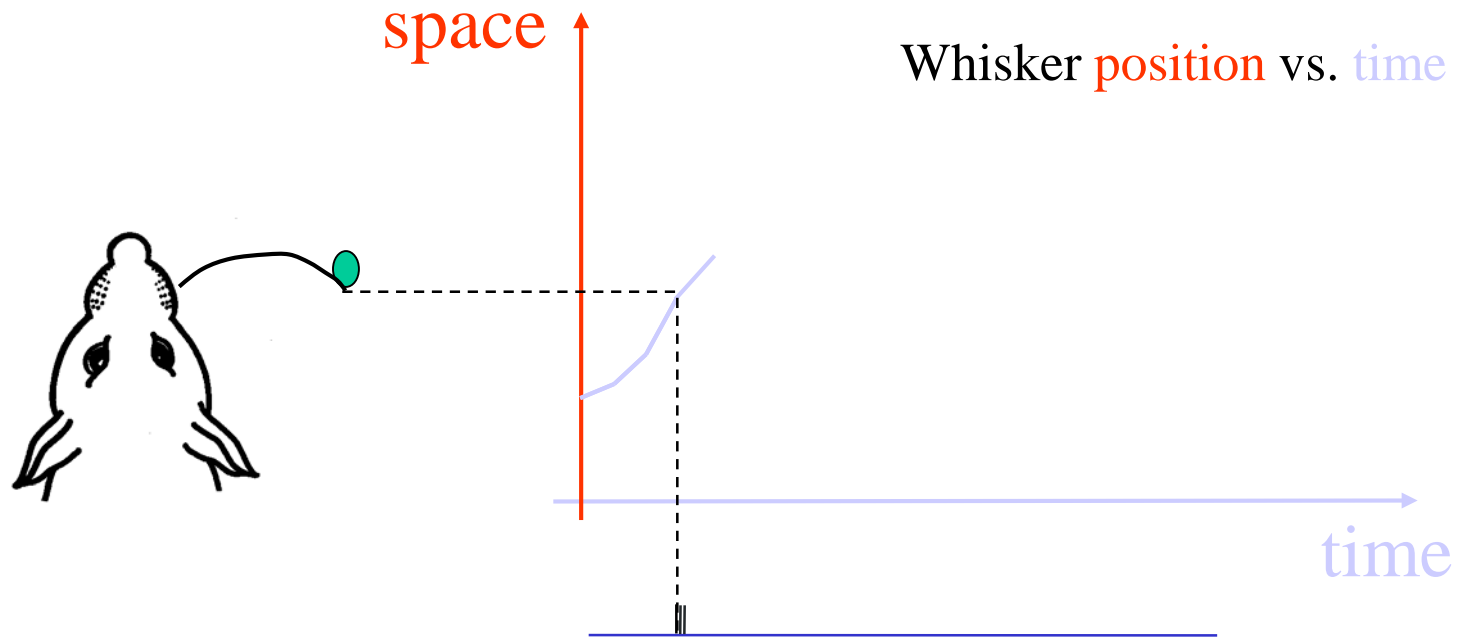

# What the whiskers tell the rat brain

## Touch

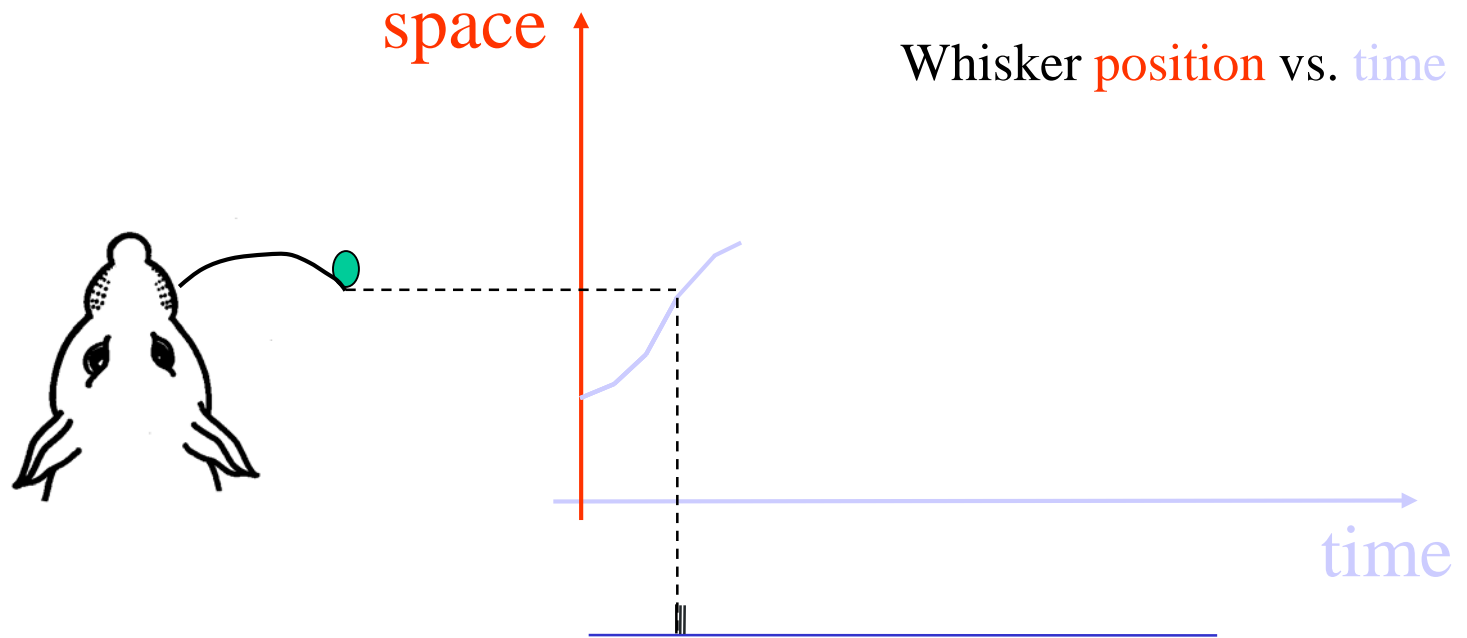

# What the whiskers tell the rat brain

## Touch

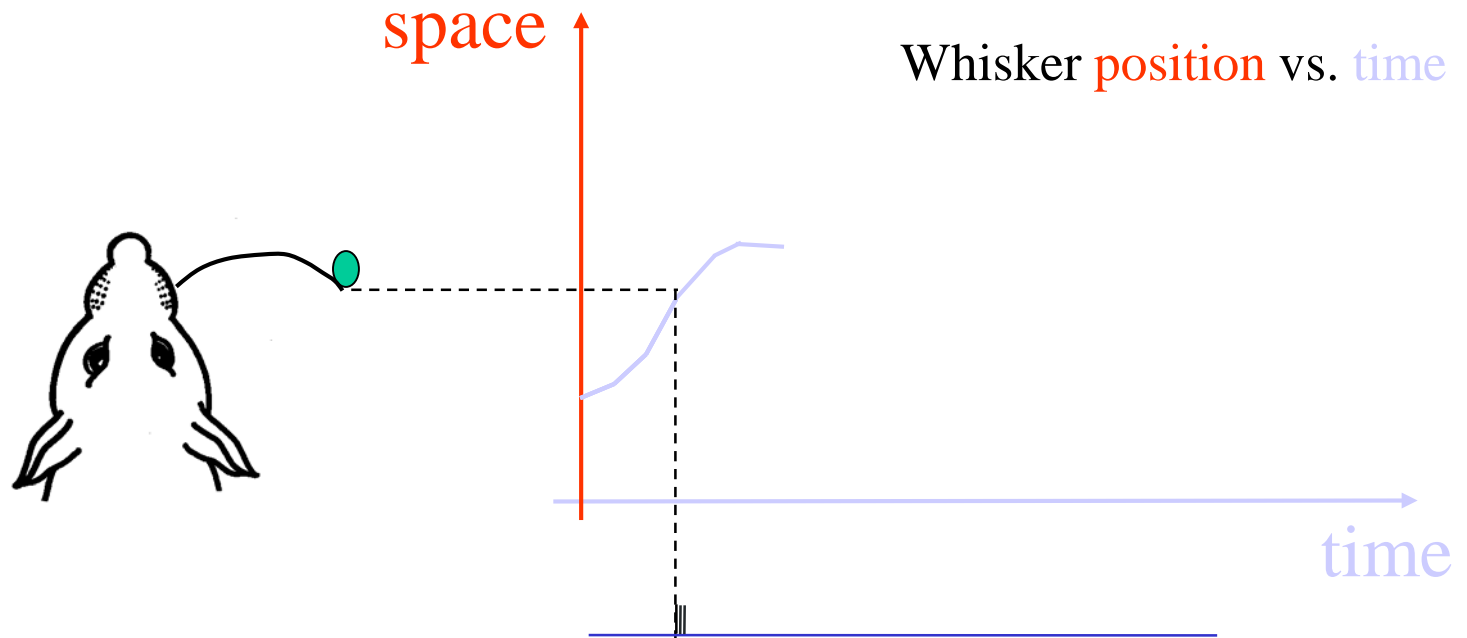

# What the whiskers tell the rat brain

## Touch

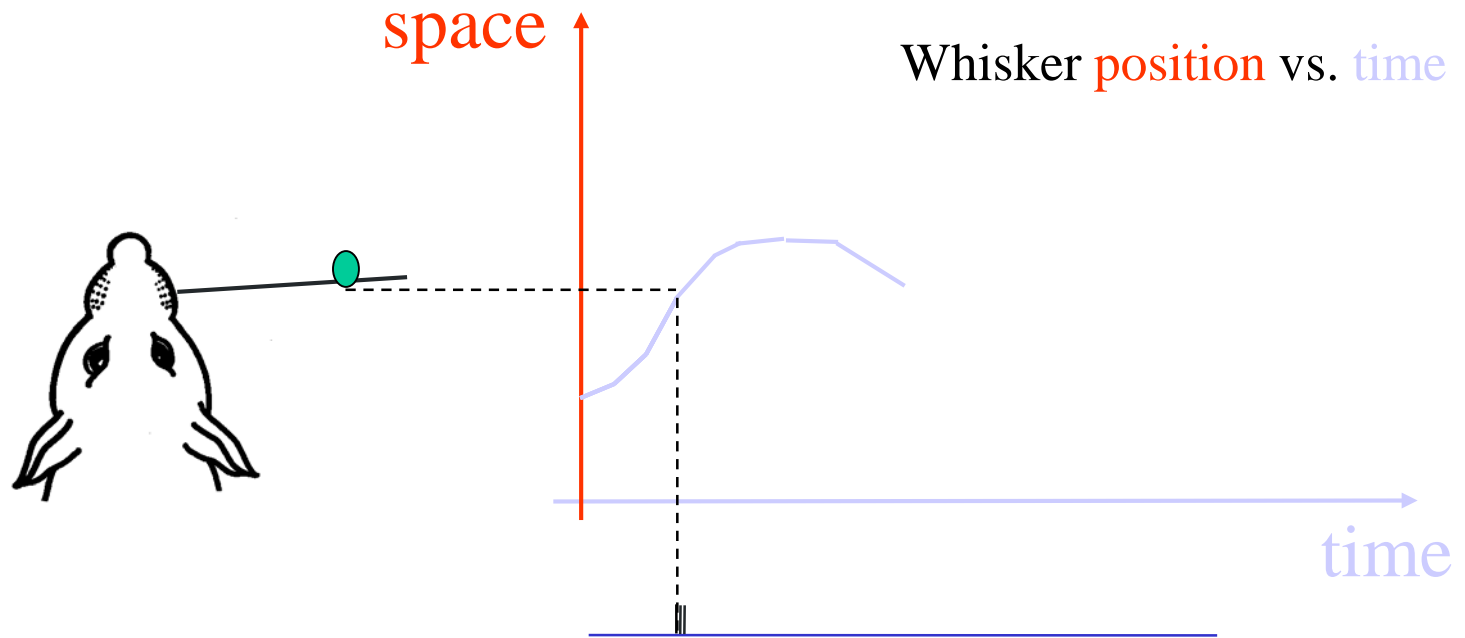

# What the whiskers tell the rat brain

## Touch

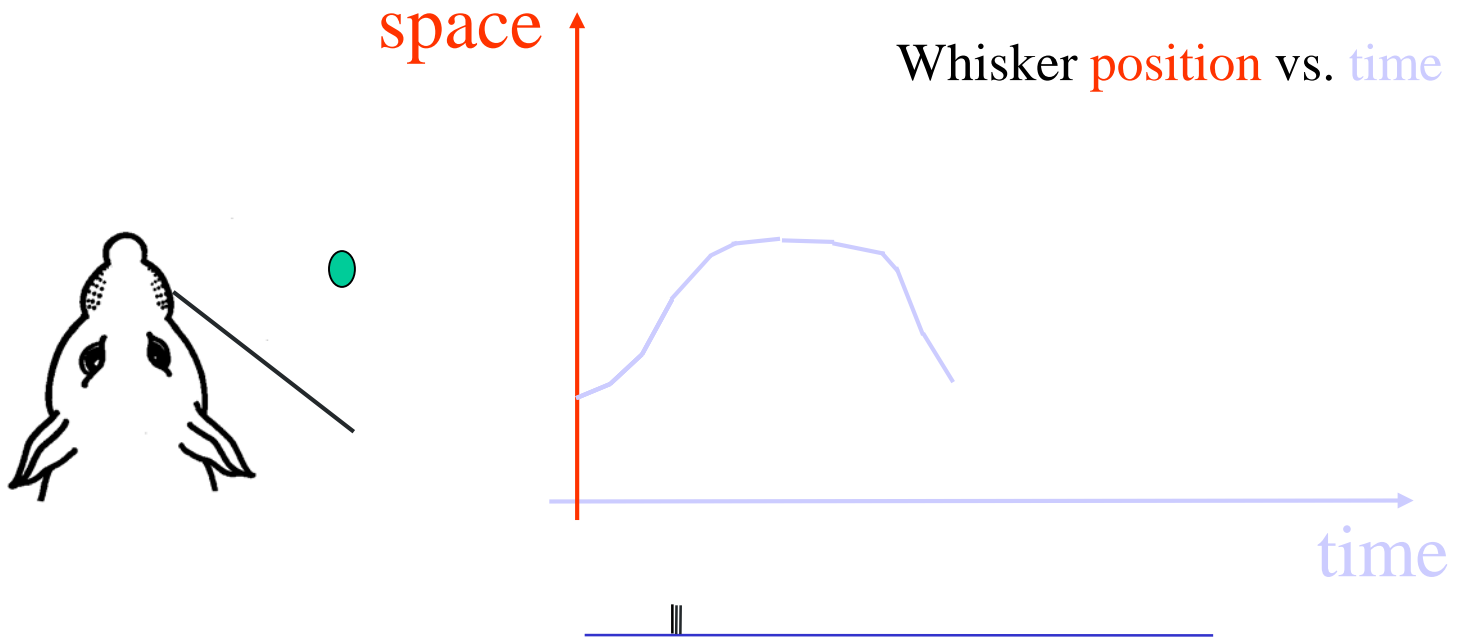

# What the whiskers tell the rat brain

## Touch

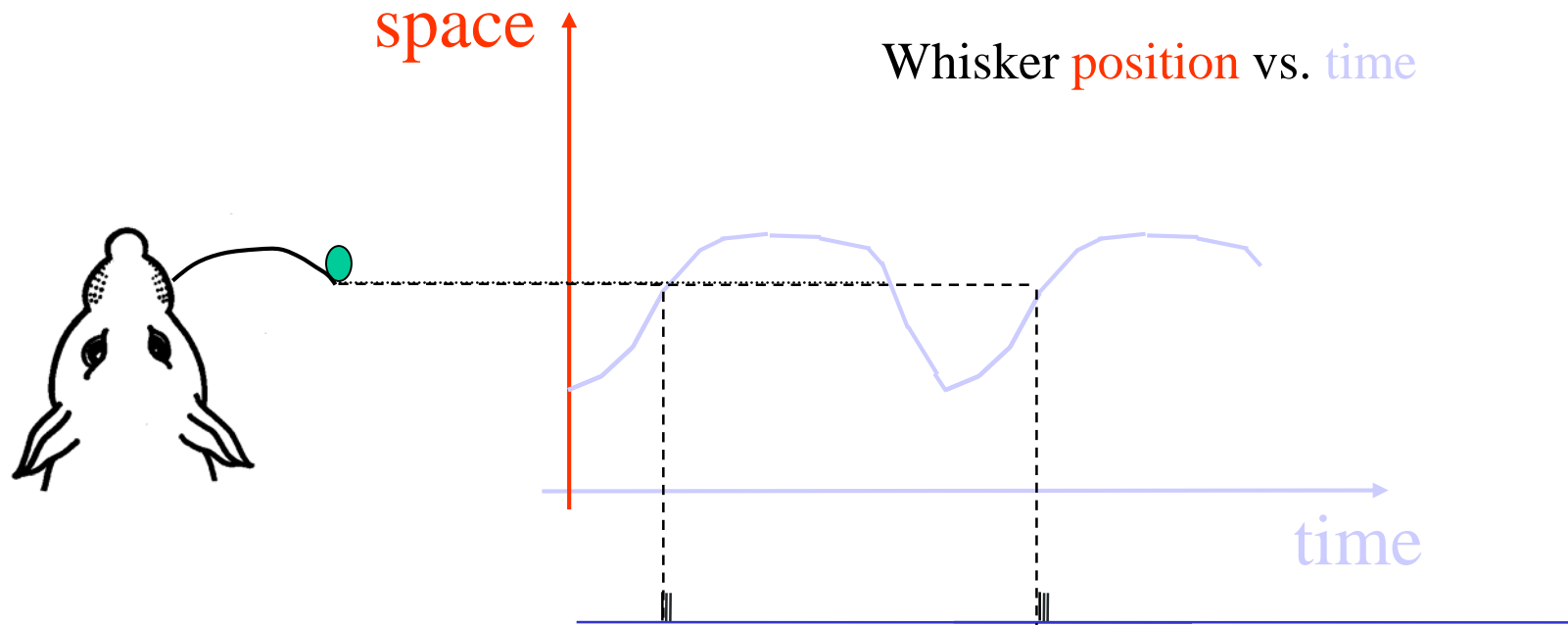

# What the whiskers tell the rat brain

## How can the brain use this information?

- Whisking:

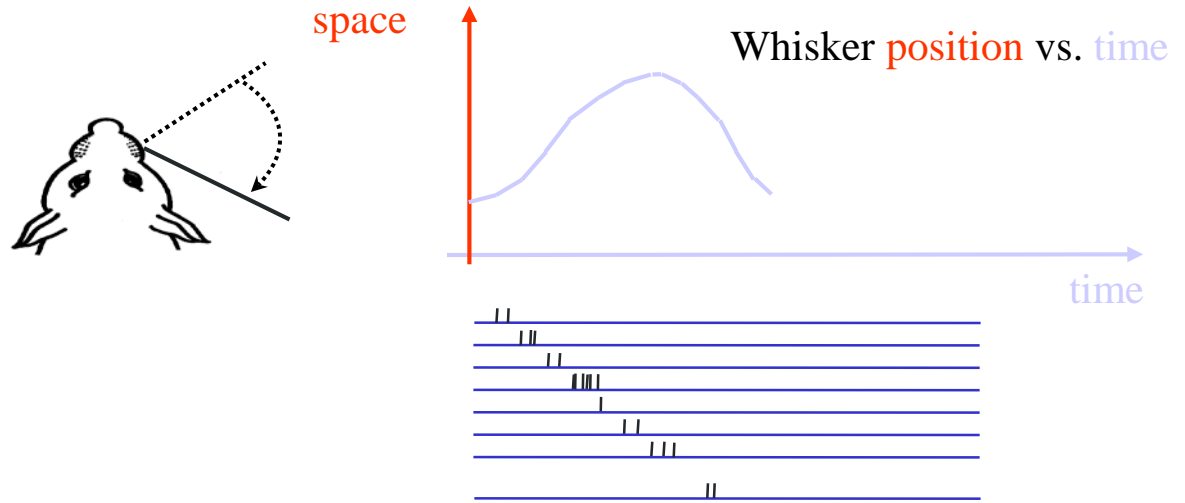

- Touch:

contact with object

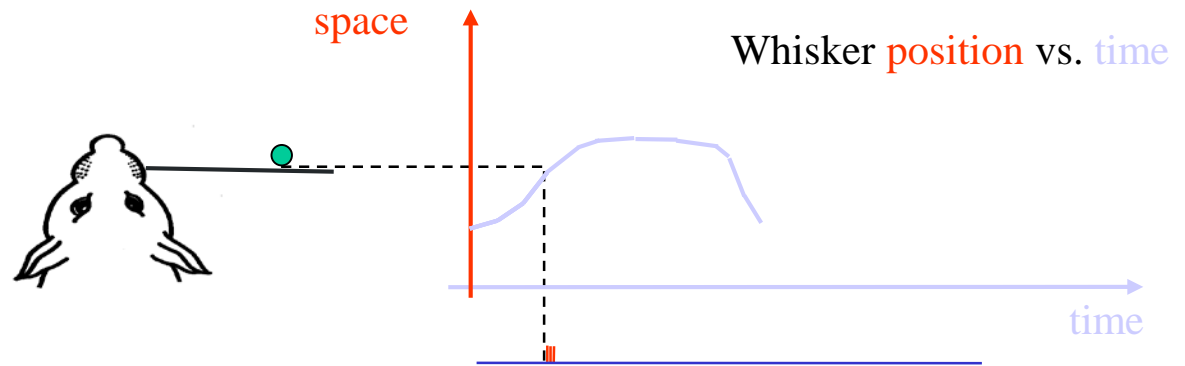

## What the whiskers tell the rat brain

### How can the brain use this information?

- Whisking:

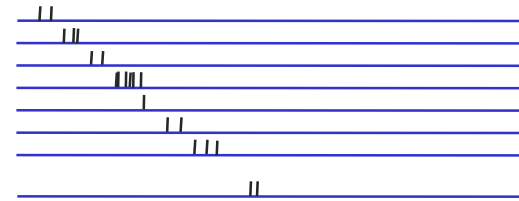
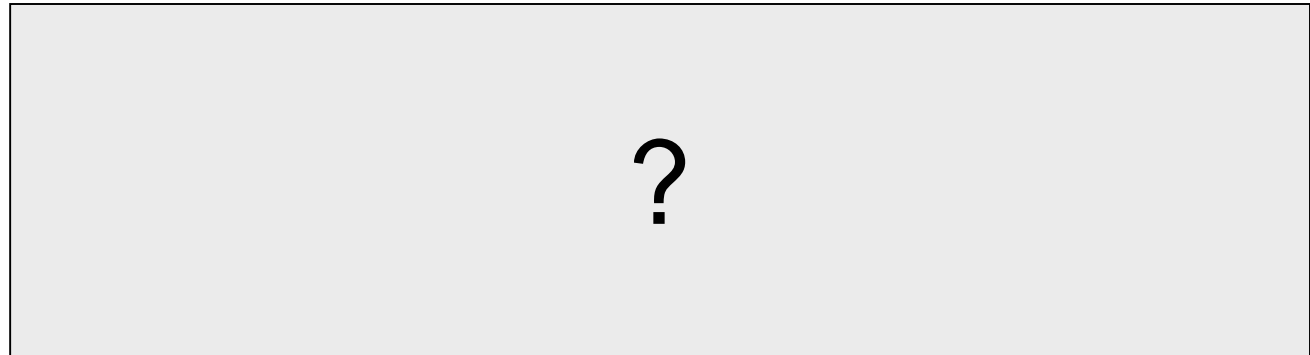

- Touch:

contact with object

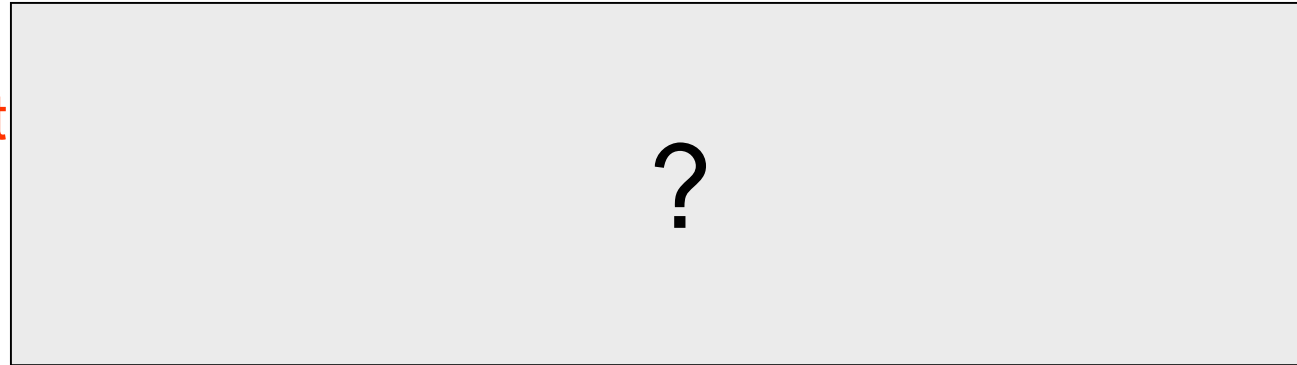

# How can the brain extract the location of the object

- Whisking:

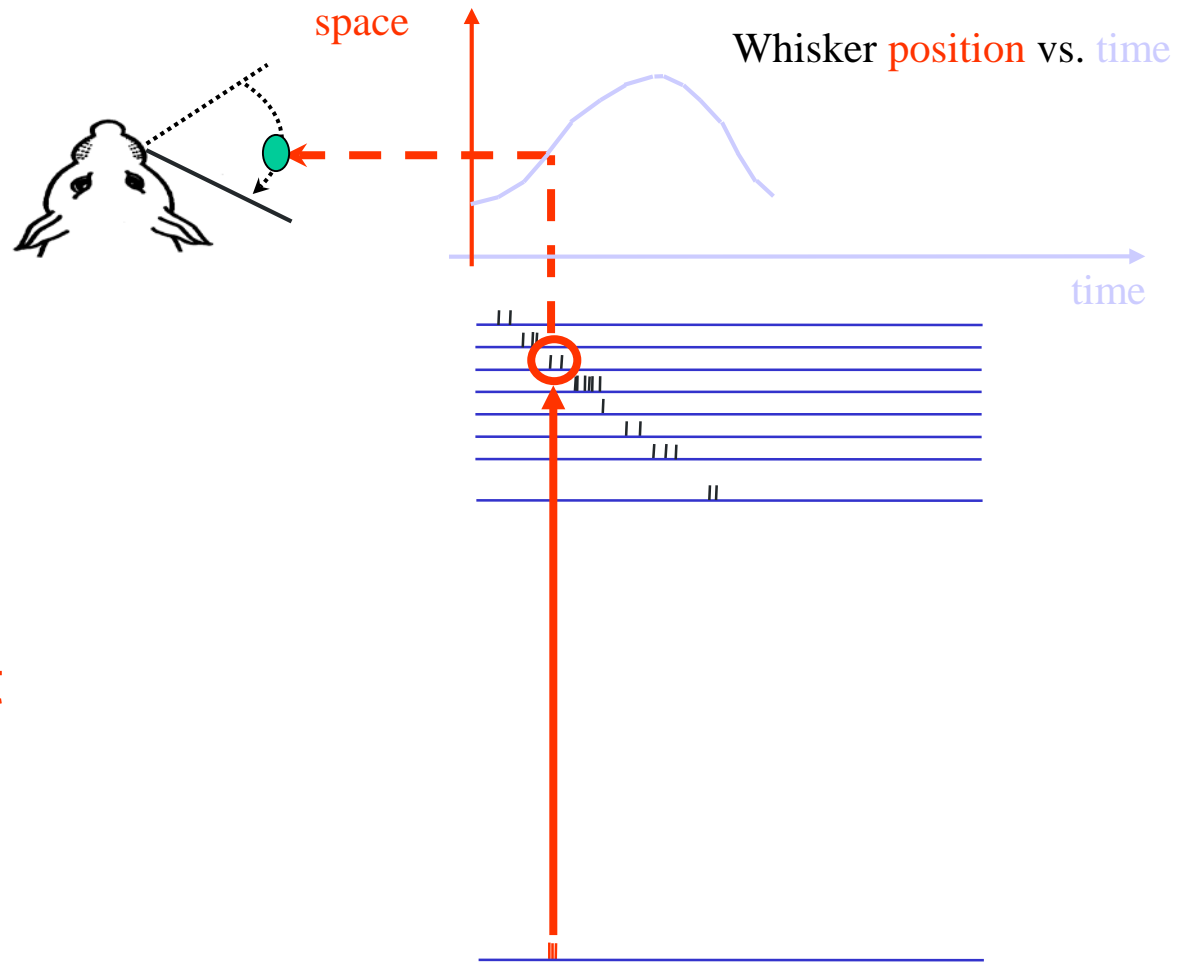

- Touch:

contact with object

# How can the brain extract the location of the object

- Whisking:

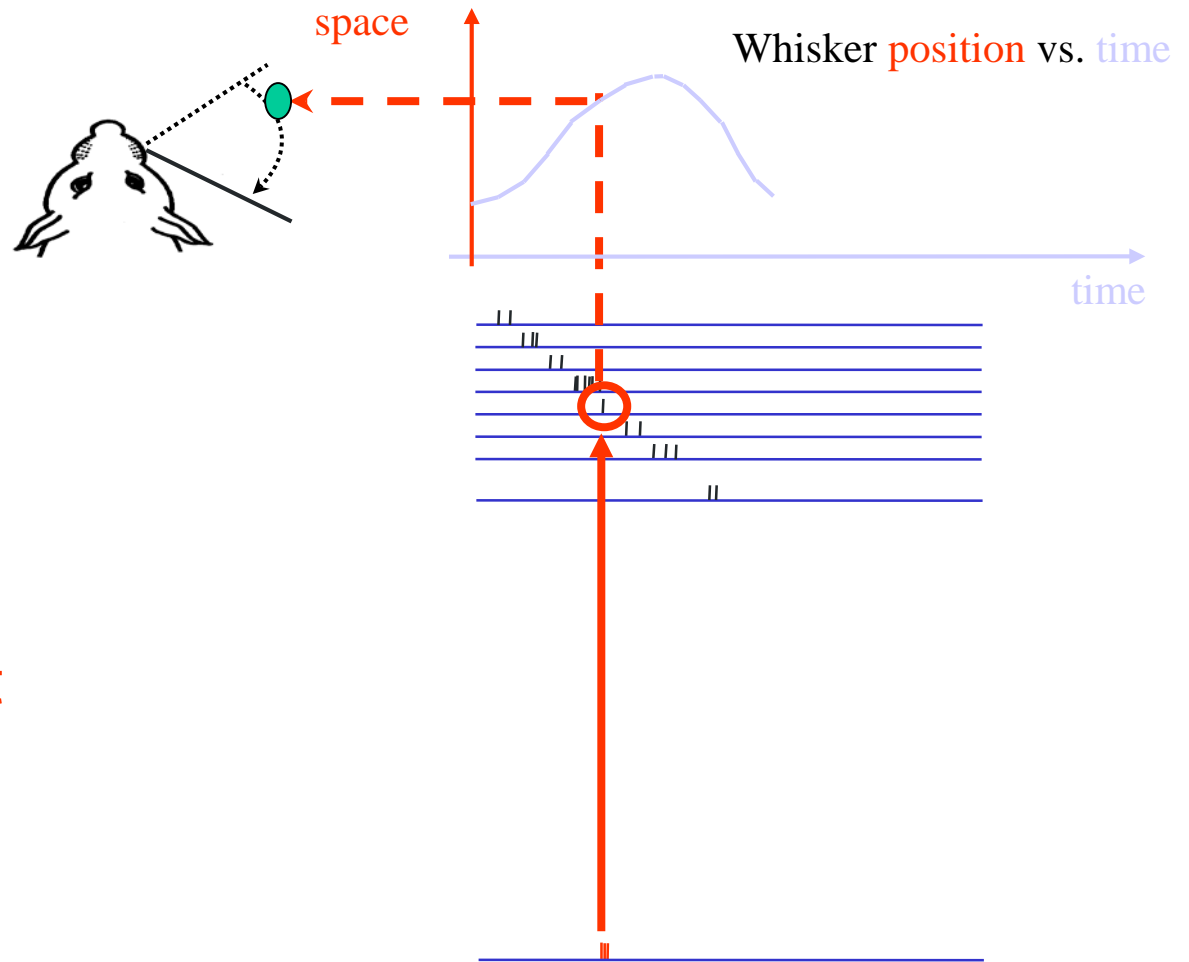

- Touch:

contact with object

sensory encoding:

What receptors tell the brain

Sensory organs consist of **receptor arrays**:

**somatosensation**

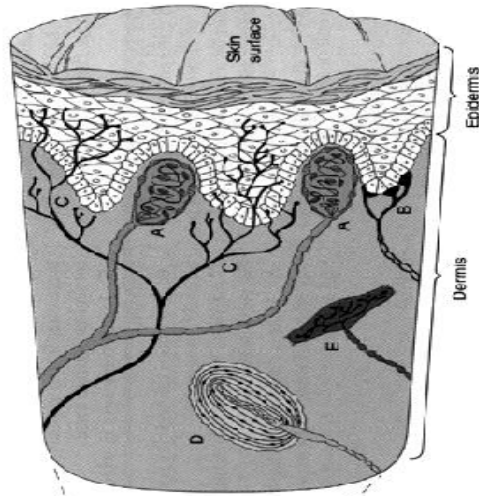

~200 μm

*Finger pad*

**audition**



10 μm

*cochlea*

**vision**

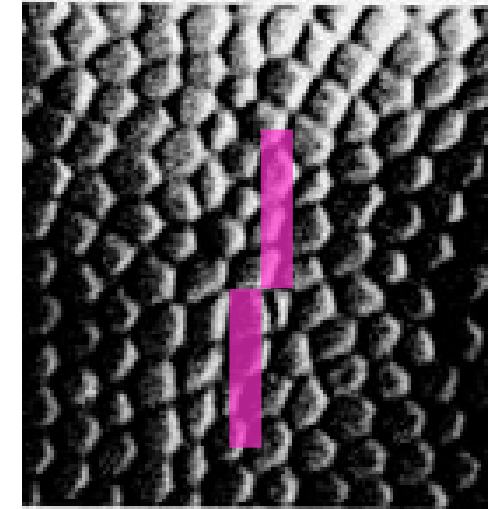

10 μm

*retina*

**Spatial organization => Spatial coding** (“*which* receptors are activated”)

**Movements => Temporal coding** (“*when* receptors are activated”)

# Orthogonal coding of object location

- **Vertical** object position is encoded by **space**
- **Horizontal** object position is encoded by **time**
- **Radial** object position is encoded by **rate**

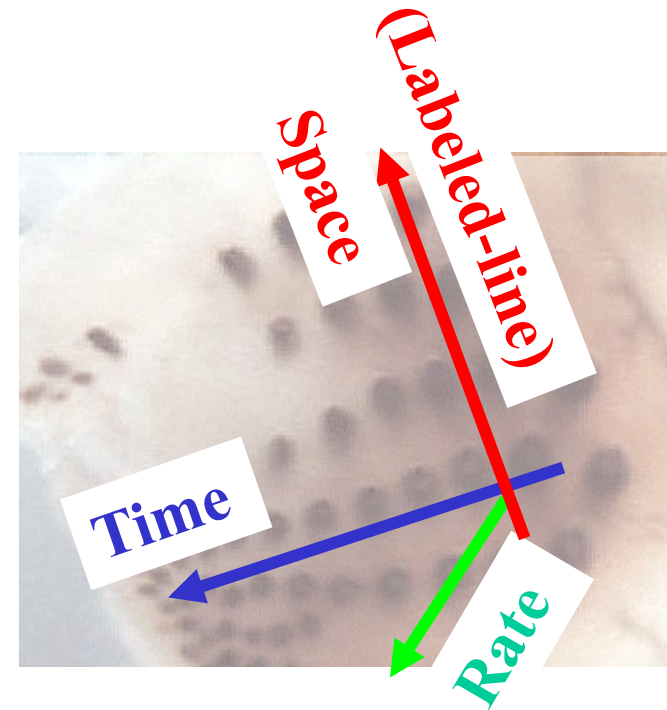

# Active sensing



**The End**